

# USER GUIDE TPWET01



## PALLET TRUCK SCALES TPWET01



Page intentionally left blank.

## Table of contents

|       |                                       |    |
|-------|---------------------------------------|----|
| 1     | INTRODUCTION .....                    | 5  |
|       | OPERATING INSTRUCTION.....            | 7  |
| 1.1.1 | Weighing.....                         | 7  |
| 1.1.2 | Controls .....                        | 8  |
| 1.1.3 | Maintenance Warnings .....            | 8  |
| 1.1.4 | Rudder assembly .....                 | 8  |
| 1.1.5 | Descending speed regulation .....     | 8  |
| 1.1.6 | Oil level .....                       | 9  |
| 1.2   | DAILY MAINTENANCE .....               | 9  |
| 1.3   | SCHEDULED MAINTENANCE.....            | 9  |
| 1.4   | REFERENCE DRAWINGS .....              | 10 |
| 2     | TECHNICAL SPECIFICATIONS.....         | 12 |
| 2.2   | POWER SUPPLY AND START UP .....       | 13 |
|       | Start up .....                        | 13 |
|       | Turning off the instrument.....       | 14 |
| 2     | INDICATOR PARTS.....                  | 15 |
|       | Display .....                         | 16 |
|       | Display Indicators .....              | 18 |
|       | Numeric input.....                    | 19 |
|       | Alphanumeric input.....               | 19 |
|       | Keyboard.....                         | 19 |
|       | Cross light .....                     | 20 |
| 3     | MAIN FUNCTIONING DESCRIPTION .....    | 21 |
|       | Zeroing.....                          | 21 |
|       | Tare.....                             | 22 |
|       | Semiautomatic tare .....              | 22 |
|       | Preset tare .....                     | 22 |
|       | Link a preset tare to an article..... | 23 |
|       | Tare cancellation .....               | 23 |
|       | Locked/unlocked tare.....             | 23 |
|       | Input texts.....                      | 24 |
|       | Databases .....                       | 25 |
|       | Insertion.....                        | 25 |

|                                                             |    |
|-------------------------------------------------------------|----|
| Modification .....                                          | 26 |
| Cancellation .....                                          | 27 |
| Selection .....                                             | 28 |
| Deselection .....                                           | 29 |
| Insertion and quick selection of the temporary element..... | 30 |
| Alphanumeric search.....                                    | 31 |
| Search by element index .....                               | 31 |
| Printouts .....                                             | 32 |
| Setpoints.....                                              | 33 |
| WEIGHING PROCEDURE .....                                    | 35 |
| Totalisation in loading .....                               | 35 |
| Totalisation in unloading .....                             | 36 |
| Totalisation in loading as well in unloading .....          | 36 |
| Totalisation with automatic execution of the tare.....      | 36 |
| Manual or automatic totalisation.....                       | 36 |
| Totalisation delay .....                                    | 37 |
| Totalisation field.....                                     | 37 |
| Error messages .....                                        | 37 |
| Conditions for totalisation.....                            | 37 |
| Progressives.....                                           | 38 |
| Additional value.....                                       | 38 |
| Progressive digits.....                                     | 38 |
| Ticket progressive.....                                     | 38 |
| Lot progressive .....                                       | 38 |

# 1 INTRODUCTION

This manual was created to help you install and learn all about the functional possibilities of the purchased indicator.

The instrument is suitable for use in various weighing environments.

Not only does it have all the normal features of high-precision scales, but it also gives you the possibility to work in specific environments due to the functioning modes contained in the software implemented in the FLASH MEMORY on the internal board. This makes the instrument extremely flexible and it can be used in many different industrial applications linked to weighing. The touch screen, the numerical and function keyboard, allow the operator an easy and immediate use and provide the microcontroller with DATA ENTRY functions in addition to the normal weighing functions. The input/output allows the instrument to control various external devices, to receive external commands, control a printer and communicate with a personal computer or to be inserted in a network of weight indicators controlled by a PC.







## WARNING

Please note that this instrument is covered by a warranty and **MUST NOT BE OPENED BY THE USER** for any reason whatsoever. Any attempt to repair or modify the unit exposes the user to the risk of electric shock and will invalidate the entire warranty.

If any problems are found in the unit or with the system in which it is used, the fact must be communicated to the manufacturer or the dealer from whom it was purchased.

In any case, **DISCONNECT THE POWER SUPPLY** before taking any action.

-  Do not pour liquids on the weight indicator.
-  Do not use solvents to clean the weight indicator.
-  Do not expose the instrument to direct sunlight nor place it near heat sources.
-  Place or anchor the weight indicator and platform on a non-vibrating base.
-  All the connections of the indicator have to be made respecting the rules applicable in the zone and in the installing environment.





Everything not expressly described in this manual has to be considered as improper use of the equipment.

**Do not install in any area where there is a risk of explosion.**



The crossed-out wheeled bin on the product means that at the product end of life, it must be taken to separate collection or to the reseller when a new equivalent type of equipment is purchased. The adequate differentiated refuse collection in having the product recycled, helps to avoid possible negative effects on the environment and health and supports the recycling of the materials of which the equipment is made. The unlawful disposal of the product by the user will entail fines foreseen by the current regulations.

Used symbols through the manual

|                                                                                     |                                                                                                                  |
|-------------------------------------------------------------------------------------|------------------------------------------------------------------------------------------------------------------|
|    | ATTENTION!<br>Only qualified personnel must perform this operation                                               |
|    | ATTENTION!<br>This is referred to working with live wires: only qualified personnel must perform this operation. |
|    | CE CONFORMITY                                                                                                    |
|   | IDENTIFIES THE CLASS OF PRECISION.                                                                               |
|  | It identifies an advanced function explained in the technical manual (for technical personnel).                  |

This pallet truck scale has been designed to only weigh on pallets.

Never exceed maximum load, see the weight indicator's label.

Do not use in an environment with any risk of explosion.

Load only when forks are in the lowest position.

Check that the pallet truck scale is in good operating conditions.

To get the best weighing results, lift up the forks about 5-10 cm.

Do not expose the weighting indicator to atmospheric agents ( rain, sun, etc. ).

All the connections of the indicator have to be made respecting the rules applicable in the zone and in the installing environment.

Read and understand all instructions.

In case of approved scale, the weighing has to be done on a EUR-EPAL 800x1200mm pallet (ref. Norms UIC 435-2 and UIC 435-4).

**FIX THE LOAD ON THE PALLET, AS SHOWN IN THE DRAWING.**

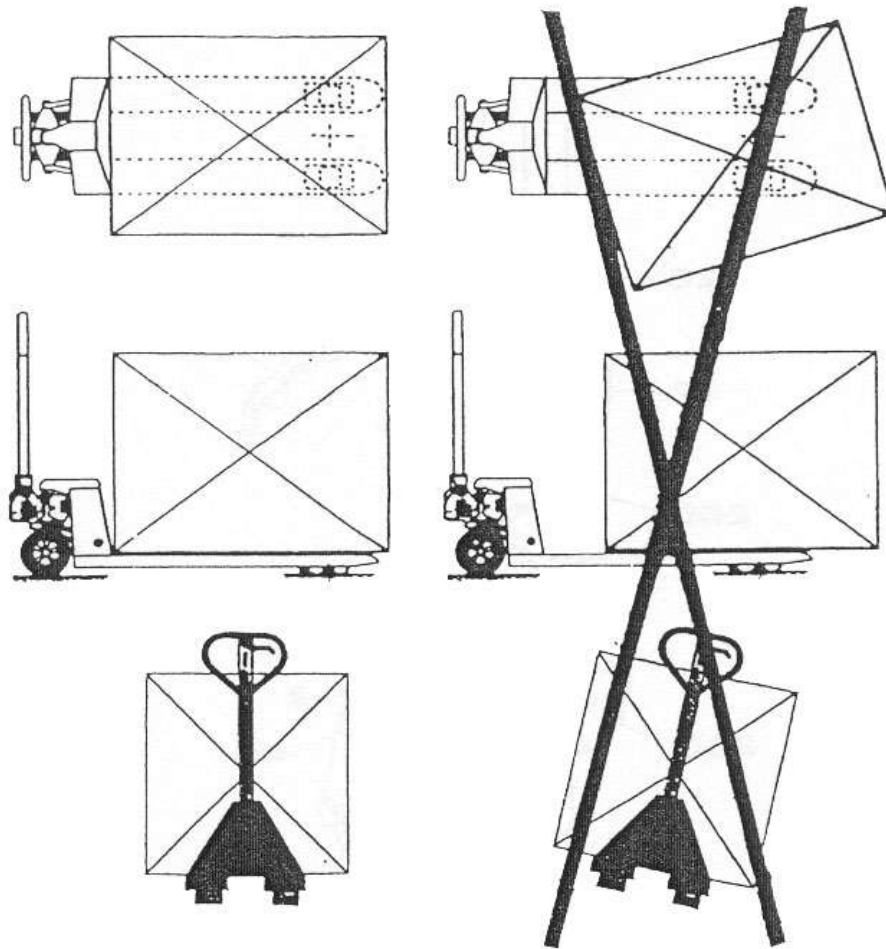

**THE PARTS OF THE INSTRUMENT CONTAINING DANGEROUS ELECTRICAL TENSION ARE ISOLATED AND INACCESSIBLE TO THE USER UNLESS IT HAS BEEN DAMAGED, OPENED, OR ALTERED.**

## OPERATING INSTRUCTION

A pallet truck scale is an electronic weighing system directly installed on a pallet truck; it must be used on even solid surfaces and driven always in the normal position. Before loading, check the maximum load allowed by the pallet truck scale in use (refer to instruction plate on the side of the pallet truck).

The rudder has a double function, direction control and hydraulic lifting.

**N.B.** Lift up or pull down only when the pallet truck scale is in a standing still position.

### 1.1.1 Weighing

In order to obtain correct weighing results, one is required to use the pallet truck scale on a flat surface, lift up the forks about 5-10 cm (see the following "CONTROLS" chapter) and wait for the stability before the weight reading.

### 1.1.2 Controls

The lever on the right side of the rudder can be put in 3 positions, like it shows on the plate “Y” in figure B.

- POS. 1 – centre = **TRANSPORT** The rudder is completely free to allow driving control.
- POS. 2 – down = **LIFT UP** By moving the lever downward the lifting mechanism is activated. Pushing down the rudder will cause the load to lift up.
- POS. 3 – up = **PULL DOWN** By moving the lever upward the load will descend. When the lever is quickly moved upward, a special valve controls the descending speed of the load.

### 1.1.3 Maintenance Warnings

Before you perform any service, make sure the pallet truck is in a condition of safety.

Never discharge any residue without taking the necessary environmental precautions.

Only perform the service described in this manual. Maintenance and repair jobs not included in this manual must be performed by authorised personnel only.

Serious injury could result from service or maintenance performed by unqualified personnel.

- Never alter the safety level of the machine. Always use identical replacement parts.
- Never remove or hide in anyway instruction plates and stickers.
- Do not modify the pallet truck.
- Do not use inflammable cleaners. Do not use direct jets of water. Do not pour liquids on the indicator.

### 1.1.4 Rudder assembly

1. Lock rudder ( 228 ) to hydraulic pump ( 200 ) with screws ( 27 ) that you can find in the box.
2. Lock chain ( 208 ) to lift down pedal ( 50 ). Rotate pedal to simplify the connection.

### 1.1.5 Descending speed regulation

1. Lift up forks to maximum height.
2. Set right lever to POS. 1 ( centre ).
3. Make sure the rudder ( 200 ) is in a vertical position.
4. Unscrew bolt ( 2 ) and turn clockwise the adjustable screw ( 48 ) until the forks start to descend.
5. Turn adjustable screw 1 ½ turn counter clockwise, then screw bolt ( 2 ).
6. You should be able to obtain a descending movement from every position of the rudder.



### 1.1.6 Oil level

Check oil level every 6 months. Only use hydraulic oil. No engine oil or brake oil.

Oil viscosity 30 Cst at 40°C . Quantity 0.3 lt.

With the fork in the lower position follow these steps:

1. Remove cover ( 204 ), o-ring ( 11 ) and cap ( 202 ).
2. If necessary add oil. Maximum filling level is 200mm below top of tank.
3. Turn on the pump to get air out of the hydraulic circuit.
4. Put cap ( 202 ), o-ring ( 11 ) and cover (204 ) back.

## 1.2 DAILY MAINTENANCE

To keep the pallet truck scale in good operating condition, the operator must perform daily these checkpoints:

- Check overall conditions.
- Check weighing scale.
- Check printer ( if installed ).
- Check pump.
- Check rollers and wheels.

## 1.3 SCHEDULED MAINTENANCE

Maintenance performed by qualified personnel only. Make sure to put the pallet truck scale on a flat and solid surface.

- Check that nothing is blocking the rollers.
- Grease rollers and wheels bearings.
- Grease control lever on rudder.
- Check oil every six months. Fill up if necessary with IP46 hydraulic oil.

**N.B.** If oil needs to be replaced, follow the necessary precaution and law requirements for the disposal of the exhausted oil.



Replace rollers and wheels when necessary. For any questions or problems check with an Authorised service Centre.

1.4 REFERENCE DRAWINGS

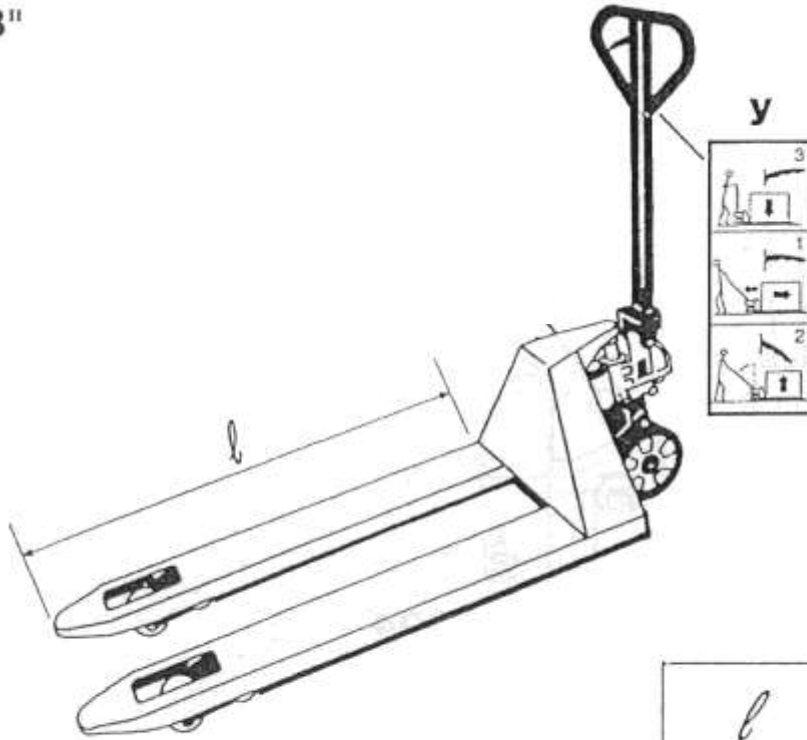
B''



D''

|                                                                                      |      |
|--------------------------------------------------------------------------------------|------|
|  | 1150 |
|  | 120  |

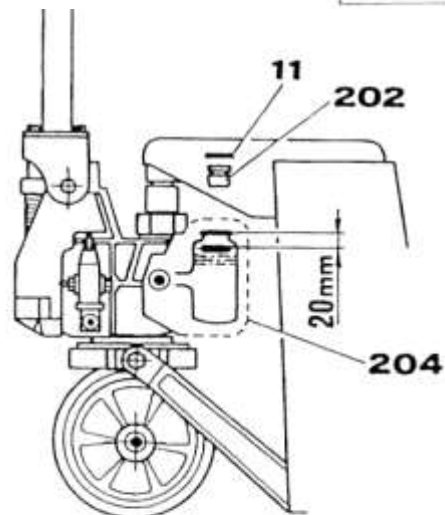

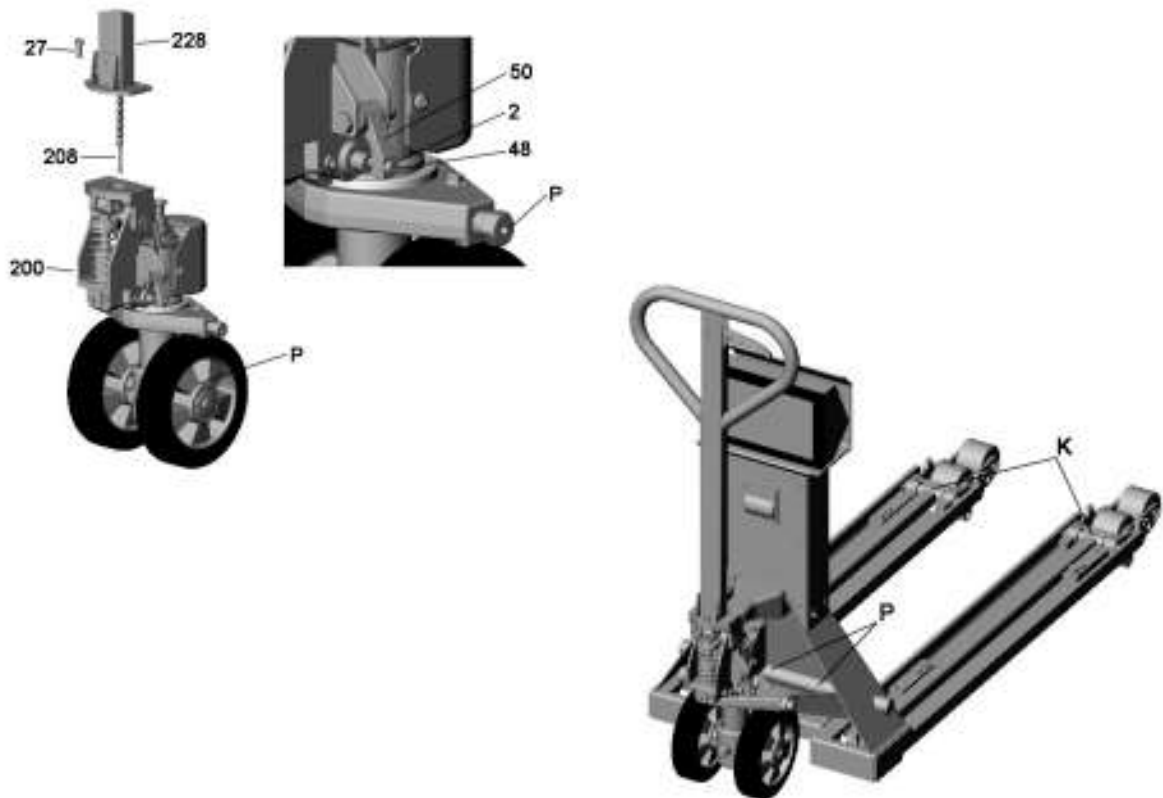

**LUBRIFICATION POINTS**

Ref. "K" fig. D needs silicon oil for food industry, expiry of 1 month.

Ref. "P" fig. D needs silicon grease for food industry, expiry of 2 months.

## 2 TECHNICAL SPECIFICATIONS

|                                             |                                                                                                                                                                                                                                                                                                                                                                                                  |
|---------------------------------------------|--------------------------------------------------------------------------------------------------------------------------------------------------------------------------------------------------------------------------------------------------------------------------------------------------------------------------------------------------------------------------------------------------|
| POWER SUPPLY                                | 12 Vdc ( 8 ÷ 24 Vdc in the IO versions), with internal 100 ÷ 240 Vac (50÷60 Hz) / 12 Vdc adapter.                                                                                                                                                                                                                                                                                                |
| MAXIMUM POWER                               | 16 VA.                                                                                                                                                                                                                                                                                                                                                                                           |
| OPERATING TEMPERATURE                       | From -10 to +40 °C.                                                                                                                                                                                                                                                                                                                                                                              |
| CONVERTER                                   | 24 bit Sigma Delta.                                                                                                                                                                                                                                                                                                                                                                              |
| CONVERSION SPEED                            | 200 conv./sec with automatic selection.                                                                                                                                                                                                                                                                                                                                                          |
| RANGE OF INPUT SIGNAL                       | 0.6 mV/V – 3.2 mV/V.                                                                                                                                                                                                                                                                                                                                                                             |
| MINIMUM VOLTAGE PER DIVISION                | 0.3 µV (approved instrument); 0.03 µV (non-approved instrument).                                                                                                                                                                                                                                                                                                                                 |
| AUTOMATIC ZERO DETECTION                    | Only in gross mode, programmable at +/- ¼, ½, 1, 2 divisions.                                                                                                                                                                                                                                                                                                                                    |
| ZERO RANGE                                  | Configurable up to +/- 50% of max load capacity.                                                                                                                                                                                                                                                                                                                                                 |
| AUTO ZERO AT START-UP                       | Configurable up to +/- 50% of max load capacity.                                                                                                                                                                                                                                                                                                                                                 |
| LOAD CELL POWER SUPPLY                      | 5Vdc ± 5%, 120mA (max 8 350Ω cells).                                                                                                                                                                                                                                                                                                                                                             |
| LOAD CELL CONNECTIONS                       | 6 wires with Remote Sense.                                                                                                                                                                                                                                                                                                                                                                       |
| DISPLAY DIVISIONS                           | 10000e, 3 x 3000e for legal for trade weighing, expandable up to 800.000 for internal use (with <b>minimum</b> signal coming from the 1.6 mV/V cell).                                                                                                                                                                                                                                            |
| DISPLAYS                                    | Graphic touch screen 320x240 dots (black & white).                                                                                                                                                                                                                                                                                                                                               |
| DATABASE/MEMORY                             | Articles database of 1000 items (3 descriptions of 25 characters each, linked tare, linked customer, 3 setpoints)<br>Customers database of 200 items (5 descriptions of 30 characters each)<br>Tare database (300 items for every scale)                                                                                                                                                         |
| SIGNALS                                     | 3-way control light                                                                                                                                                                                                                                                                                                                                                                              |
| KEYBOARD                                    | Impermeable polycarbonate keyboard (IP65 protection degree), with membrane keys with audible and tactile feedback.                                                                                                                                                                                                                                                                               |
| PARAMETER SETUP                             | Calibration and linearity (up to 8 points), fully digital and programmable from the keyboard or from PC with Dinitools™.                                                                                                                                                                                                                                                                         |
| CLOCK/DATE                                  | Fitted, with buffer RAM.                                                                                                                                                                                                                                                                                                                                                                         |
| SERIAL OUTPUTS                              | - 2 input/output RS232 ports on terminal board/ amp connector.<br>- 1 input/output RS485 port on terminal board or RS232 on amp connector.                                                                                                                                                                                                                                                       |
| INPUTS AND OUTPUTS                          | - Management of PC keyboard or barcode reader<br>- 2 optoisolated inputs (optoisolated photo couplers), 12Vdc – 24Vdc, 20mA max<br>- 4 outputs (optoisolated photomofets), 48Vac / 0.15A, 60Vdc / 0.15A, 10Ω max.<br>With IO expansion:<br>- 8 inputs (optoisolated photo couplers), 12Vdc – 24Vdc, 20mA max.<br>- 16 outputs (optoisolated photomofets), 48Vac / 0.15A, 60Vdc / 0.15A, 10Ω max. |
| ANALOG OUTPUT (with analog expansion board) | - 16-bit analogue output configurable from keyboard (full-scale value; zero scale value and minimum value) from 0 to 10 Vdc or from 0 to 20mA; the maximum resistance applicable on the output current is 350 Ω and the minimum resistance applicable on the output voltage is 10 kΩ.                                                                                                            |

## 2.1 POWER SUPPLY AND START UP

The instruments are powered with a 6Vdc rechargeable internal battery.

It is possible to charge the battery through the 12V power adapter which should be connected to the 230 Vac mains voltage.

Safety norms must be respected for the connection to the mains voltage including the use of a line which has to be free from noise generated by other electronic equipment.





### BATTERY CHARACTERISTICS



Material: LEAD  
 Power: 4,5 Ah or 10 Ah  
 Output: 6 V

**THE BATTERY MUST ONLY BE REPLACED WITH AN ORIGINAL FROM THE MANUFACTURER.**

In order **TO CHARGE THE BATTERY** through the 230Vac mains, one should insert the plug end of the AC/DC power adapter into the socket on the column, and the power adapter to your 230Vac current source.

## 2.2 Start up

| Step | Description                                                                                                                                                                                                                                                                                                            | Screen                                                                               |
|------|------------------------------------------------------------------------------------------------------------------------------------------------------------------------------------------------------------------------------------------------------------------------------------------------------------------------|--------------------------------------------------------------------------------------|
| 1    | Press the  key until the instrument powers on                                                                                                                                                                                       |  |
| 2    | The logo (  Logo to show at the start up) and the software version appear for some instants.<br>EGT-AF01-XX is the name of the installed software, in which XX identifies the language.<br>XX.YY is the installed software version. |  |

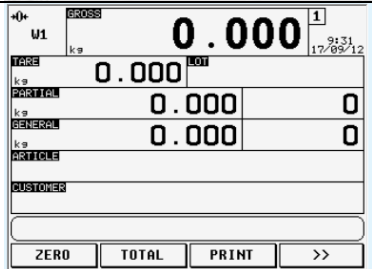
|          |                                                                                                                                                                                                     |                                                                                    |
|----------|-----------------------------------------------------------------------------------------------------------------------------------------------------------------------------------------------------|------------------------------------------------------------------------------------|
| <p>3</p> | <p>The zeroing procedure clears the weight on the scale within the tolerance (  Automatic zeroing at start up)</p> |  |
| <p>4</p> | <p>The main screen appears on the display</p>                                                                                                                                                       |  |

### 2.3 Turning off the instrument

To turn off the indicator press the  key until the logo appears on the display.

# 3 INDICATOR PARTS



Figure 1. Front panel

| Part | Description            |
|------|------------------------|
| 1    | Touch screen           |
| 2    | Cross light (3 colors) |
| 3    | Keyboard               |

### 3.1 Display

The indicator presents 2 main screens, illustrated in the below scheme:

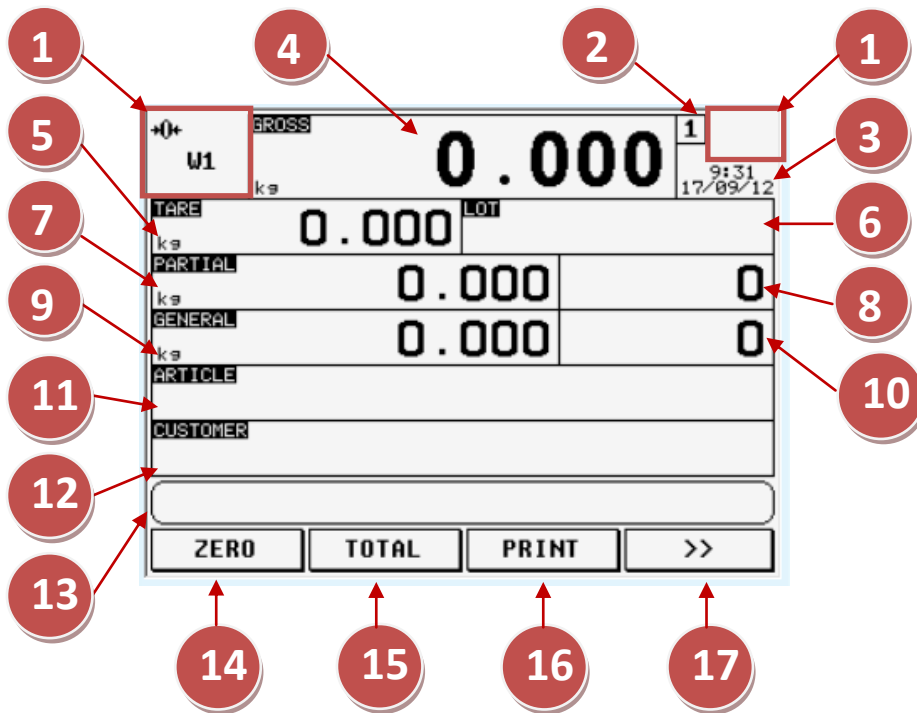

Figure 2. First main screen

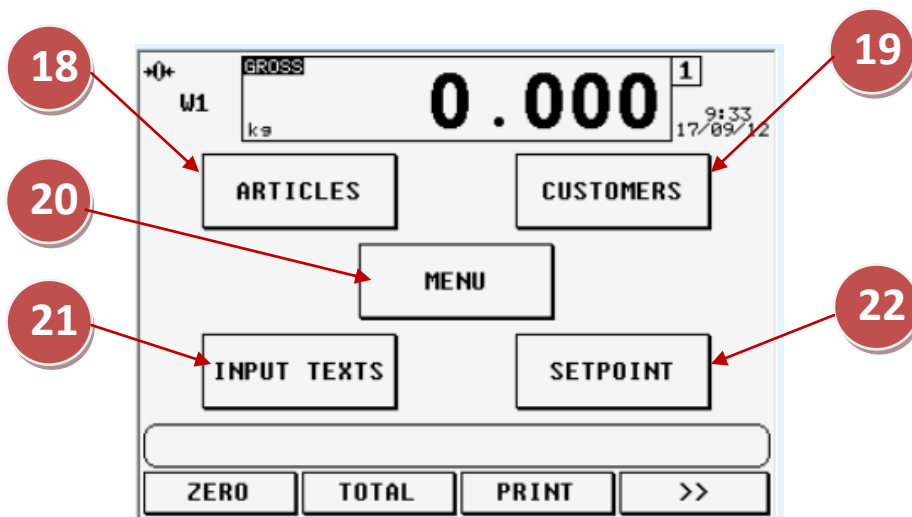







Figure 3. Second main screen



## INDICATOR PARTS

| Element | Description                                                                                          |
|---------|------------------------------------------------------------------------------------------------------|
| 1       | Display indicators                                                                                   |
| 2       | Active scale<br>Touch to switch to the next scale                                                    |
| 3       | Time and date<br>Touch to change the date                                                            |
| 4       | Weight value on the active scale<br>Touch to tare the gross weight                                   |
| 5       | Tare value<br>Touch to insert a preset tare                                                          |
| 6       | Description of the first input text (LOT)<br>Touch to change the description of the first input text |
| 7       | Net value of the partial total<br>Touch to print and reset the partial total                         |
| 8       | Number of weighs of the partial total<br>Touch to print and reset the partial total                  |
| 9       | Net value of the general total<br>Touch to print and reset the general total                         |
| 10      | Number of weighs of the general total<br>Touch to print and reset the general total                  |
| 11      | Selected article<br>Touch to select an article                                                       |
| 12      | Selected customer<br>Touch to select a customer                                                      |
| 13      | System messages area                                                                                 |
| 14      | Touch to zero the scale                                                                              |
| 15      | Touch to total                                                                                       |
| 16      | Touch to print                                                                                       |
| 17      | Touch to switch to the next screen                                                                   |
| 18      | Touch to manage the articles database                                                                |
| 19      | Touch to manage the customers database                                                               |
| 20      | Touch to access to the indicator functions                                                           |
| 21      | Touch to manage the input texts                                                                      |
| 22      | Touch to manage the setpoints                                                                        |

## 3.1.1 Display Indicators

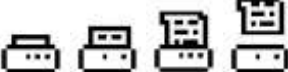
| Symbol                                                                            | Description                                                                                                                          |
|-----------------------------------------------------------------------------------|--------------------------------------------------------------------------------------------------------------------------------------|
|  | The weight detected by the weighing system is near the zero, included within the interval of $-1/4$ and $+1/4$ of the scale division |
|  | The weight is unstable                                                                                                               |
|  | A tare value has been acquired                                                                                                       |
|  | A preset tare value has been entered                                                                                                 |
|  | Active weighing range                                                                                                                |
|  | Locked keyboard                                                                                                                      |
|  | Transmission of the data to the printer serial port underway                                                                         |





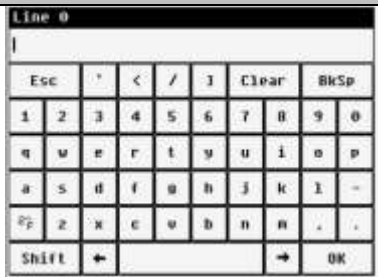

### 3.1.2 Numeric input

| Screen                                                                            | Function                                                                                                                                                                                                                                                                                                                                                                                                            |
|-----------------------------------------------------------------------------------|---------------------------------------------------------------------------------------------------------------------------------------------------------------------------------------------------------------------------------------------------------------------------------------------------------------------------------------------------------------------------------------------------------------------|
|  | <p>Allows to insert a numeric value within the range.<br/> <b>X ~ Y</b>: valid range for the value to insert<br/> <b>0...9</b>: numbers<br/> <b>.</b>: decimal point<br/> <b>+/-</b>: positive or negative sign<br/> <b>/ * - +</b>: arithmetic operations<br/> <b>C</b>: clears all the value<br/> <b>BkSp</b>: backspace<br/> <b>OK</b>: exit saving the value<br/> <b>Esc</b>: exit without saving the value</p> |

### 3.1.3 Alphanumeric input

| Screen                                                                             | Function                                                                                                                                                                                                                                                                                                                                                                                                                                             |
|------------------------------------------------------------------------------------|------------------------------------------------------------------------------------------------------------------------------------------------------------------------------------------------------------------------------------------------------------------------------------------------------------------------------------------------------------------------------------------------------------------------------------------------------|
|  | <p>Allows to insert an alphanumeric text.<br/> <b>← →</b>: scroll left or right<br/> <b>Clear</b>: clears all the text<br/> <b>Bksp</b>: backspace<br/> <b>2^F</b>: switches to special characters<br/> <b>Shift</b>: changes the character case and switches between letter and number modes<br/> <b>OK</b>: exit saving the text<br/> <b>Esc</b>: exit without saving the text</p> <p>NOTE: on the first pressed key all the field is replaced</p> |

## 3.2 Keyboard

| Key                                                                                                                                                                         | Function                                                                        |
|-----------------------------------------------------------------------------------------------------------------------------------------------------------------------------|---------------------------------------------------------------------------------|
|                                                                                          | Press to clear the tare<br>Press for a long time to power on/off the instrument |
|                                                                                          | Press to tare the gross weight                                                  |
|                                                                                          | Press to switch to the next scale                                               |
|                                                                                          | Press to zero the scale                                                         |
|                                                                                          | Press to switch to the next screen                                              |
|  ...  | Press to insert the preset tare                                                 |

### 3.3 Cross light

The standard functioning in the weighing environment is described in the table:

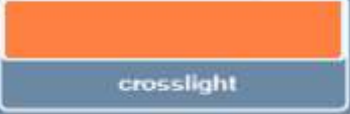
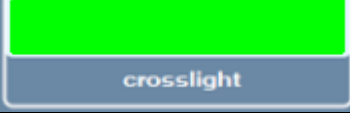
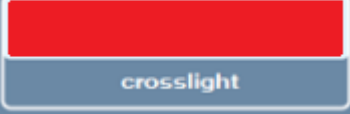

| Step | Description                                                                                          | Light                                                                               |
|------|------------------------------------------------------------------------------------------------------|-------------------------------------------------------------------------------------|
| 1    | The net weight is below setpoint 1 or is unstable (cross light turned off)                           |  |
| 2    | The net weight is greater or equal setpoint 1 (see section 0) and is stable (yellow light turned on) |  |
| 3    | The net weight is greater or equal setpoint 2 (see section 0) and is stable (green light turned on)  |  |
| 4    | The net weight is greater or equal setpoint 3 (see section 0) and is stable (red light turned on)    |  |

# 4 MAIN FUNCTIONING DESCRIPTION

All the functions of the indicator are available from the  button in the second screen. The functions are divided into the following groups:

| Group             | Description                                                          |
|-------------------|----------------------------------------------------------------------|
| Scale functions   | Operations to the weight (zeroing, tare, ...)                        |
| Printout          | Print functions management                                           |
| Generic functions | Generic operations to the indicator (lock keyboard, calculator, ...) |
| Diagnostic        | Functions to check the peripheral units working state                |
| Input texts       | Input texts management                                               |
| Databases         | Databases management                                                 |
| AF01 functions    | Total operations                                                     |
| Totals            | Print and reset of the totals                                        |
| Progressives      | Weigh progressives management                                        |

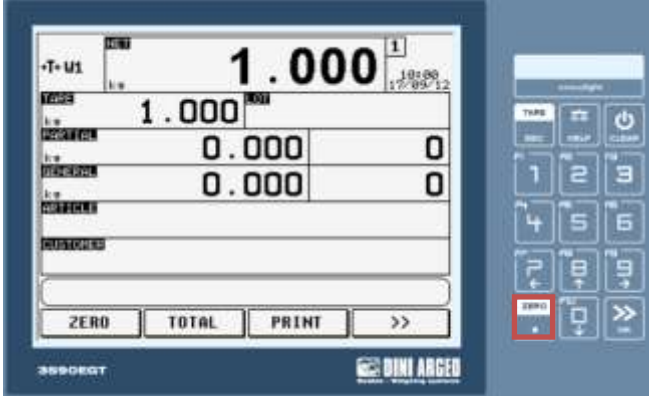
## 4.1 Zeroing

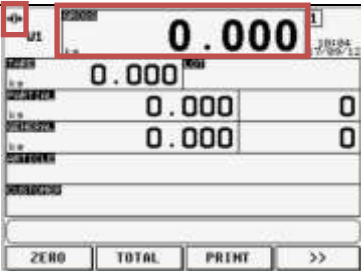

| Step | Description                                                                                       | Screen                                                                               |
|------|---------------------------------------------------------------------------------------------------|--------------------------------------------------------------------------------------|
| 1    | Press the  key |  |
| 2    | A message appears on the display during the zeroing                                               |  |

## MAIN FUNCTIONING DESCRIPTION

|   |                                                                                                                                                                                                                                                                      |                                                                                    |
|---|----------------------------------------------------------------------------------------------------------------------------------------------------------------------------------------------------------------------------------------------------------------------|------------------------------------------------------------------------------------|
| 3 | <p>If the weight on the scale is included in the percentage (  Zeroing percentage with ZERO key), it is zeroed and the <math>\rightarrow 0 \leftarrow</math> indicator turns on</p> |  |
|---|----------------------------------------------------------------------------------------------------------------------------------------------------------------------------------------------------------------------------------------------------------------------|------------------------------------------------------------------------------------|

### 4.2 Tare

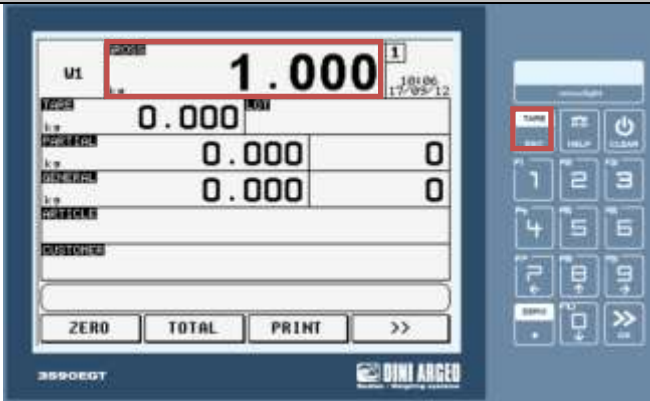
#### 4.2.1 Semiautomatic tare

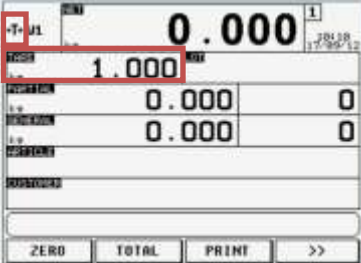
| Step | Description                                                                                                                                                                                                        | Screen                                                                               |
|------|--------------------------------------------------------------------------------------------------------------------------------------------------------------------------------------------------------------------|--------------------------------------------------------------------------------------|
| 1    | <p>Press the  key or touch on the weight area to tare the gross weight on the scale</p>                                           |   |
| 2    | A message appears on the display                                                                                                                                                                                   |  |
| 3    | <p>If the weight is almost one division and is stable and valid (not in the underload/overload condition), the gross weight is stored as tare and the <math>\rightarrow T \leftarrow</math> indicator turns on</p> |  |

#### 4.2.2 Preset tare

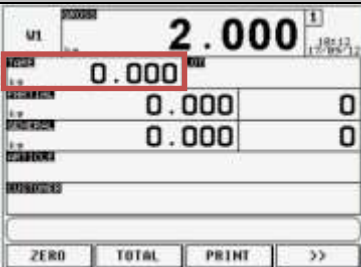
| Step | Description            | Screen                                                                               |
|------|------------------------|--------------------------------------------------------------------------------------|
| 1    | Touch on the tare area |  |

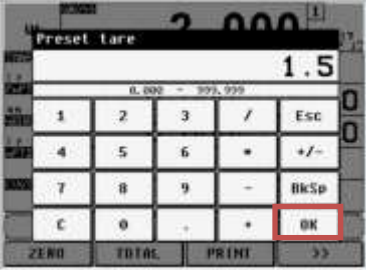
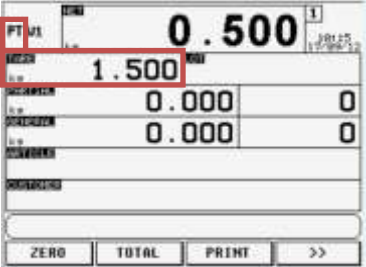

|   |                                                                                            |                                                                                    |
|---|--------------------------------------------------------------------------------------------|------------------------------------------------------------------------------------|
| 2 | Insert the preset tare value and confirm with the <b>OK</b> key                            |  |
| 3 | The entered value is subtracted from the gross weight and the <b>PT</b> indicator turns on |  |

#### 4.2.3 Link a preset tare to an article

It's possible to insert the tare value of an article in the database. By selecting the article the preset tare is activated.

#### 4.2.4 Tare cancellation

It's possible to cancel the stored tare value in the following ways:

- By touching the weight area or by pressing the  when the platform is unloaded
- By setting the preset tare value to 0
- By pressing the  key

#### 4.2.5 Locked/unlocked tare

Normally the tare is active until the cancellation operation (locked tare). One can also choose that the tare value is cancelled automatically when the scale is unloaded (unlocked tare) through Menu → Scale functions → **Lock/Unlock tare** function.

### 4.3 Input texts

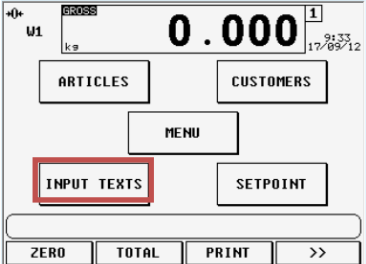
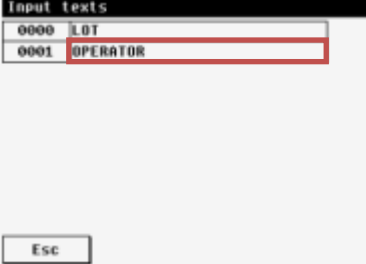
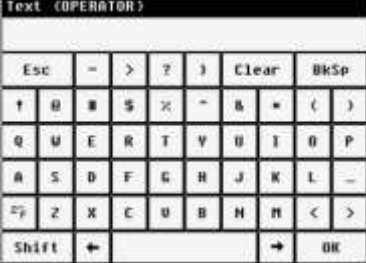
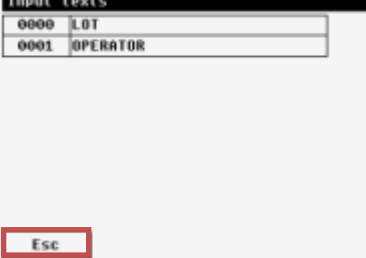
| Step | Description                                                          | Screen                                                                                                                                                                                                                                                                                                                                                                    |
|------|----------------------------------------------------------------------|---------------------------------------------------------------------------------------------------------------------------------------------------------------------------------------------------------------------------------------------------------------------------------------------------------------------------------------------------------------------------|
| 1    | Touch on the button to get access to the input texts                 |  <p>The screenshot shows a main menu with several buttons: ARTICLES, CUSTOMERS, MENU, INPUT TEXTS (highlighted with a red box), and SETPOINT. At the top, there is a display showing '0.000' and '17/09/12'. At the bottom, there are buttons for ZERO, TOTAL, PRINT, and &gt;&gt;.</p> |
| 2    | Touch on the desired text to be changed                              |  <p>The screenshot shows the 'Input texts' screen with two entries: '0000 LOT' and '0001 OPERATOR'. The 'OPERATOR' text field is highlighted with a red box. An 'Esc' button is visible at the bottom.</p>                                                                              |
| 3    | Insert the content of the text and confirm with the <b>OK</b> button |  <p>The screenshot shows a virtual keyboard on the 'Text (OPERATOR)' screen. The keyboard has a grid of letters and symbols, with 'Esc' and 'OK' buttons. The 'Esc' button is highlighted with a red box.</p>                                                                          |
| 4    | Touch on the <b>ESC</b> button to go back to the main screen         |  <p>The screenshot shows the 'Input texts' screen with two entries: '0000 LOT' and '0001 OPERATOR'. The 'Esc' button at the bottom is highlighted with a red box.</p>                                                                                                                 |



## 4.4 Databases



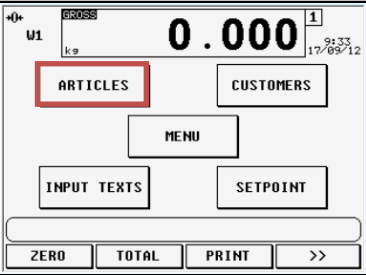
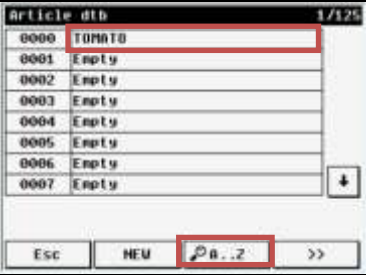
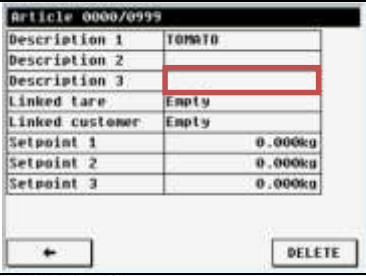
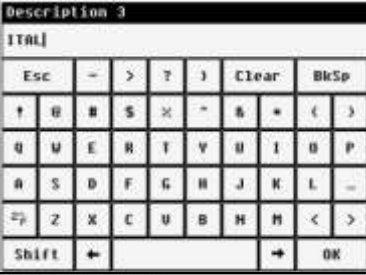
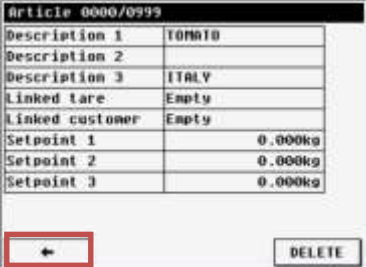

### 4.4.1 Insertion

| Step | Description                                                                                                                               | Screen                                                                                                                                                                                                                                                                                                           |
|------|-------------------------------------------------------------------------------------------------------------------------------------------|------------------------------------------------------------------------------------------------------------------------------------------------------------------------------------------------------------------------------------------------------------------------------------------------------------------|
| 1    | Touch on the button to get access to the desired database                                                                                 | <p>The screenshot shows a main menu with a large '0.000' display at the top. Below the display are several buttons: 'ARTICLES' (highlighted with a red box), 'CUSTOMERS', 'MENU', 'INPUT TEXTS', and 'SETPOINT'. At the bottom, there are buttons for 'ZERO', 'TOTAL', 'PRINT', and '&gt;&gt;'.</p>              |
| 2    | Select the desired position by touching the element or by touching the <b>NEW</b> button to insert an element in the first empty position | <p>The screenshot shows a table titled 'Article dtb' with 12 columns and 8 rows. The first row is highlighted. Below the table is a 'NEW' button highlighted with a red box, along with 'Esc', 'A..Z', and '&gt;&gt;' buttons.</p>                                                                               |
| 3    | Touch the first field to insert the content                                                                                               | <p>The screenshot shows an edit form for 'Article 0000/0999'. It has fields for 'Description 1', 'Description 2', 'Description 3', 'Linked tare', 'Linked customer', and three 'Setpoint' fields. The first 'Description 1' field is highlighted with a red box. At the bottom are '←' and 'DELETE' buttons.</p> |
| 4    | Insert the content of the field and confirm it with the <b>OK</b> button                                                                  | <p>The screenshot shows a numeric keypad with various symbols and numbers. The 'OK' button at the bottom right is highlighted with a red box.</p>                                                                                                                                                                |
| 5    | Repeat the operation for the desired fields and press the <b>←</b> button to confirm or the <b>DELETE</b> button to cancel                | <p>The screenshot shows the same edit form as in step 3, but now 'TOMATO' is entered in the 'Description 1' field. The left arrow button '←' at the bottom is highlighted with a red box.</p>                                                                                                                    |
| 6    | The inserted element appears in the table with the first field value                                                                      | <p>The screenshot shows the 'Article dtb' table again. The first row now contains '0000' in the first column and 'TOMATO' in the second column. The first row is highlighted with a red box.</p>                                                                                                                 |

4.4.2 Modification

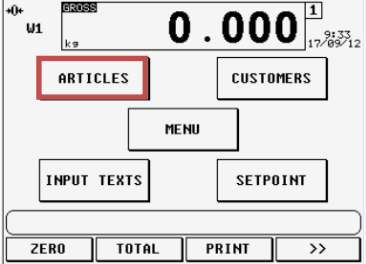
| Step | Description                                                                                 | Screen                                                                               |
|------|---------------------------------------------------------------------------------------------|--------------------------------------------------------------------------------------|
| 1    | Touch the button to get access to the desired database                                      |    |
| 2    | Touch the element or the <b>A..Z</b> button to search the element to be updated             |    |
| 3    | Touch the desired field to be modified                                                      |   |
| 4    | Insert the content of the field and confirm it with the <b>OK</b> button                    |  |
| 5    | Repeat the operation for the desired fields to be updated and press the ← button to confirm |  |

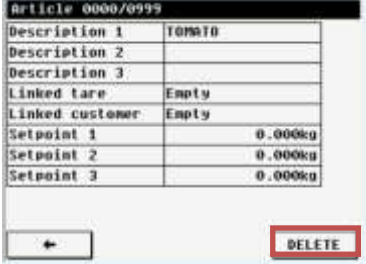
4.4.3 Cancellation



| Step | Description                                                                     | Screen                                                                                                                                                                                                                                                                                                                                                               |
|------|---------------------------------------------------------------------------------|----------------------------------------------------------------------------------------------------------------------------------------------------------------------------------------------------------------------------------------------------------------------------------------------------------------------------------------------------------------------|
| 1    | Touch the button to get access to the desired database                          |  <p>The screenshot shows a main menu with a 'GROSS' display of '0.000' and a date '17/09/12'. Several menu items are visible: 'ARTICLES', 'CUSTOMERS', 'MENU', 'INPUT TEXTS', and 'SETPOINT'. The 'ARTICLES' button is highlighted with a red rectangular box.</p>                 |
| 2    | Touch the element or the <b>A..Z</b> button to search the element to be deleted |  <p>The screenshot shows a list titled 'Article dtb' with 1/125 items. The first item, '0000 TOMATO', is highlighted with a red rectangular box. Other items are '0001 Empty' through '0007 Empty'. At the bottom, there are buttons for 'Esc', 'NEU', 'A..Z', and '&gt;&gt;'.</p> |
| 3    | Touch the <b>DELETE</b> button                                                  |  <p>The screenshot shows the details for 'Article 0000/0999'. It lists 'Description 1 TOMATO' and other fields like 'Linked tare', 'Linked customer', and 'Setpoint 1-3'. The 'DELETE' button at the bottom right is highlighted with a red rectangular box.</p>                  |
| 4    | Press the button to confirm or not the cancellation                             |  <p>The screenshot shows a confirmation dialog box with the text 'Delete the record?'. It has two buttons: 'No' and 'Yes'. The 'Yes' button is highlighted with a red rectangular box.</p>                                                                                       |
| 5    | The element has been removed from the database                                  |  <p>The screenshot shows the 'Article dtb' list again. The 'TOMATO' entry is no longer present, and the list starts with '0000 Empty'.</p>                                                                                                                                       |

MAIN FUNCTIONING DESCRIPTION

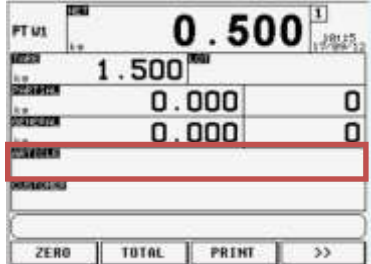
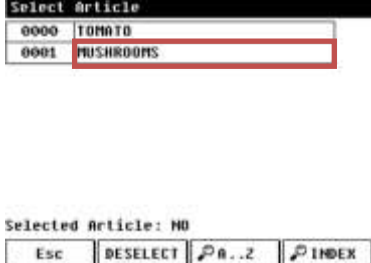
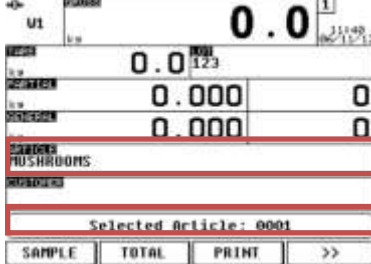
4.4.4 Selection

| Step | Description                                                                                           | Screen                                                                              |
|------|-------------------------------------------------------------------------------------------------------|-------------------------------------------------------------------------------------|
| 1    | Touch the button in the first main screen to get access to the elements present into desired database |   |
| 2    | Touch the desired element to select                                                                   |   |
| 3    | The description of selected element appears on the display                                            |  |

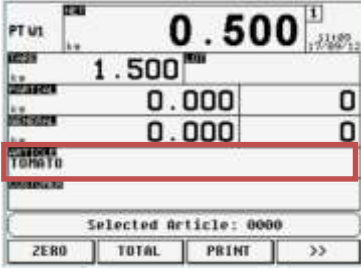

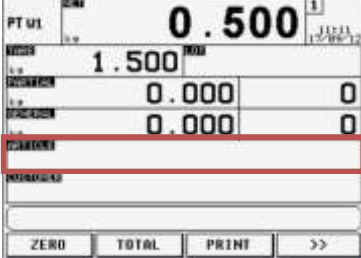
4.4.5 Deselection

| Step | Description                                                                                                      | Screen                                                                                                                                                                                                                                                                                                                                                                                                                                                                                                |
|------|------------------------------------------------------------------------------------------------------------------|-------------------------------------------------------------------------------------------------------------------------------------------------------------------------------------------------------------------------------------------------------------------------------------------------------------------------------------------------------------------------------------------------------------------------------------------------------------------------------------------------------|
| 1    | Touch the button in the first main screen to get access to the elements present into desired database            |  <p>The screenshot shows a main screen with a list of items. At the top, there's a display for 'PT U1' with a price of '0.500'. Below that, there's a list of items with prices: '1.500', '0.000', and '0.000'. The 'TOMATO' item is highlighted with a red box. At the bottom, there are buttons for 'ZERO', 'TOTAL', 'PRINT', and '&gt;&gt;'. The text 'Selected Article: 0000' is visible above the buttons.</p> |
| 2    | A message indicates the index of the selected element. Touch the <b>DESELECT</b> button to deselect this element |  <p>The screenshot shows a 'Select Article' dialog box. It displays '0000 TOMATO' in a text field. Below the text field, it says 'Selected Article: 0000'. At the bottom, there are buttons for 'Esc', 'DESELECT', 'A..Z', and 'INDEX'. The 'DESELECT' button is highlighted with a red box.</p>                                                                                                                    |
| 3    | Press the button to confirm or not the deselection                                                               |  <p>The screenshot shows a confirmation dialog box with the text 'Deselect the record?'. Below the text, there are two buttons: 'No' and 'Yes'. The 'Yes' button is highlighted with a red box. At the bottom, there are buttons for 'Esc', 'DESELECT', 'A..Z', and 'INDEX'.</p>                                                                                                                                   |
| 4    | The description of previous selected element disappears on the display                                           |  <p>The screenshot shows the main screen again. The 'TOMATO' item is no longer highlighted. The 'DESELECT' button at the bottom is highlighted with a red box. The rest of the screen content is the same as in step 1.</p>                                                                                                                                                                                       |

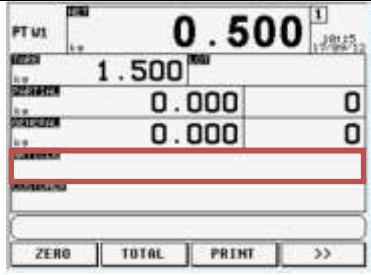
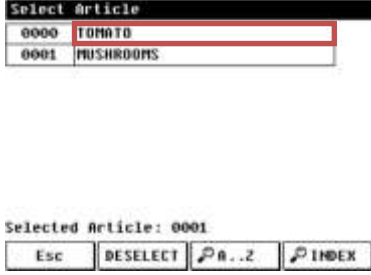
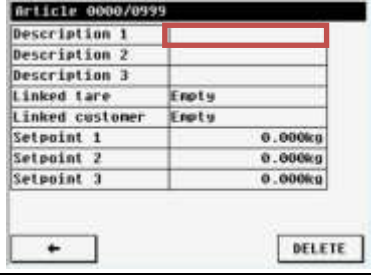
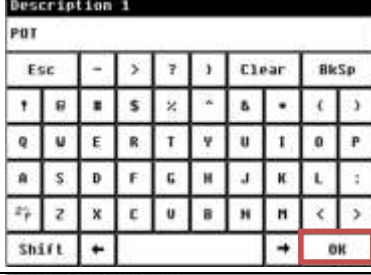
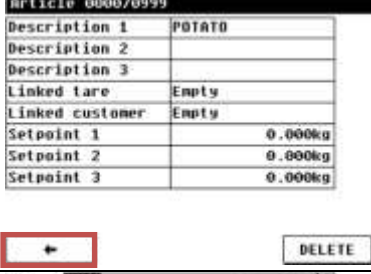
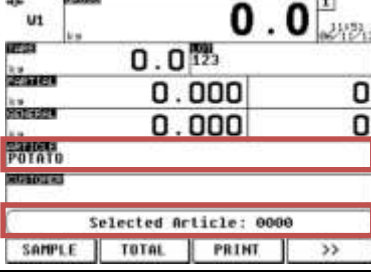

4.4.6 Insertion and quick selection of the temporary element

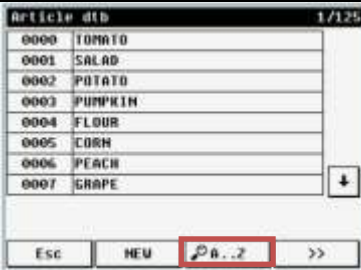
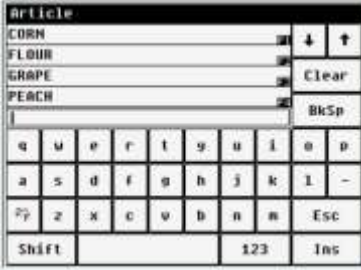
| Step | Description                                                                                                                            | Screen                                                                               |
|------|----------------------------------------------------------------------------------------------------------------------------------------|--------------------------------------------------------------------------------------|
| 1    | Touch the button in the first main screen to get access to the elements present into desired database                                  |    |
| 2    | Touch the element 0000 to insert the temporary element: the previous element will be cleared                                           |    |
| 3    | Touch the first field to insert the content                                                                                            |   |
| 4    | Insert the content of the field and confirm it with the OK button                                                                      |  |
| 5    | Repeat the operation for the desired fields and press the ← button to confirm and select it immediately or the DELETE button to cancel |  |
| 6    | The description of element 0000 appears on the display                                                                                 |  |

#### 4.4.7 Alphanumeric search

| Step | Description                                                                                         | Screen                                                                              |
|------|-----------------------------------------------------------------------------------------------------|-------------------------------------------------------------------------------------|
| 1    | Touch the <b>A..Z</b> button in the database update/selection screen                                |   |
| 2    | Insert the first characters of the element to search                                                |   |
| 3    | The table shows all the elements starting with the typed characters. Then touch the desired element |  |

#### 4.4.8 Search by element index

| Step | Description                                                                                                                                                                                 | Screen                                                                               |
|------|---------------------------------------------------------------------------------------------------------------------------------------------------------------------------------------------|--------------------------------------------------------------------------------------|
| 1    | Touch the <b>INDEX</b> button in the database update/selection screen                                                                                                                       |  |
| 2    | Insert the index of the desired element and confirm. In selection the element is selected and the main screen is displayed. In update the element fields are displayed and can be modified. |  |

#### 4.5 Printouts

The indicator has 22 print functions, each function has an associated format. When a function has been put into execution through the operation illustrated in the scheme, the associated format is sent to the print serial port.

There are 30 available formats to associate to the print functions. To change the format of the print function use MENU → Printout → **Change the printout format**.

| Nr. | Print function                             | Operation / Notes                                                                                                                                                                                               | Format |
|-----|--------------------------------------------|-----------------------------------------------------------------------------------------------------------------------------------------------------------------------------------------------------------------|--------|
| 1   | SIMPLE PRINTOUT                            | <b>PRINT</b> in the main screen toolbar.<br>With the approved instrument the net weight must be greater or equal to 20 divisions.<br>With the non approved instrument the net weight must be greater than zero. | 1      |
| 2   | TOTALISATION                               | <b>TOTAL</b> in the main screen toolbar                                                                                                                                                                         | 2      |
| 3   | PARTIAL TOTAL                              | MENU → Totals → <b>Print partial total</b>                                                                                                                                                                      | 3      |
| 4   | GENERAL TOTAL                              | MENU → Totals → <b>Print general total</b>                                                                                                                                                                      | 4      |
| 5   | GRAND TOTAL                                | MENU → Totals → <b>Print grand total</b>                                                                                                                                                                        | 5      |
| 6   | HEADING OF FIRST TOTALISATION              | <b>TOTAL</b> in the main screen toolbar<br><i>Printed when general totals weighs changes to 1</i>                                                                                                               | 6      |
| 7   | HANDLED ARTICLE TOTAL                      | MENU → Totals → <b>Print article total</b><br>MENU → Totals → <b>Print articles total</b>                                                                                                                       | 7      |
|     | LIST OF WEIGHS CONDITIONED BY THE ARTICLE  | MENU → AF01 functions → <b>Print article list</b><br><i>Formats 8, 9, 10, 11 are related to article weighs list</i>                                                                                             |        |
| 8   | LIST HEADING                               | <i>Printed before the 1st list item</i>                                                                                                                                                                         | 8      |
| 9   | SINGLE WEIGH                               | <i>Single item print format</i>                                                                                                                                                                                 | 9      |
| 10  | SECTOR END                                 | <i>Printed after the set number of items (see print block "Print lines for the weigh list")</i>                                                                                                                 | 10     |
| 11  | LIST END                                   | <i>Printed after the last item</i>                                                                                                                                                                              | 11     |
|     | LIST OF WEIGHS CONDITIONED BY THE CUSTOMER | MENU → AF01 functions → <b>Print customer list</b><br><i>Formats 12,13, 14, 15 are related to customer weighs list</i>                                                                                          |        |
| 12  | LIST HEADING                               | <i>Printed before the 1st list item</i>                                                                                                                                                                         | 12     |
| 13  | SINGLE WEIGH                               | <i>Single item print format</i>                                                                                                                                                                                 | 13     |
| 14  | SECTOR END                                 | <i>Printed after the set number of items (see print block "Print lines for the weigh list")</i>                                                                                                                 | 14     |
| 15  | LIST END                                   | <i>Printed after the last item</i>                                                                                                                                                                              | 15     |
|     | LIST OF ALL THE WEIGHS                     | MENU → Af01 functions → <b>Print weighs list</b><br><i>Formats 16,17, 18, 19 are related to all weighs list</i>                                                                                                 |        |
| 16  | LIST HEADING                               | <i>Printed before the 1st list item</i>                                                                                                                                                                         | 16     |
| 17  | SINGLE WEIGH                               | <i>Single item print format</i>                                                                                                                                                                                 | 17     |
| 18  | SECTOR END                                 | <i>Printed after the set number of items (see print block "Print lines for the weigh list")</i>                                                                                                                 | 18     |
| 19  | LIST END                                   | <i>Printed after the last item</i>                                                                                                                                                                              | 19     |
| 20  | RESULT OF THE CALCULATOR                   | MENU → Generic functions → <b>Calculator</b>                                                                                                                                                                    | 20     |



|    |                        |                                                                                             |    |
|----|------------------------|---------------------------------------------------------------------------------------------|----|
| 21 | HANDLED CUSTOMER TOTAL | MENU → Totals → <b>Print customer total</b><br>MENU → Totals → <b>Print customers total</b> | 21 |
| 22 | PRINT AT START-UP      | <i>Printed at start-up after the auto-zeroing procedure</i>                                 | 22 |

## 4.6 Setpoints

To set the setpoints thresholds follow the path MENU → Generic functions → **Outputs setpoint setting**. A screen like the of Figure 4 is displayed. In the example outputs 1, 2 and 3 are configured with hysteresys disabled (  Digital outputs).

Press one of the three ON values, the usual numeric input screen is displayed. Insert the desired value. At the end press **Esc** to go back to Generic functions menu.

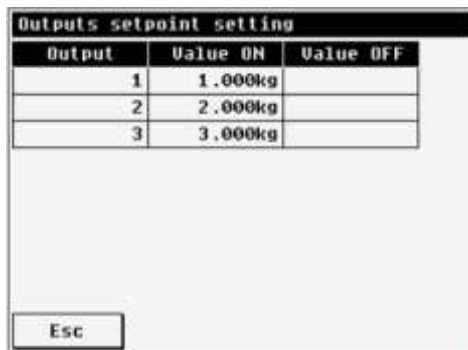

| Outputs setpoint setting |          |           |
|--------------------------|----------|-----------|
| Output                   | Value ON | Value OFF |
| 1                        | 1.000kg  |           |
| 2                        | 2.000kg  |           |
| 3                        | 3.000kg  |           |

Esc

Figure 4. Setpoints thresholds setting



# 5 WEIGHING PROCEDURE

The programme has been made to manage the accumulation and the printing of the weight and quantity. The totalisation takes place in the ways selectable in the technical set-up, described in the following section. The totalised weight and quantity are automatically accumulated in the instrument totals (PARTIAL, GENERAL, GRAND TOTAL), and the weighs' progressives are automatically increased relative to the previously shown totals.

Furthermore, if an article has been enabled, the instrument increases both the totals as well as the weighs' progressive relative to the selected article.

The data that is increased is:

- WEIGH NUMBER
- GROSS WEIGHT TOTAL
- NET WEIGHT TOTAL
- TARE TOTAL

The indicator allows to accumulate the weight on the scale in different modes:

- Totalisation in loading.
- Totalisation in unloading.
- Totalisation both in loading as well as in unloading.

See  **Totalisation type.**

## 5.1 Totalisation in loading

In loading mode positive net weights only are totalised.

To totalise follow the steps below:

1. Put the article on the scale and wait for the weight to become stable
2. Touch the toolbar **TOTAL** button
3. If the weight is not stable the screen of Figure 5 is displayed
4. On totalisation failure the system message "NOT VALID OR UNSTABLE WEIGHT" appears, as in Figure 6
5. On success the totals are incremented (Figure 7) and the printout, if configured, is executed
6. Remove the article from the scale and repeat from step 1 with another article

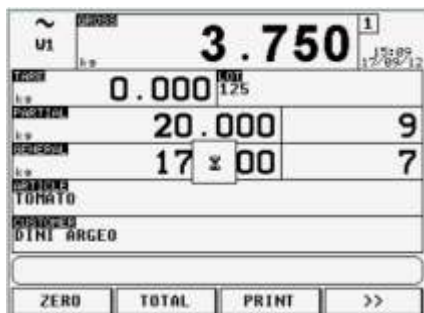

Figure 5. Totalisation underway (loading mode)

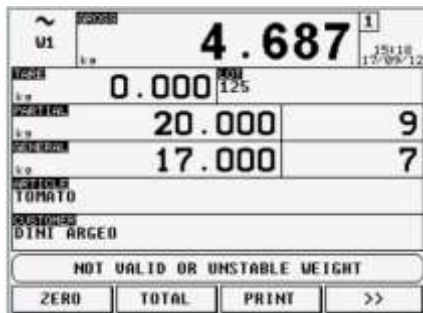

Figure 6. Totalisation failure (loading mode)

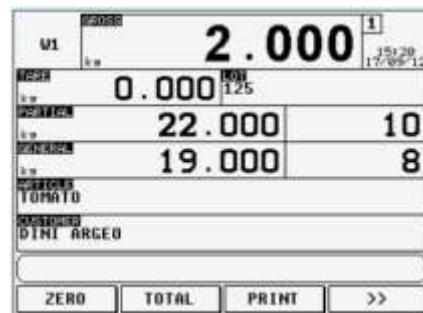

Figure 7. Totalisation success (loading mode)

## 5.2 Totalisation in unloading

In unloading mode negative net weights only are totalised.

To totalise follow the steps below:

1. Put the article on the scale and wait for the weight to become stable
2. Tare the scale by touching the weight area or pressing the tare key
3. Touch the toolbar **TOTAL** button
4. If the weight is not stable the screen of Figure 8 is displayed
5. On totalisation failure the system message "NOT VALID OR UNSTABLE WEIGHT" appears, as in Figure 9
6. On success the totals are incremented (Figure 10) and the printout, if configured, is executed
7. Remove the article from the scale and repeat from step 1 with another article

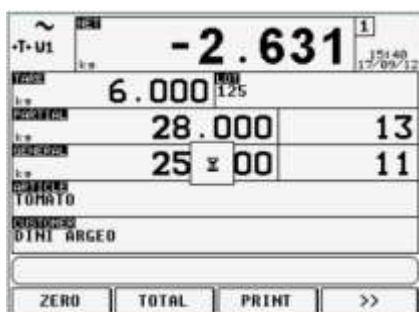

Figure 8. Totalisation underway (unloading mode)

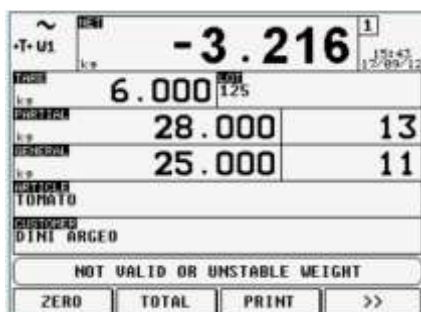

Figure 9. Totalisation failure (unloading mode)

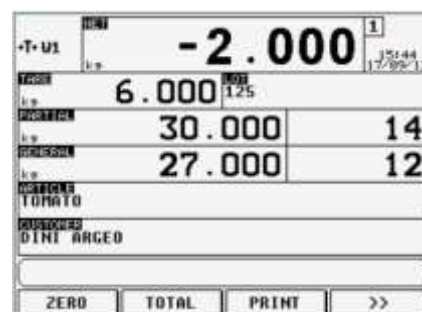

Figure 10. Totalisation success (unloading mode)

## 5.3 Totalisation in loading as well in unloading

This type of totaliser allows to totalise both positive net weights as well as negative net weights.

Follow the steps of section 5.1 for loading totalisation, the steps of section 5.2 for unloading totalisation.

## 5.4 Totalisation with automatic execution of the tare

This function is useful for formulation or dosage applications and allows to automatically tare after the accumulation of the weight on the scale (both in loading as well as in unloading, and manually as well as automatically), allowing to totalise the subsequent one on its own and without unloading the scale.



**Tare after the totalisation.**

## 5.5 Manual or automatic totalisation

The operation of accumulation, normally done manually with **TOTAL** button, can be done automatically when the weight is stable.



**Totalisation mode.**

## 5.6 Totalisation delay

Only with the automatic totalisation is it possible to set a delay for acquiring the weigh, this delay period runs from the weight acquisition and the totalisation.



**Totalisation delay.**

## 5.7 Totalisation field

It is possible to define a weight interval (between 0 and the scale capacity) inside of which it is possible to carry out a totalisation and outside of which the totalization is not accepted. Use of the totalling field is particularly useful when totalling is done automatically with the weight stable.

MENU → AF01 functions → **Minimum (Maximum) threshold.**

## 5.8 Error messages

Error messages that can be displayed when the totalisation function is executed.

| Displayed error message | Type of error                                                                                                                                                                                                                                                                                                                         | What to do                                                                                                                                                                                                                                                      |
|-------------------------|---------------------------------------------------------------------------------------------------------------------------------------------------------------------------------------------------------------------------------------------------------------------------------------------------------------------------------------|-----------------------------------------------------------------------------------------------------------------------------------------------------------------------------------------------------------------------------------------------------------------|
|                         | <ul style="list-style-type: none"> <li>The net weight<sup>(1)</sup> is below the minimum allowed one (20 divisions with approved instrument, zero with non approved instrument)</li> <li>The weight is unstable</li> <li>The net weight<sup>(1)</sup> is below the minimum threshold or greater than the maximum threshold</li> </ul> | <ul style="list-style-type: none"> <li>Load the scale with a weight greater than the minimum allowed one</li> <li>Wait for a stable weight then totalize</li> <li>Load an article with a weight between minimum and maximum thresholds (section 5.7)</li> </ul> |
|                         | <p>The weight hasn't crossed the zero or passed from instability since the last totalisation</p>                                                                                                                                                                                                                                      | <p>Unload the scale then load again</p>                                                                                                                                                                                                                         |

<sup>(1)</sup>In loading mode the net weight must be positive, in unloading or both modes consider the absolute value of the net weight

## 5.9 Conditions for totalisation

With APPROVED instrument:

- The MANUAL and AUTOMATIC totalisation works with a POSITIVE NET WEIGHT of at least 20 divisions (in LOADING) or a NEGATIVE NET WEIGHT of at least 20 divisions (in UNLOADING)
- For totalisation reenabling see **Weighing mode reactivation**
- The totalisation excludes the simple printout and viceversa

With NON APPROVED instrument:

- The MANUAL totalisation works with a NET WEIGHT greater than zero (in LOADING) or a NET WEIGHT lower than zero (in UNLOADING)
- The AUTOMATIC totalisation works with a minimum POSITIVE NET WEIGHT of at least 10 divisions (in LOADING) or a NEGATIVE NET WEIGHT of at least 10 divisions (in UNLOADING)
- For totalisation reenabling see  **Weighing mode reactivation**
- The totalisation does not exclude the simple printout

## 5.10 Progressives

### 5.10.1 Additional value

In MENU→Progressives→**Additional value** it's possible to set a value of up to 6 digits, which is summed to each totalisation, and can be recalled in the printing. The same value is linked independently to three total types (PARTIAL, GENERAL, and GRAND TOTAL), in other words, it is possible to print three different values which will be cleared with the clearing of the relative total.

### 5.10.2 Progressive digits

In MENU→progressives→**Progressive digits** it's possible to set the number of digits with which the TICKET PROGRESSIVE and LOT PROGRESSIVE are printed.

The number of settable digits varies from 4 to 16, organised in this way:

- if the actual digits of the total are less than the number of digits set in this step, the difference is filled with some spaces.
- if the actual digits are greater than the number of digits set in this step, only the ones actually entered are taken into consideration (counting from right to left).

The alignment of the total fields is on the left.

NOTE: The number of settable digits DOES NOT INCLUDE the comma.

### 5.10.3 Ticket progressive

In MENU→progressive→**Ticket progressive**, it's possible to modify or clear the TICKET PROGRESSIVE (up to 5 digits).

The TICKET PROGRESSIVE is a progressive number which increments of one upon the first totalisation subsequent to the clearing of the partial total.

### 5.10.4 Lot progressive

In MENU→Progressive→**Lot progressive**, one obtains the clearing of the AUTOMATIC LOT (up to 6 digits); before carrying out the actual clearing, one is asked to confirm or cancel the operation.

The AUTOMATIC LOT is a progressive number which increments of one upon the first totalisation subsequent to the clearing of the general total.

## **DECLARATION OF CONFORMITY**

This device conforms to the essential standards and norms relative to the applicable European regulations. The Declaration of conformity is available in the web site [www.diniargeo.com](http://www.diniargeo.com).

## **WARRANTY**

The TWO-YEAR warranty period begins on the day the instrument is delivered. It includes spare parts and labour for repairs at no charge if the INSTRUMENTS ARE RETURNED prepaid to the DEALER'S PLACE OF BUSINESS. Warranty covers all defects NOT attributable to the Customer (so are not included in the warranty, failures resulting from improper use) and NOT caused during transport.

If onsite service is requested (or necessary), for any reason, where the instrument is used, the Customer will pay for all of the service technician's costs: travel time and expenses plus room and board (if any).

The customer pays for shipping costs (both ways), if the instrument is shipped to the DEALER or manufacturer for repair.

The WARRANTY is VOIDED if faults occur due to work done by unauthorized personnel or due to connections to equipment installed by others or incorrect connection to the power supply.

This warranty DOES NOT provide for any compensation for losses or damages, direct or indirect, incurred by the Customer due to complete or partial failure of instruments or systems sold, even during the warranty period.

## **AUTHORISED SERVICE CENTRE STAMP**

