

MASTER 311, 311M and 711

Weighframes

Installation Manual

311/311M Weighframe



711 Weighframe



RICE LAKE[®]
WEIGHING SYSTEMS

PN 170735

1.0 Introduction..... 1

- 1.1 Safety 1
- 1.2 Overview 2
- 1.3 Selection Criteria 2
- 1.4 Calibration and Test Weight Device 2

2.0 Installation 3

- 2.1 Mechanical Installation. 4
 - 2.1.1 311/311M Installation 4
 - 2.1.2 Adjusting 311M Length. 6
 - 2.1.3 711 Installation 7
- 2.2 Splice Box Installation 8
- 2.3 Electrical Installation. 8
- 2.4 Commissioning 8
 - 2.4.1 Mechanical Adjustments 8

3.0 Maintenance 9

- 3.1 Maintenance 9
 - 3.1.1 Periodical Maintenance. 9
- 3.2 Dimensional Drawings 9
- 3.3 Specifications 10
- 3.4 Total Load Cell Build 10
- 3.5 List Parameters for Belt Scale 11



Technical training seminars are available through Rice Lake Weighing Systems. Course descriptions and dates can be viewed at www.ricelake.com/training or obtained by calling 715-234-9171 and asking for the training department.

© Rice Lake Weighing Systems. All rights reserved. Printed in the United States of America.
Specifications subject to change without notice.
Rice Lake Weighing Systems is an ISO 9001 registered company.
October 01, 2015



Rice Lake continually offers web-based video training on a growing selection of product-related topics at no cost. Visit www.ricelake.com/webinars

1.0 Introduction

Belt scales measure a continuous mass flow, which is transported over a belt conveyor. A complete belt scale is composed of a weighframe, which contains one or more load cells, a speed sensor/pickup and the integrator electronics.

Not every application is suited for a belt scale; this has to be analyzed by a Rice Lake Weighing Systems specialist. To achieve the optimum result, the Master™ belt scale series has been developed for a number of applications and for every type of conveyor.



Manuals can be viewed and downloaded from the Rice Lake Weighing Systems website at: www.ricelake.com and www.ricelake.eu

Warranty information can be found on the website at: www.ricelake.com/warranties

1.1 Safety

Safety Symbol Definitions



DANGER Indicates an imminently hazardous situation that, if not avoided, will result in death or serious injury.



WARNING Indicates a potentially hazardous situation that, if not avoided, could result in death or serious injury, and includes hazards that are exposed when guards are removed.



CAUTION Indicates a potentially hazardous situation that, if not avoided, may result in minor or moderate injury.



Important

Indicates information about procedures that, if not observed, could result in damage to equipment or corruption to and loss of data.

General Safety



Do not operate or work on this equipment unless you have read and understand the instructions and warnings in this manual. Failure to follow the instructions or heed the warnings could result in injury or death. Contact any Rice Lake Weighing Systems dealer for replacement manuals. Proper care is your responsibility.



Failure to heed may result in serious injury or death.

Some procedures described in this manual require work inside the enclosure. These procedures are to be performed by qualified service personnel only.

Take all necessary safety precautions when installing the scale carriage including wearing safety shoes, protective eye wear and using the proper tools.

Keep hands, feet and loose clothing away from moving parts.

Do not approach a running conveyor from underneath.

Do not bend over a running conveyor.

Do not allow minors (children) or inexperienced persons to operate this unit.

Do not operate without all shields and guards in place.

Do not jump on the scale.

Do not use for purposes other than weight taking.

Do not place fingers into slots or possible pinch points.

Do not use any load bearing component that is worn beyond 5 percent of the original dimension.

Do not use this product if any of the components are cracked.

Do not exceed the rated load limit of the unit.

Do not make alterations or modifications to the unit.

Do not remove or obscure warning labels.

1.2 Overview

The weighframe model *Master 311/711 Series* is designed for medium and heavier applications in the process industry, where accuracy and/or legal approval is required.

The dimensions are extracted from the construction of the existing, or to-be built, belt conveyor.

Theory of Operation

The material is carried by the belt and underlying rollers or idler stations. One or more of these idlers are mounted on the weighframe and are used to weigh the material going across the belt. The material carried on the belt is weighed and the belt speed is measured. Both values (belt load and belt speed) are calculated in an integration function. The integrator totals and calculates the mass flow. These values are displayed and transmitted through outputs or other forms of communication to a control system or network.

For the operation, refer to the manual of the electronics installed.

1.3 Selection Criteria

Load cell capacity is calculated based on the maximum belt load plus the dead load of the weighframe and the weight of the rollers. Contact Rice Lake Weighing Systems technical support for assistance.

Net load = (conveyor capacity / belt speed) x idler spacing

Gross load = net load + (idler weight + belt weight + mounting hardware)

Examples:

Net load = (20,000 lb (9,072 kg) per minute / 400 ft (122 m) per minute) x 4 ft (1.22 m) spacing

Net load = (50 lb (23 kg) per ft) x 4 ft (1.22 m) spacing

Net load = 200 lb (91 kg)

Gross load = 200 lb (91 kg) + (175 lb (79 kg) idler + 48 lb (22 kg) belt + 24 lb (11 kg) hardware)

Gross load = 447 lb (203 kg)

1.4 Calibration and Test Weight Device

Mounting points can be provided to apply static test weights. Test weights are used to test repeatability and the state of the belt scale after initial calibration.

To determine absolute accuracy, it is necessary to do a test with material. For this procedure, refer to the manual of the electronics installed.

2.0 Installation

Installation procedures generally should be a combination of the end user's best engineering practices in compliance with local codes and the manufacturer's recommendations. To achieve maximum performance, the following precautions should be observed.



- *Take all necessary safety precautions when installing the scale carriage including wearing safety shoes, protective eye wear and using the proper tools.*
- *Always turn off the power supply before any connection is made or removed.*
- *Before welding, the power supply must be off and the connectors removed.*



- *The load cell is very sensitive to damage by welding. The welding ground clamp must be attached to the same side of the weighframe where welding. When in doubt, remove the load cell(s).*
- *Follow the recommendations given when the application was checked.*
- *Belt conveyor must be installed in a stable and rigid area, free from vibrations.*
- *The construction of the belt frame must be stiff enough to prevent torsion or bending at the maximum load (including the weighframe).*
- *The weighframe must be mounted free of mechanical tensions.*
- *No vibrations in the conveyor should be allowed to carry over to the weighframe. If needed, these must be filtered.*
- *The belt must be of good quality and a single splice. A vulcanized splice will provide the best accuracy. The weight per foot (meter) should be consistent over the whole length.*
- *The belt must not track out of the center and no steering idler must be placed near the weighing area.*
- *The belt support must not be supported with two-part (v-shape) idler stations.*
- *At least three idler stations before and three idler stations after the weighframe (the weighing section) have to be adjustable in height. For short belt conveyors this can be reduced to one roller before and one roller after the weighframe.*
- *String alignment should be used on all idlers in the scale system. If following the rule of three before and three after, seven idlers (including the weigh idler) should be checked during the alignment process.*
- *Rollers should not have a concentricity exceeding +/- 0.012 in (0.3 mm).*
- *The speed sensor should be mounted on a non-driven roller or drum.*
- *The inclination angle of the belt conveyor must not exceed 12%.*
- *Proper covers may be required to prevent air flow from interfering with the belt scale.*
- *Side guards and belt skirting should not be in contact with the weighing area of the belt scale.*

2.1 Mechanical Installation

The mechanical installation of a belt scale consists of mounting the belt scale, the speed pickup and the junction box. Three types of scale installation are included in this manual:

311 – a weighframe that is made to order, lengths will vary.

311M – a modular weighframe, the width can be adjusted in the field for smaller conveyors.

711 – a pivot weighframe that is made to order, lengths will vary.

2.1.1 311/311M Installation

The *311/311M* width can be adjusted slightly to fit across the stringers of the belt conveyor.



Note *The length of the 311M can be shortened, see Section 2.1.2 on page 6.*

1. Determine the location for the belt scale. This location should be at least five idlers after the load point of the conveyor and at least five idlers before the head pulley.
2. Remove the belt from the selected area.
3. Remove the existing idler where scale is to be located.

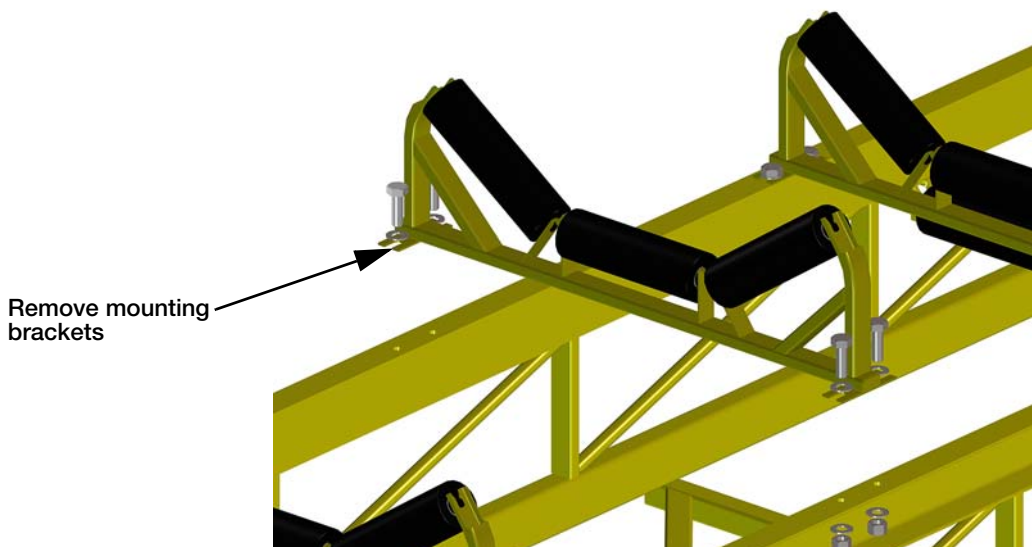

Figure 2-1. Remove Existing Idler

4. Remove any mounting brackets that may be attached to the idler.
5. Adjust the weighframe to fit between the conveyor frame stringers. To adjust the end brackets, loosen the bolts allowing the bracket to slide back and forth in the bracket slots. Ensure the length of the slots are sitting on the conveyor stringers.

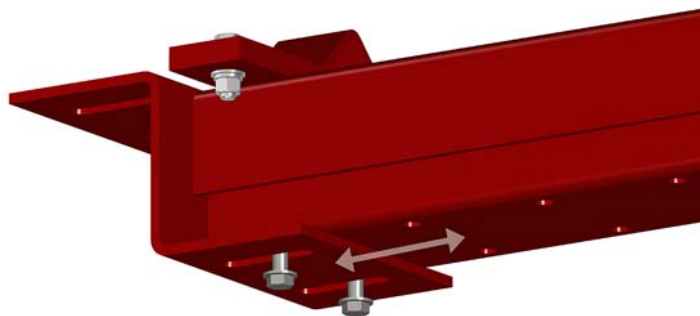

Figure 2-2. Adjust Belt Scale Width

6. Align the weighframe mounting bracket slots with the holes used for anchoring the idler.
7. Use the existing hardware from the idler to secure the weighframe to the conveyor stringers.

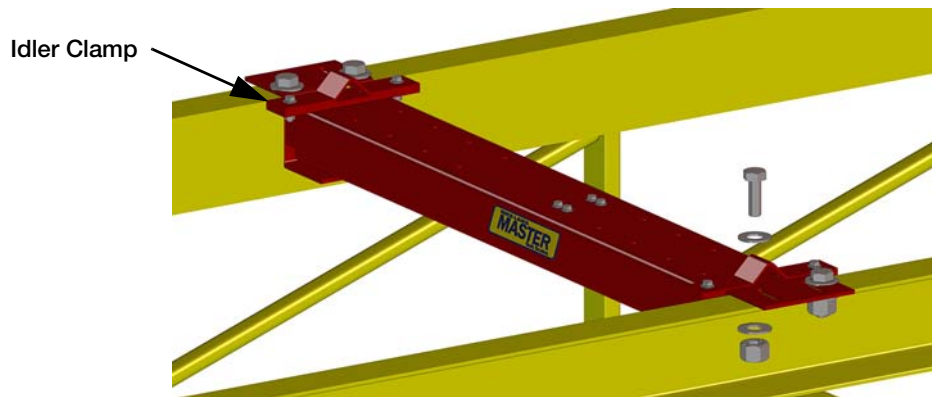

Figure 2-3. Installed 311/311M Weighframe

8. Remove the idler clamps from the weighframe assembly.
9. Place the idler on top of the weighframe.
10. Place the idler clamps on the idler bottom stringer and secure with bolts, washers and nuts.

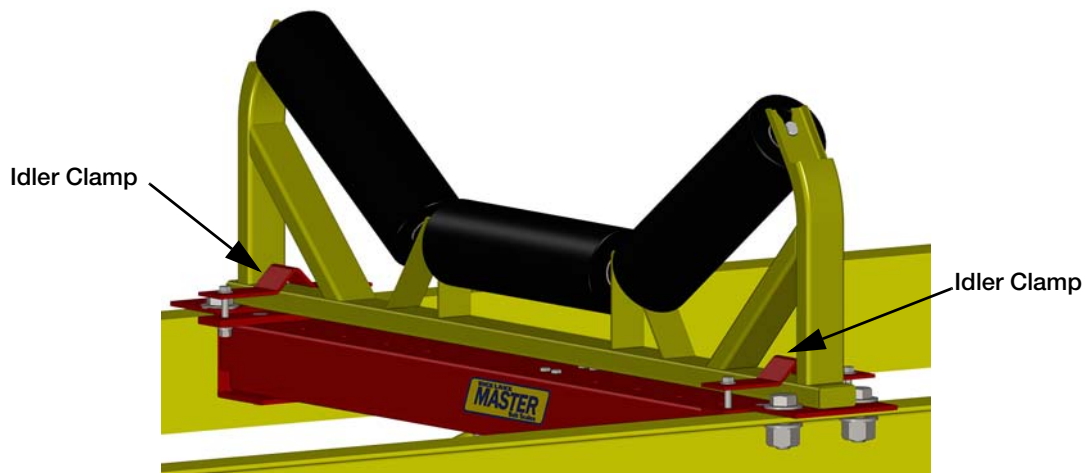

Figure 2-4. Install Idler On Weighframe

11. Run strings on the conveyor (three before the scale and three past the scale) and shim the idlers to the same plane.

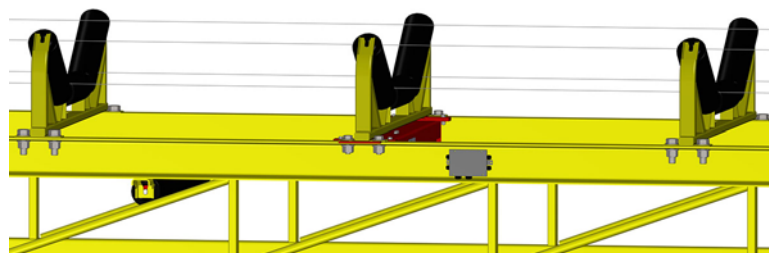

Figure 2-5. Run Strings To Same Plane



Note Shims are not included with scale. They are available separately.

2.1.2 Adjusting 311M Length

1. Measure the distance between the stringers at the location selected for the belt scale.

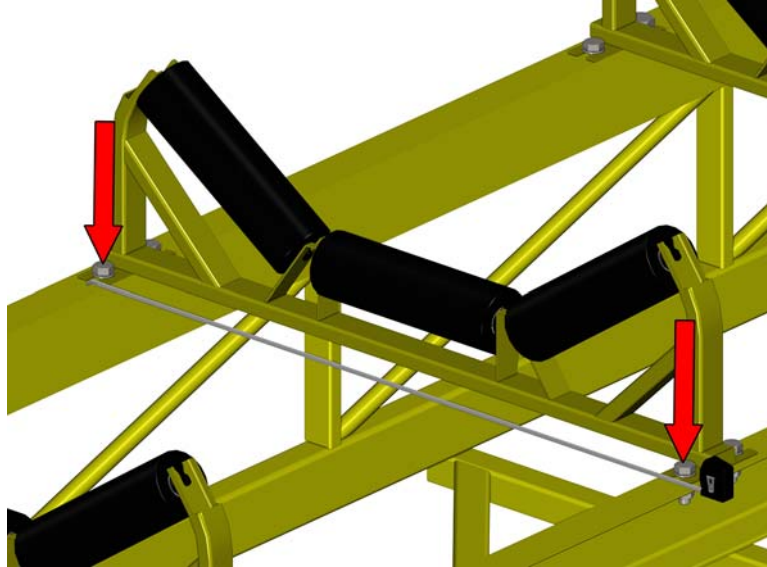

Figure 2-6. Measure Length Between Stringers

2. Remove angle bracket, flat plate and idler clamp from both ends of weighframe.
3. Using the measurement from step one determine how much needs to be cut off from the weighframe. Divide this number by two; this is the amount to be cut off from each end of the weighframe.
4. Measure carefully from each end of the weighframe to cut off the exact same amount on each side.



Important Carefully measure each end of the weighframe. The exact same amount must be removed from each side to ensure accurate weighing.



Figure 2-7. Resize Weighframe – 311M Only

5. Reinstall angle bracket, flat plate and idler clamp to both ends of weighframe.
6. Proceed with installation. See Section 2.1.1.

2.1.3 711 Installation

1. Determine the location for the belt scale. This location should be at least five idlers after the load point of the conveyor and at least five idlers before the head pulley.
2. Remove the existing idler where scale is to be located.

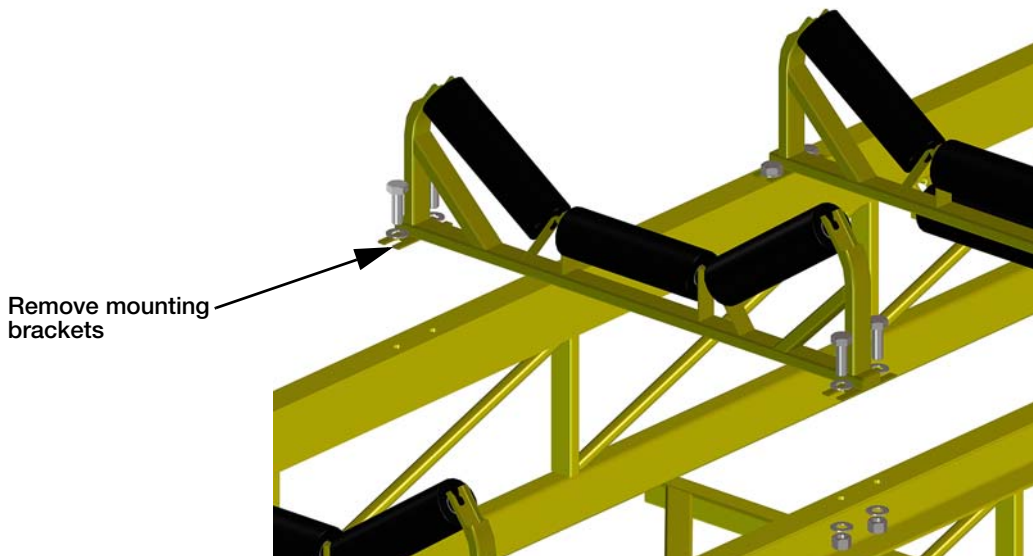

Figure 2-8. Remove Existing Idler

3. Remove any mounting brackets that may be attached to the idler.
4. Align the weighframe mounting bracket slots with the holes used for anchoring the idler.
5. Use the existing hardware from the idler to secure the weighframe to the conveyor stringers.

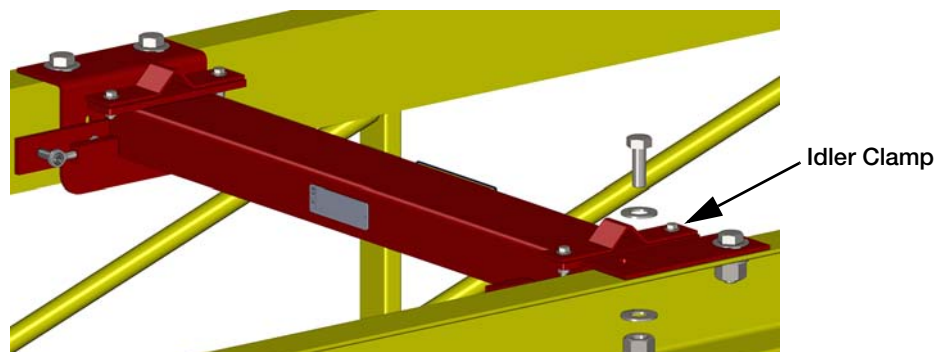

Figure 2-9. Installed 711 Weighframe

6. Remove the idler clamps from the weighframe assembly.
7. Place the idler on top of the weighframe.
8. Place the idler clamps on the idler bottom stringer and secure with bolts, washers and nuts.

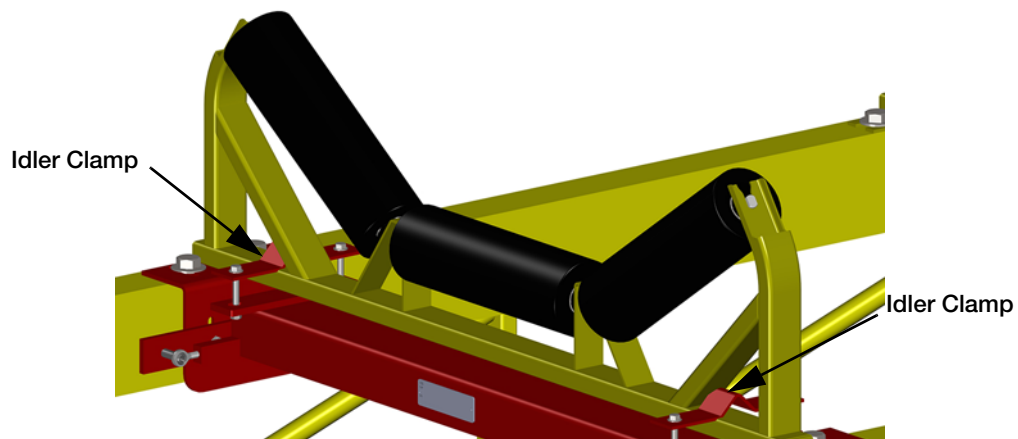

Figure 2-10. Install Idler on 711 Weighframe

9. Run strings on the conveyor (three before the scale and three past the scale) and shim the idlers to the same plane. See Figure 2-5 on page 5.

Transport Lockout

The 711 is equipped with a transport lockout, to engage when conveyor is being moved.

Transport Belt Scale

1. Loosen jam nut.
2. Turn transport bolts in to remove load from load cell.
3. Tighten jam nut so bolt cannot change position.

To Use Belt Scale

1. Loosen jam nut.
2. Turn transport bolts out to allow load onto load cell.
3. Tighten jam nut so bolt cannot change position.

2.2 Splice Box Installation

1. Mount the splice box in an appropriate location.

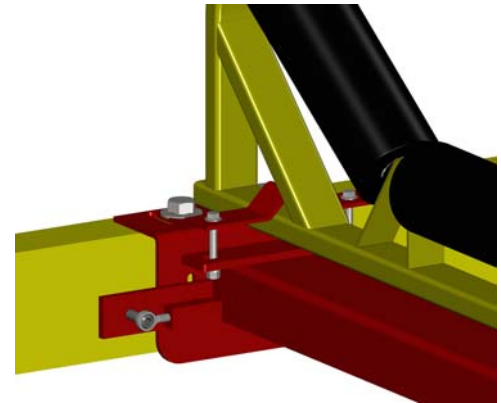

Figure 2-11. Transport Lockout

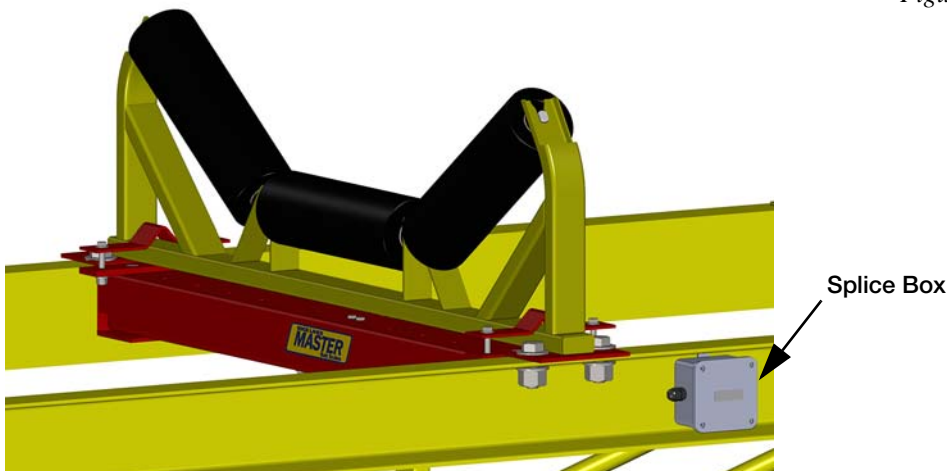

Figure 2-12. Mount Splice Box

2. Wire load cells according to the load cell data sheets.
3. Terminate homerun cable at the splice box and integrator.
4. Calibrate the scale using the calibration procedure for the applicable integrator.

2.3 Electrical Installation

The wiring and connections between the weighframe, speed pickup and the electronics are shown in the applicable scheme. See Section 3.3 on page 10.

The load cell is provided with a fixed cable; do not alter the length. If necessary, use an additional junction box with screw terminals to extend the cable length.

Cable Types

Load cell

If the length is more than 197 ft (60 m), use shielded 6 wire cable 20 AWG gauge (0.5 mm²).

Speed pickup

Use shielded 3 wire cable 20 AWG gauge (0.5 mm²).

Cable shielding

Cable shielding must be connected to one side only. If connected to the instrument side, then it is preferred to use the same ground as the power supply.

2.4 Commissioning

Commissioning should be performed by service engineers who are trained and experienced with the subject.

2.4.1 Mechanical Adjustments

Mechanical adjustments must be made to ensure the scale is free of any tension. If necessary, the load cell can be adjusted.

3.0 Maintenance

Regular maintenance is essential to prevent errors or unnecessary down time. The supplier does not accept any responsibility for the consequences of not performing the maintenance recommended in this section.

3.1 Maintenance



WARNING

It is important to ensure the safety of personnel during maintenance work and that no accidents will happen. Before any work on electrical systems is started, be sure to remove the main power supply.

The conveyor must be shut off before any work on the conveyor is started. Any goods on the conveyor must be removed first. No unauthorized persons are allowed in the conveyor's working area.

3.1.1 Periodical Maintenance

To keep the belt scale in optimal condition, it is important to perform periodical maintenance.

- Ensure there is not a build up of debris on the belt.
- Inspect the weighframe for damaged areas and repair as necessary.
- Regularly perform an *Auto Zero* and a weight check with certified test weights to determine if the belt scale weighs correctly. For this procedure, refer to the manual of the electronics installed.

3.2 Dimensional Drawings

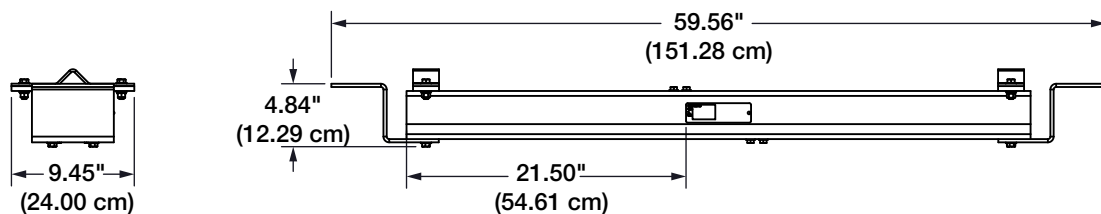

311/311M Weighframe



Note

The 311 lengths will vary, they are made to order.

The length of the 311M can be shortened, see Section 2.1.2 on page 6.

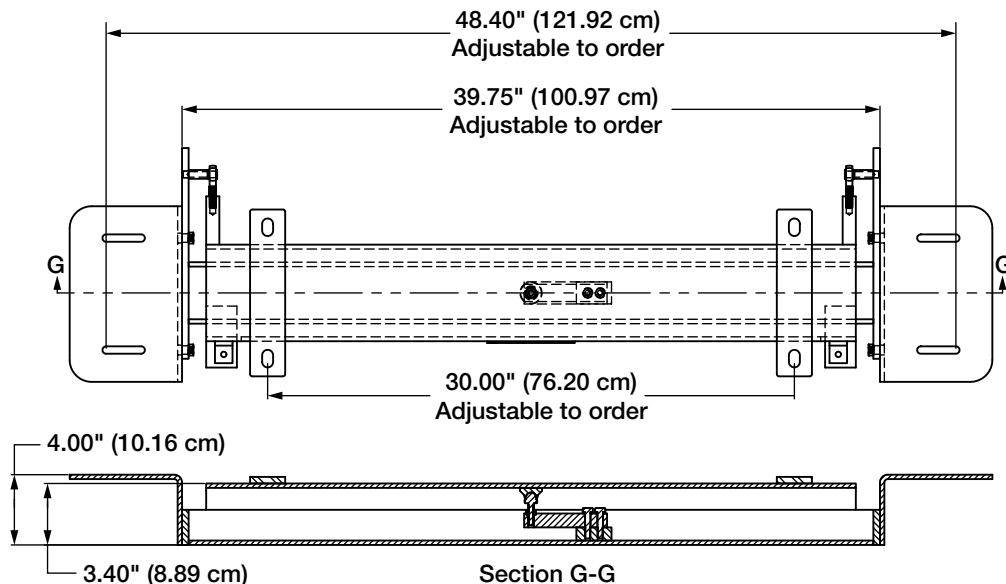

711 Weighframe



Note *The 711 lengths will vary, they are made to order.*

Figure 3-1. Dimensions

3.3 Specifications

Standard

Weighframe Material Powder coated mild steel or stainless steel SS304 / 316
Weight Approximately 104 lb (47 kg), not including the idler
Load Cell 1 potted single point load cell
Capacity 50 to 250 kg (each)
Power supply 5-15 VDC (stabilized from electronics)
Signal nominal 2 mV/V at 100% load

3.4 Total Load Cell Build

The *Master 311/711 Series* has a single load cell. Table 3-1 outlines the total load cell build, this value is used for the theoretical calibration.

Load Cell Capacity	Imperial	Metric
50 kg	110 lb	50 kg
100 kg	220 lb	100 kg
250 kg	550 lb	250 kg

Table 3-1. Total Load Cell Build Conversion

3.5 List Parameters for Belt Scale

Complete the information below. Remove this page and store in a secure location.

CUSTOMER	_____
ORDER NUMBER	_____
INSTALLATION	_____
REFERENCE	_____
TYPE WEIGHFRAME	_____
TYPE SPEED PICKUP	_____
TYPE ELECTRONICS	_____
DATE	_____
FILLED IN BY	_____

Parameter	Unit	Entered	Change
Nominal capacity (flow)	lb/hr (kg/hr)	_____	_____
Maximum capacity (flow)	lb/hr (kg/hr)	_____	_____
Minimum capacity (flow)	lb/hr (kg/hr)	_____	_____
Ratio weighframe		_____	_____
Number of load cells		_____	_____
Load cell capacity (per loadcell)	lb (kg)	_____	_____
Load cell sensitivity	mV/V	_____	_____
Idler spacing	in (mm)	_____	_____
Belt angle of incline	°	_____	_____
Belt speed	ft/s (m/s)	_____	_____
Speed pickup:		_____	_____
Pulses per revolution		_____	_____
Non-driven drum	in (mm)	_____	_____
Total belt length	ft (m)	_____	_____



© Rice Lake Weighing Systems Specifications subject to change without notice.
Rice Lake Weighing Systems is an ISO 9001 registered company.

230 W. Coleman St. • Rice Lake, WI 54868 • USA
U.S. 800-472-6703 • Canada/Mexico 800-321-6703 • International 715-234-9171 • Europe +31 (0)26 472 1319

www.ricelake.com www.ricelake.mx www.ricelake.eu www.ricelake.co.in m.ricelake.com