

102DHM3

Alloy Steel

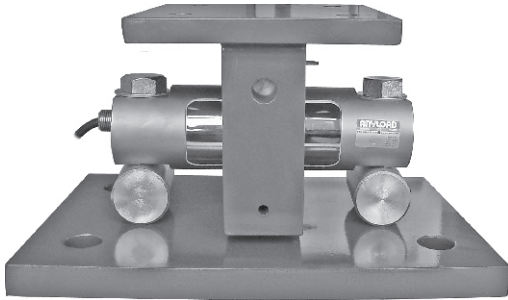

Features:

- Assembles: 102DH double ended beam load cell
- Capacities: 5Klb-250Klb
- Center pivoted and self-checking with anti-lifting protection
- Sliding pin design compensates for thermal expansion and contraction

Load Cell Certifications:



Load Cell Not Included.

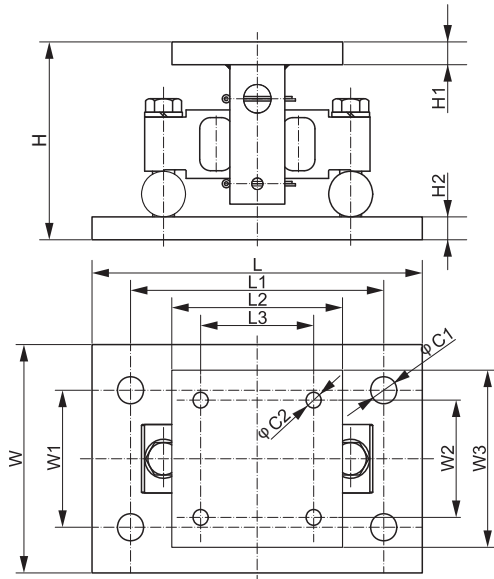

DIMENSIONS

LOADCELL CAPACITY	C1	C2	H	H1	H2	L	L1	L2	L3	W	W1	W2	W3
Klb/inches													
5-20	1.06	0.56	5.30	0.50	0.75	11	8.00	5.50	3.00	7.50	4	3.00	5.50
30-75	1.19	0.68	8.41	0.75	0.94	15	11.5	7.76	5.12	10.0	6	5.12	7.76
100-150	1.38	0.81	9.63	1.00	1.25	18	14.0	10.0	7.50	12.0	9	7.50	10.0
200-250	1.88	1.06	14.58	1.25	1.50	24	20.0	12.0	9.00	12.0	8	9.00	12.0
t/mm (conversion of above dimensions)													
2.3-9.1	26.9	14.2	134.6	12.7	19.1	279.4	203.2	139.7	76.2	190.5	101.6	76.2	139.7
13.6-34	30.2	17.3	213.6	19.1	23.8	381.0	292.1	197.0	130.0	254.0	152.4	130.0	197.0
45.4-68	35.1	20.6	244.6	25.4	31.8	457.2	355.6	254.0	190.5	304.8	228.6	190.5	254.0
90.7-113.6	47.8	26.9	370.3	31.8	38.1	610.0	508.0	304.8	228.6	304.8	203.2	228.6	304.8

PART NUMBER		
Load Cell Capacity	Part No.	Shipping Weight (kg) Approx.
5Klb-20Klb	102DHM3-(5-20)Klb	13.0
30Klb-75Klb	102DHM3-(30-75)Klb	38.8
100Klb-150Klb	102DHM3-(100-150)Klb	62.0
200Klb-250Klb	102DHM3-(200-250)Klb	150.0

INTERCHANGEABLE PRODUCTS	
Manufacturer	Model
Rice Lake	EZ Mount 1