

LTP

Forklift hydraulic weighing system

INSTALLATION AND OPERATING INSTRUCTIONS

ENGLISH

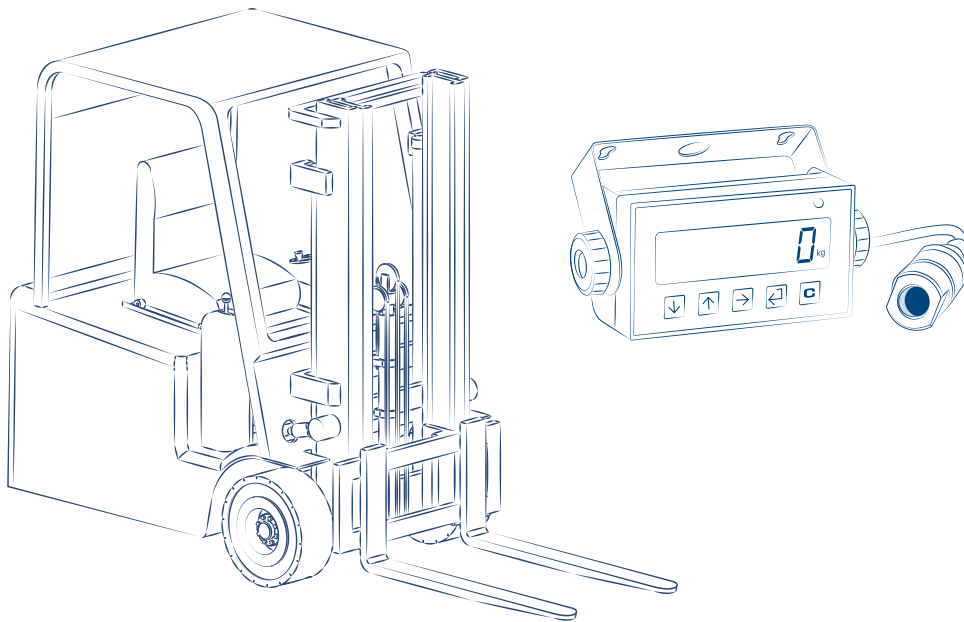

Introduction	4
Weighing system specifications	4
Warnings	5
Forklift requirements	5
Kit components	6
Weight indicator	6
Pressure sensor	8
Fixing bracket for the indicator in the cabin	8
Reference stickers	8
Kit installation	10
Before installation	10
Sensor installation	11
Installing the indicator	12
Applying reference stickers	14
Calibration	15
Calibration linearisation	19
Additional parameters (for experienced users only)	20
Programming menu	22
Communication strings	43
Wiring diagram	44
Error messages	45
Summary of the parameters	46
Notes	48

Introduction

Dear Customer,
Thank you for purchasing a DINI ARGEO product.

This manual explains the installation and commissioning for the hydraulic weighing system for forklifts.
In particular, the installation of the sensor and the calibration of the indicator are described (with the corresponding adjustable ranges of values and practical programming examples) to assist the technician during system installation.

For any additional information or specific requests, please contact your local dealer.

This publication is optimised for A4 printing.

POWER SUPPLY	5 Vdc, via external power supply unit.
MAXIMUM CAPACITY	4000 PSI / 280 bar.
RECOMMENDED RESOLUTION	20 kg for capacities up to 2500 kg. 50 kg for capacities up to 5000 kg. 100 kg for capacities up to 10000 kg.
RECOMMENDED MINIMUM WEIGHT	10 reading divisions.
PROTECTION RATING OF THE SENSOR	IP65.
DISPLAY	Backlit 25mm LCD with 6 high contrast digits and icons to indicate active functions.
KEYPAD	Membrane, 5 keys.
PRINTER	Optional (code OBTPRLT). <i>Requires power from the forklift</i>

Warnings

- The weighing system does not change the safety regulations normally applied to the forklift.
- Before weighing, make sure that the forklift is stationary, on a flat surface and that there are no people in the area around the load.
- The employee training on the use of the system is the purchaser's responsibility.
- Please read this manual carefully before using the system.
- Assistance must only be carried out by personnel authorised by Dini Argeo.
- Dini Argeo is not responsible for any weighing errors resulting from improper use of the system.

Forklift requirements

For proper operation of the system, the forklift must meet the following requirements:

- Minimum friction between the sliding parts.
- No oil leaks.
- Good lubrication of the mast and chains.
- Good level of cleanliness.
- Use of an oil with a high viscosity index.

To make the system repeatable (i.e. to display the same weight when weighing in succession), the forklift must be kept in constant condition, therefore regular cleaning and maintenance must be carried out.

Kit components

The LTP kit consists of:



- Weight indicator
- Pressure sensor
- Fixing bracket to the forklift
- Reference stickers
- Power supply unit (optional)
- Thermal printer (optional)



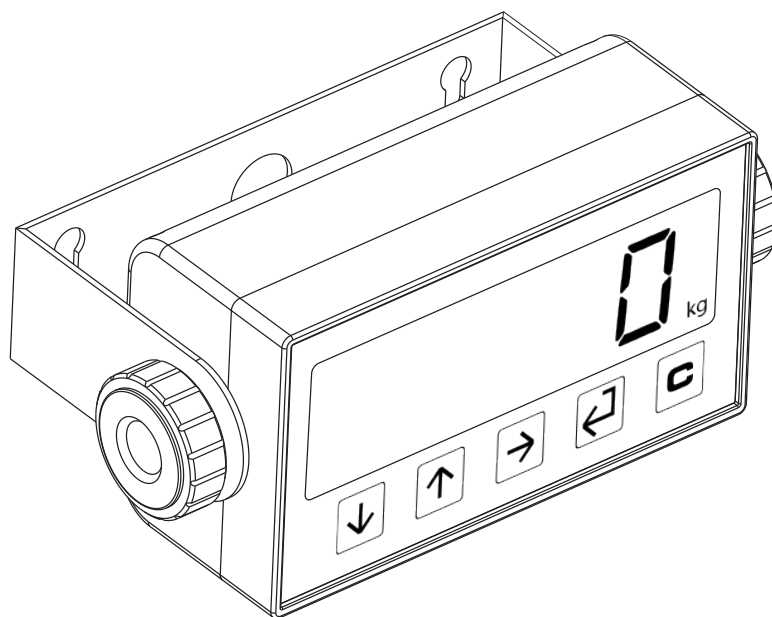

1. Weight indicator

Powered directly from the forklift battery (via optional internal power supply), 5-key keypad and LCD
Vertical tilt can be adjusted via the integrated bracket.





ITEM	ICON	DESCRIPTION
1	→0←	This indicates that the scale is empty (gross zero).
2	~	This indicates that the weight is unstable.
3	NET	The net weight is displayed. Note: A tare has been stored.
4 / 5	G B	The gross weight is displayed.
6		This indicates the battery level: 
7	LT	A tare has been blocked.
8	PT	A manual tare is active.
9	lb ... kg	This indicates the unit of measure: pounds (lb), tons (t), kilograms (kg), grams (g).
10	*	This indicates that a key has been pressed. In some operating modes, this indicates that a specific function is active.
11	----	Weight acquisition phase.

Key	Description
	<ul style="list-style-type: none"> For numerical entries, decreases the value. If pressed for a long time (2 sec), it allows you to set the brightness of the display.
	<ul style="list-style-type: none"> For numerical entries, increases the value. If pressed for a long time (2 sec) it allows you to insert a preset tare.
	<ul style="list-style-type: none"> Recalls the function specific to the operating mode. For numerical entries, to change the selected digit If pressed for a long time (5 sec) it allows you to change the operating mode.
	<ul style="list-style-type: none"> Confirm key. Print the receipt. If pressed for a long time (5 sec) it allows you to enter the configuration menu.
	<ul style="list-style-type: none"> If pressed for 2 seconds, it turns off the instrument. If pressed for 5 sec it shows the metrological information.

2. Pressure sensor

Stainless steel sensor, IP65 protection rating and hydraulic connector with 1/4 inch parallel PSB female.
Sensor dimensions: length: 73.5 mm; diameter: 24.5 mm.



3. Fixing bracket for the indicator in the cabin

Bracket for horizontal adjustment during installation.

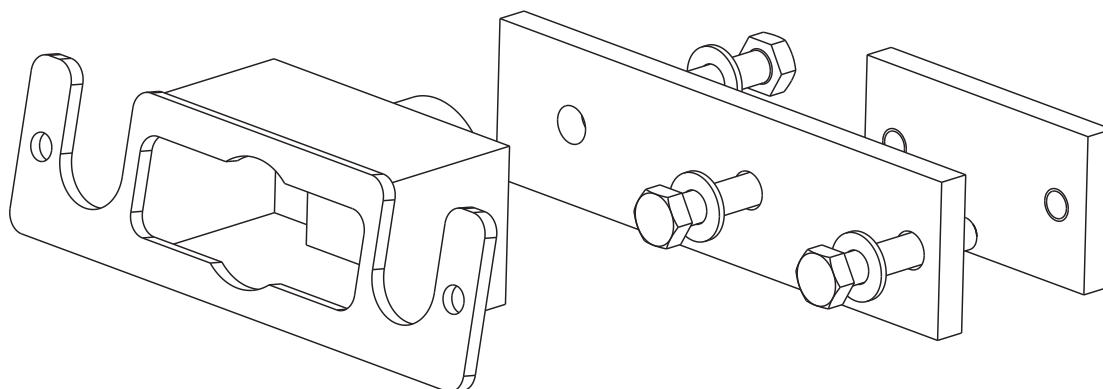

4. Reference stickers

Stickers used to identify the height range of the forks within which the weighing operations are to be carried out.
To be applied to the structure of the forklift.

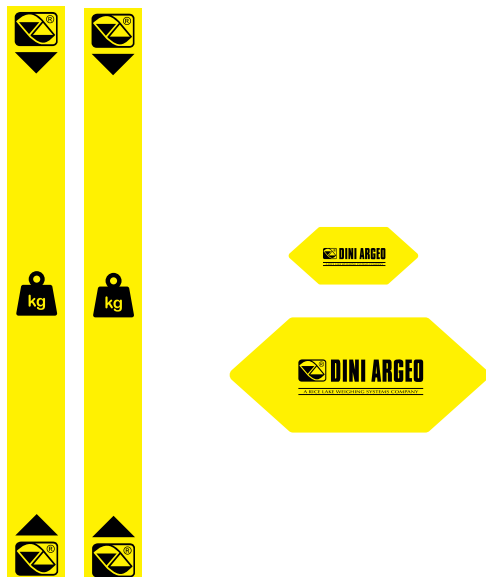

5. Power supply unit (optional)

The appropriate optional ALxxV5 power supply unit with 18 to 72Vdc or 40 to 160Vdc input can be chosen according to the voltage on the forklift. The ALxxV5 power supply units can be installed inside the weight indicator and can simultaneously power the OBTPRLT printer, optimising the wiring of the various components.

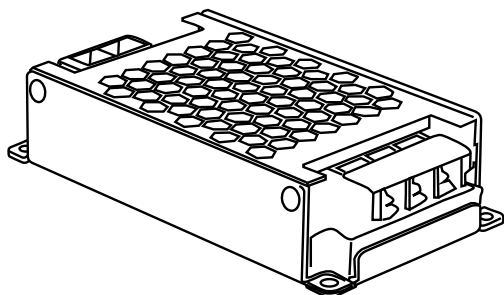

6. Thermal printer (optional)

OBTPRLT thermal printer with integrated bracket for fixing to the forklift. Powered directly from the weight indicator (if optional internal power supply unit is present).

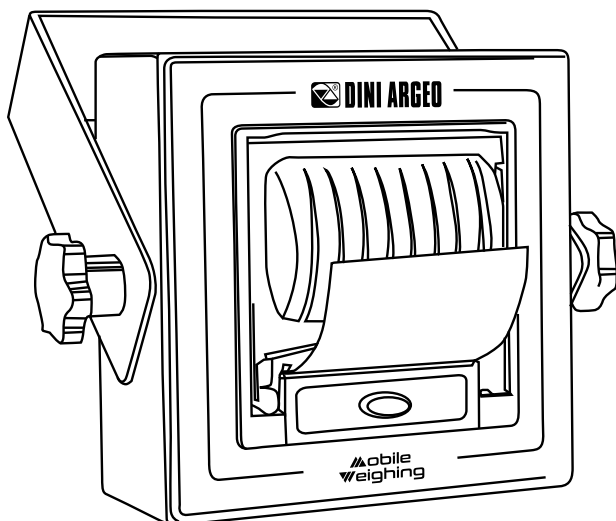

Before installation

- Check that the maximum oil pressure is lower than the maximum value indicated on the sensor datasheet (4000 psi = 280 bar).
- Remove the pressure in the hydraulic circuit; this can be done in two ways:

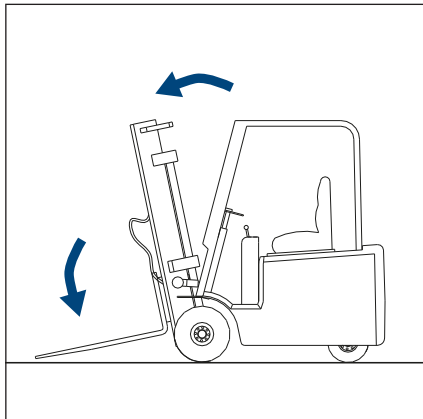

A. Lower the forks to their maximum and move forward.
Make sure the chain is loose.

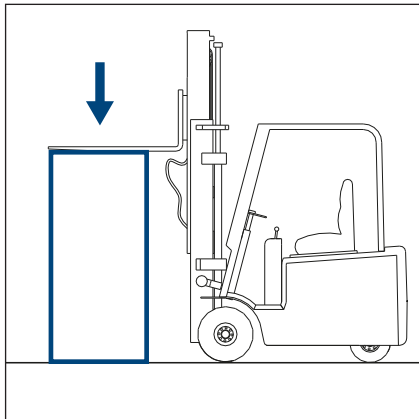

B. Place the forks on a stable object.
Make sure the chain is loose.

Sensor installation

The sensor is connected to the hydraulic system of the forklift using a compatible tee fitting (*not included in the kit*). Install the sensor in the pressure pipe that guides the cylinder (the sensor should be positioned as close as possible to the cylinder).

The sensor must be installed with the cable pointing downwards. This prevents air from entering the sensor.

For intensive use of the forklift, it is advisable to use a tube of about 50 cm between the tee fitting and the sensor. By moving the sensor away from the heat source, accuracy will not be adversely affected by temperature (e.g. motor, batteries, etc.).

SENSOR MOUNTING ON SINGLE-CYLINDER FORKLIFTS

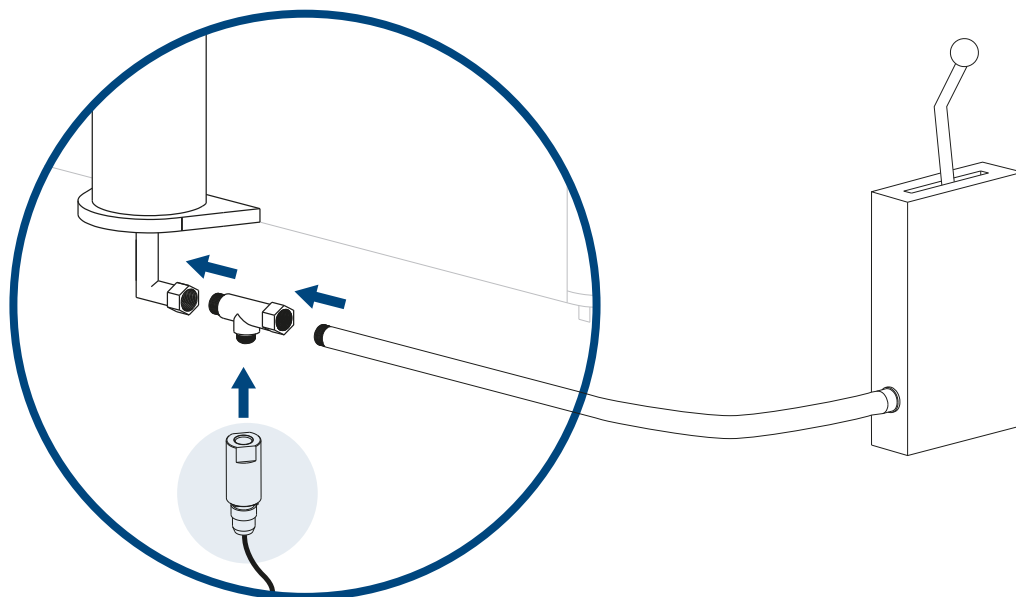

SENSOR MOUNTING ON DOUBLE-CYLINDER FORKLIFTS

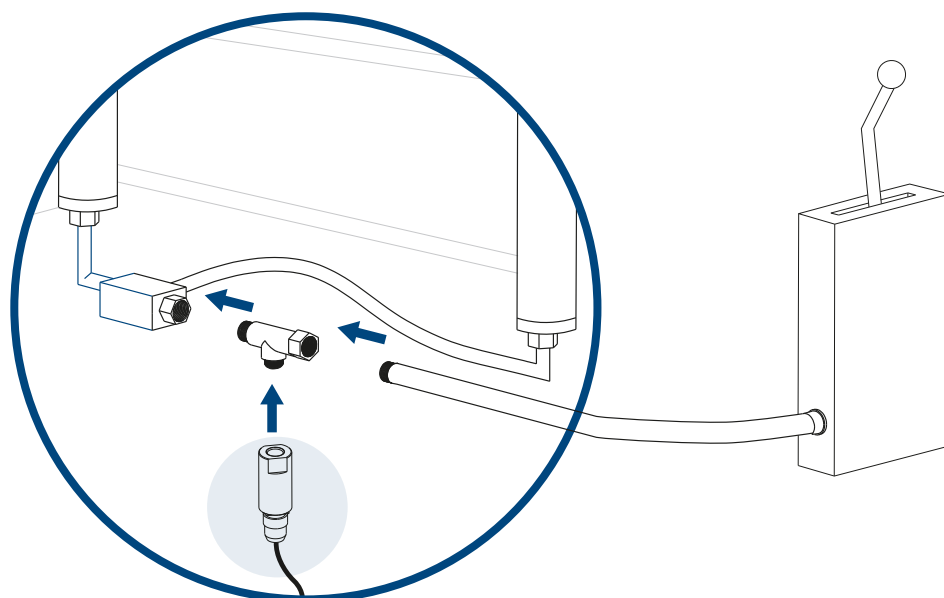

i Mount the sensor before splitting the pressure hose.

Installing the indicator

FIND A SUITABLE LOCATION FOR THE INDICATOR:

Below are some installation examples:

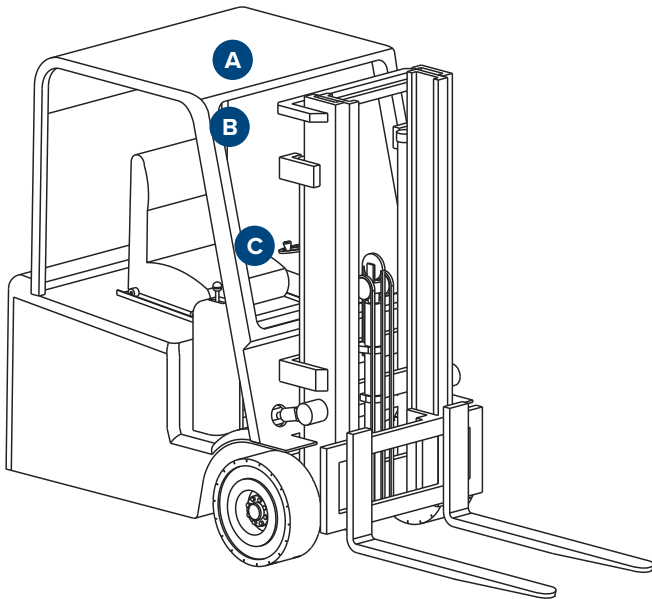

Adjust the orientation of the indicator vertically *and* horizontally so that it is clearly visible and easy to reach.

INSTALLING THE INDICATOR BRACKET

Install the bracket to the indicator using the supplied fixing components.

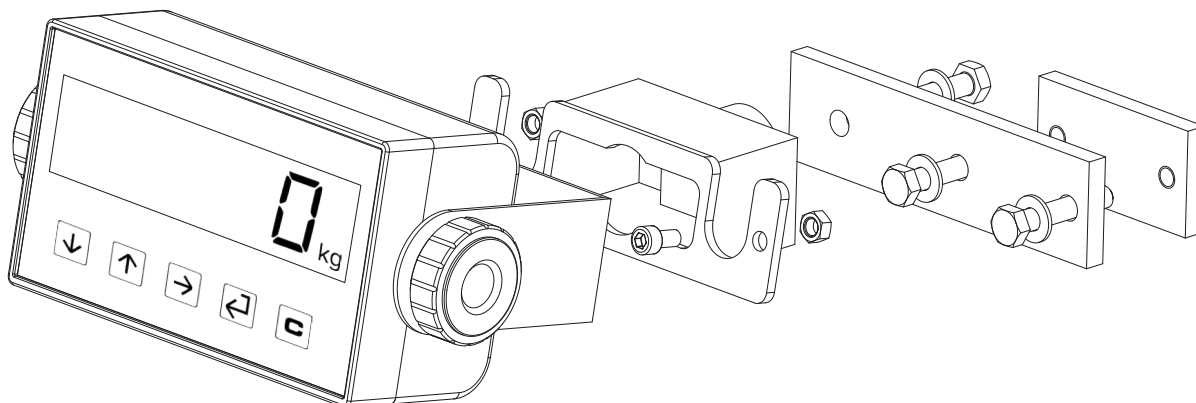

The power cable and the sensor cable are then connected via the two side cable glands.

CONNECTING THE SENSOR TO THE INDICATOR

Connect the cable according to the following standards:

- Disconnect power to the instrument before performing any operation.
- Keep the cable length as short as possible.
- Avoid running the cable near heat sources.
- Make sure that the cable does not get caught in the moving parts of the forklift.
- Connect the cable wires to the indicator terminal block using suitably sized cable lugs.

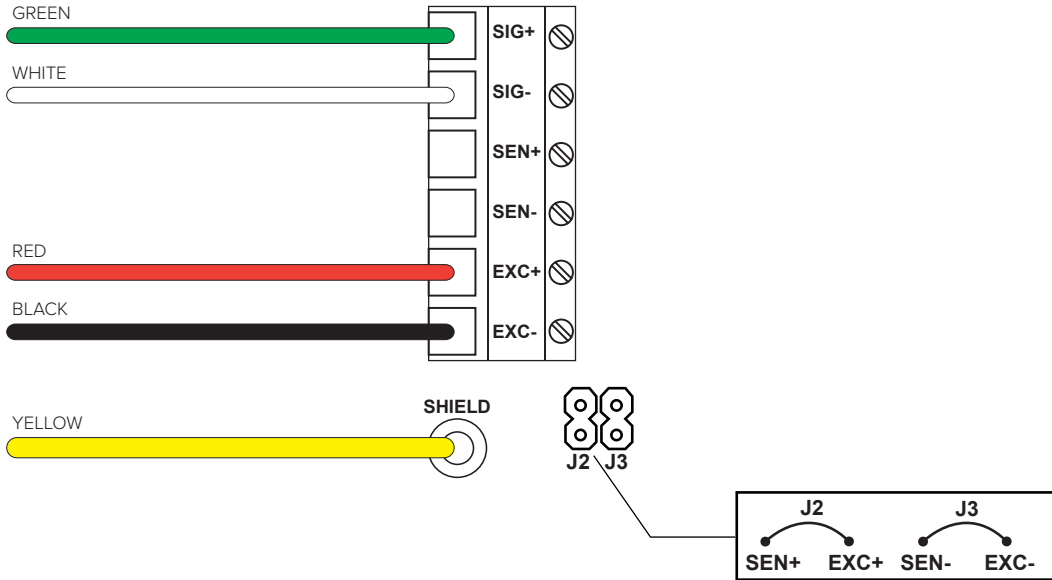

INDICATOR POWER SUPPLY

5 Vdc from forklift through power supply (Dini Argeo supplies two power supply units that can be installed inside the indicator, optional).

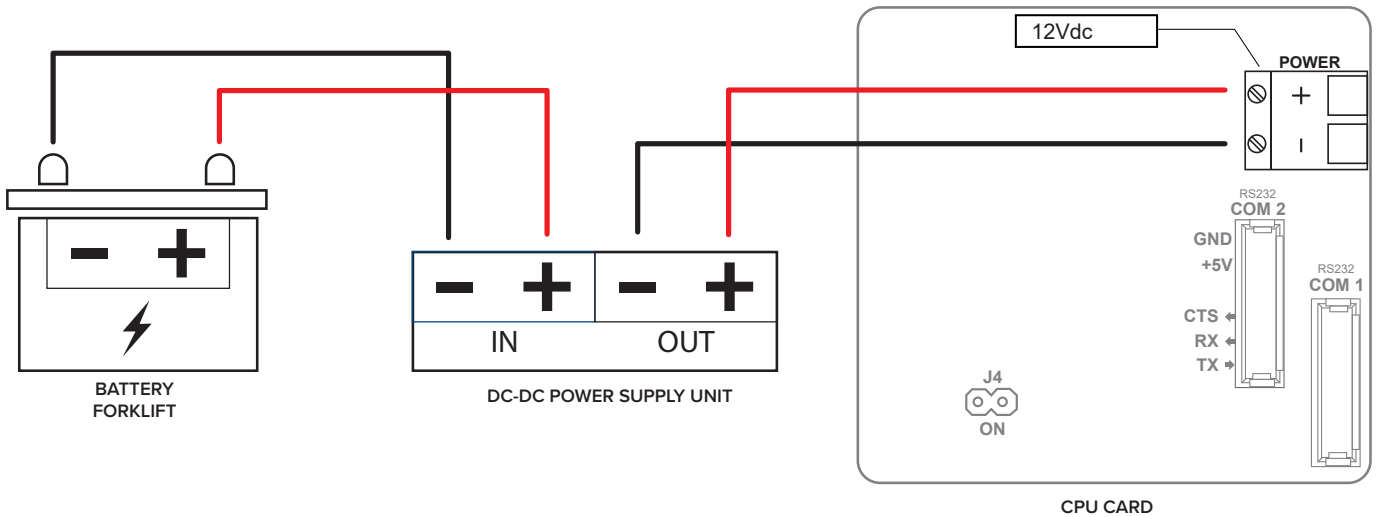

Applying reference stickers

Apply the stickers at a height of at least 50 cm from the ground.

Apply the arrow-shaped sticker to the forklift plate and the rectangular sticker to the upright.

These stickers identify the reference area: perform all weighing operations when the arrowhead is inside the yellow band.

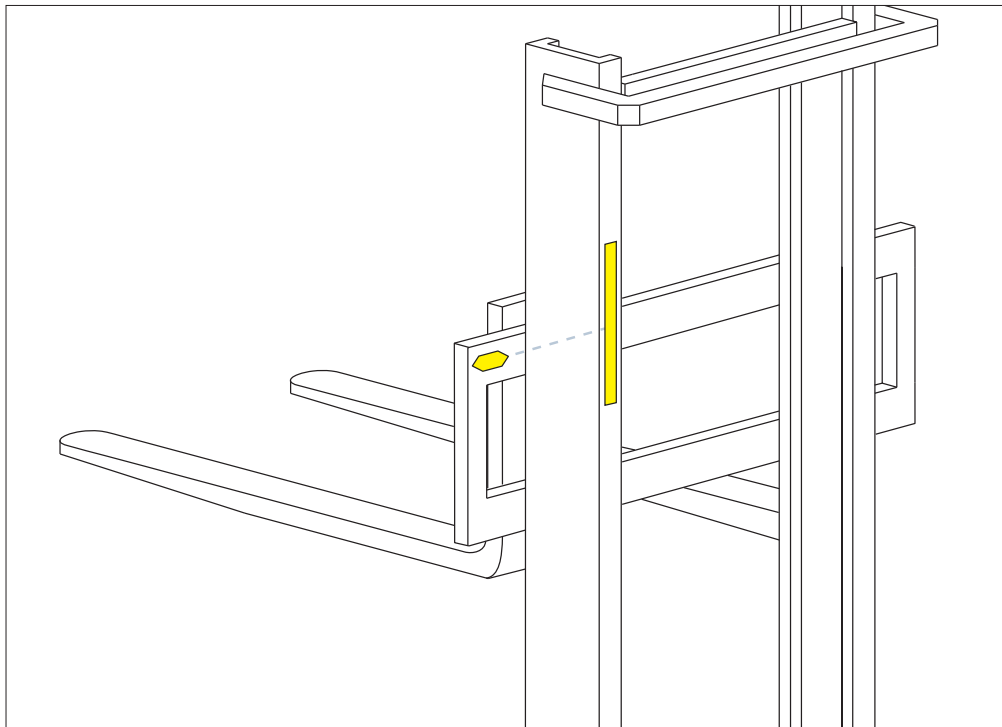

i

The operator must have full visibility of the reference stickers.

Do not apply the stickers at an excessive height: for safety reasons it is not advisable to lift heavy loads above a certain height.

FOREWORD

The system detects the weight based on the pressure trend as a function of time. As each forklift has a different behaviour, it is recommended to use the LTPTOOL PC software to optimise the response speed and accuracy of the weighing system according to the conditions and characteristics of the forklift.

To use the LTPTOOL you need a PC, the **RSCBUSBLTP** connection cable and a weight equal to at least half the capacity of the forklift (ideal condition: sample weight = maximum load capacity).



It is also possible to calibrate the system without using LTPTOOL.

1. PRELIMINARY OPERATIONS

WARMING UP THE HYDRAULIC CIRCUIT OIL

Lift the forks a few times without load. This will warm up the oil to a temperature (and consequently a pressure) more similar to that during subsequent use.

It is recommended to recalibrate the system every 3-4 months to avoid excessive weighing errors due to temperature differences caused by seasonal changes.

REMOVE AIR FROM THE HYDRAULIC CIRCUIT

The presence of air in the hydraulic circuit can worsen the accuracy of the system. To remove it, set the forks to the maximum height twice.



2. GO TO THE PROGRAMMING MENU:

1. Turn off the indicator.

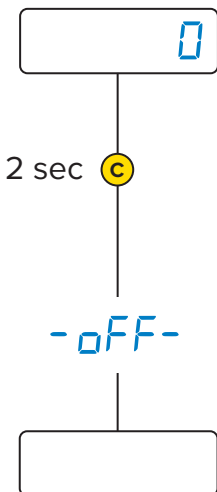

2. Switch on and follow the procedure:

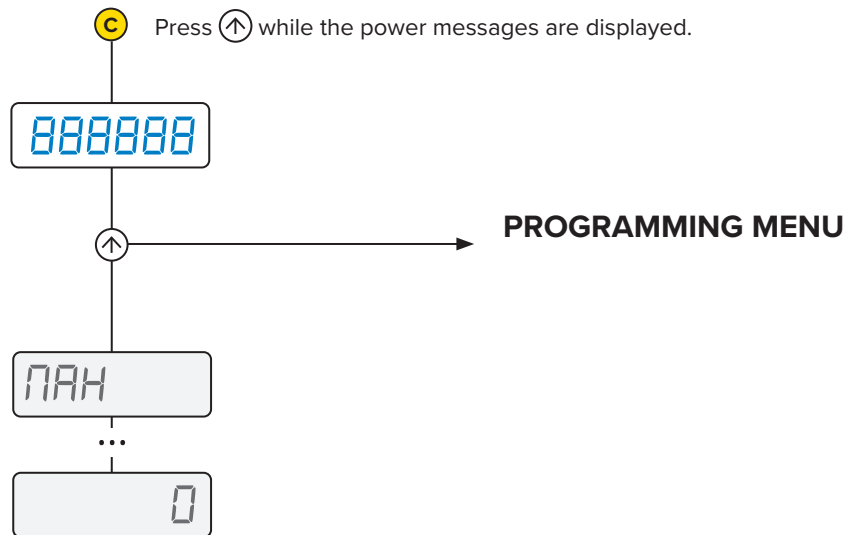

3. SELECT THE [CAL] PARAMETER AND PROCEED WITH THE CALIBRATION



Scroll the main menu with (up arrow) and (down arrow) and enter the [CAL] parameter by pressing (left arrow).

4 OPTIMISING TIMES WITH LTPTOOL

- 4.1 Select the “Settings” tab and select the serial port. Click on “Connect”.
Set the number of up / down cycles (default = 5). By increasing the number of cycles, the procedure becomes longer but the results will be more reliable.

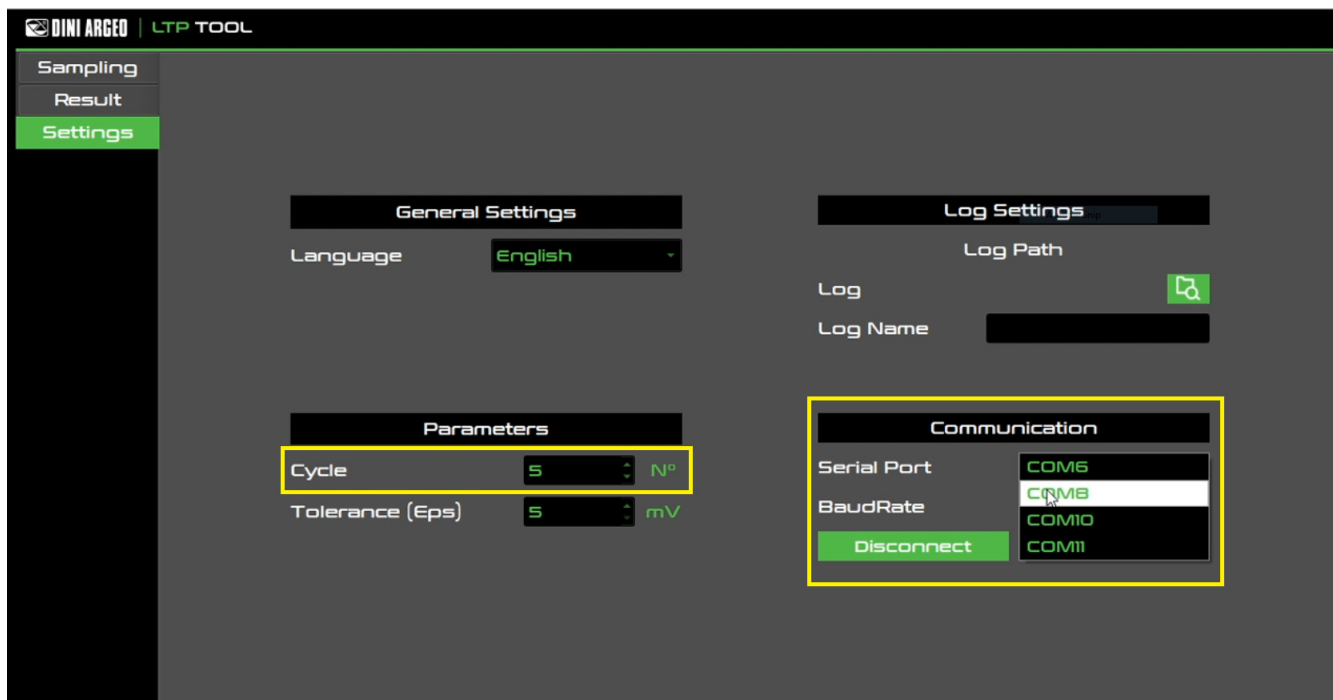

- 4.2 Select the “Sampling” tab.

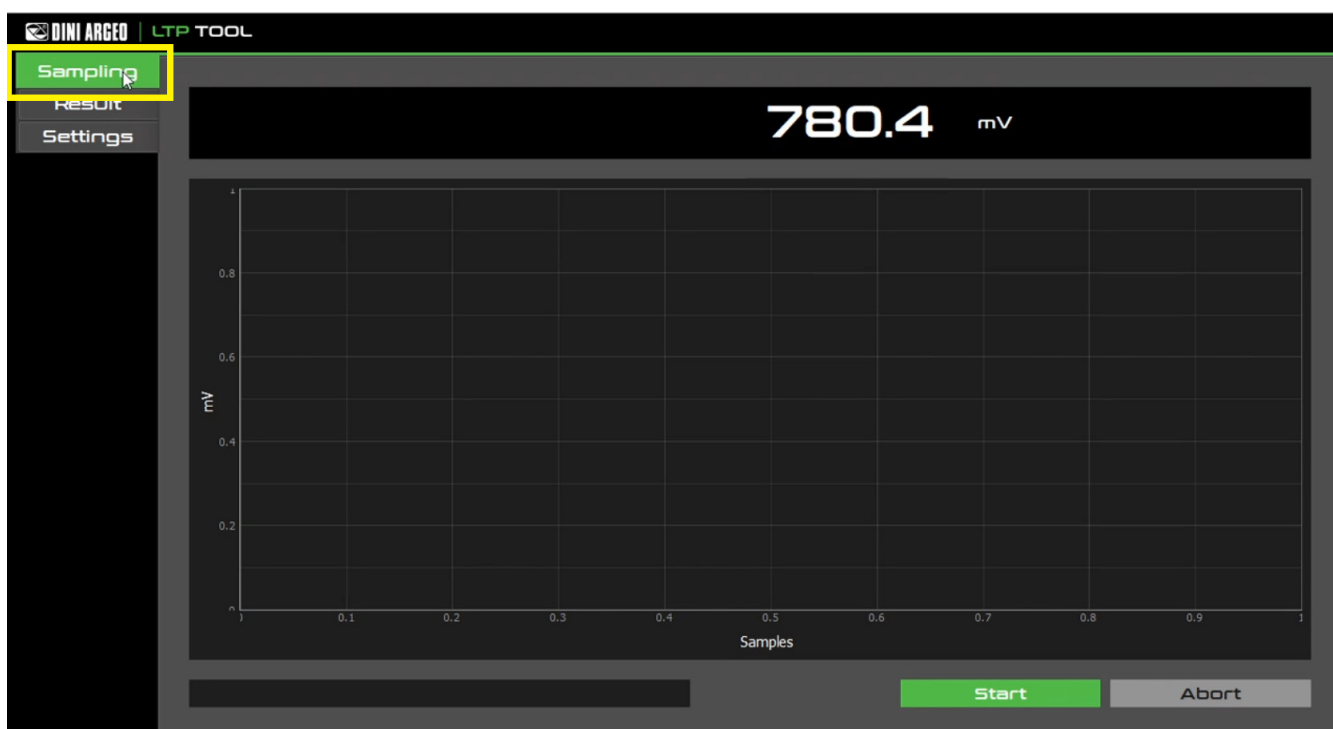

4.3 Click on “Start” and follow the instructions in the box in the bottom left.

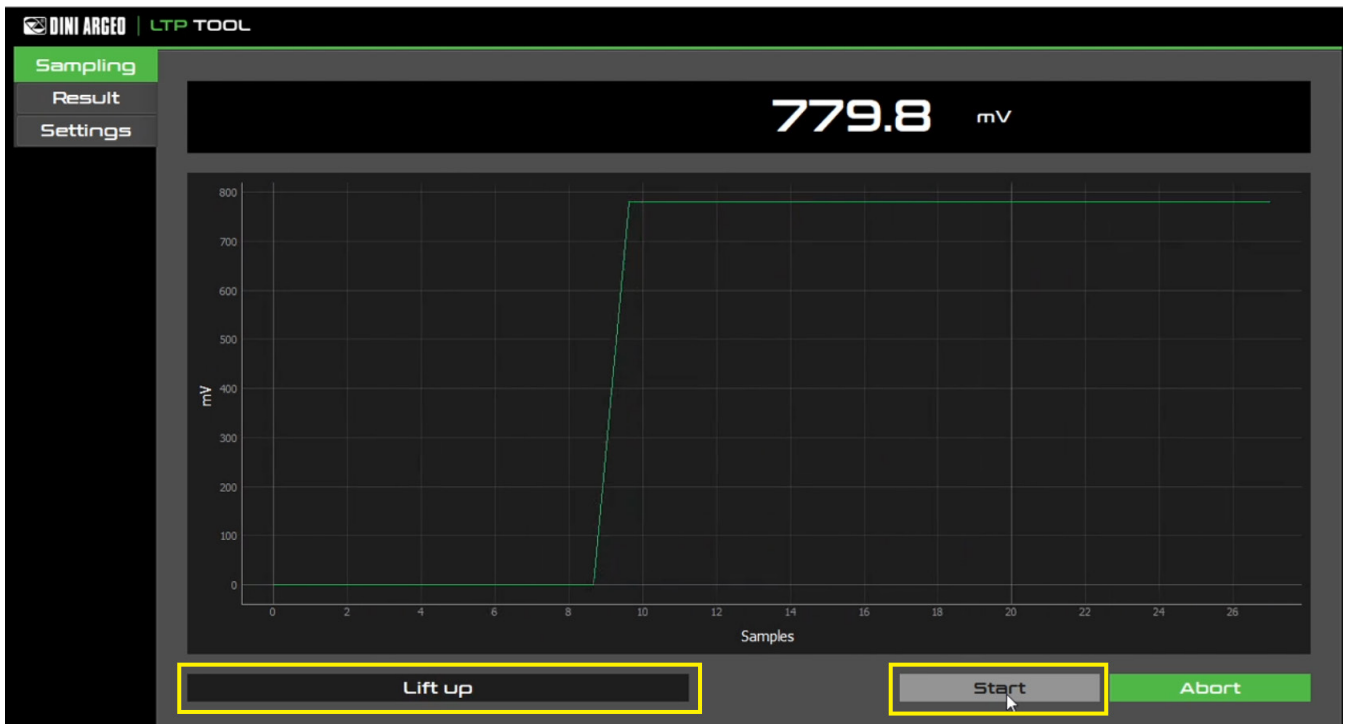

4.4 The times to be used during calibration are shown at the end of the acquisition.



CAL ← d i U ← 1 ÷ 200 ←

Set the resolution and press

How to set the value



CAPAC ← 000000 ←

Set the forklift capacity and press

How to set the value



unLoAd PrESS Pr int

t i n . u P
5 2.0

Place a pallet on the forks

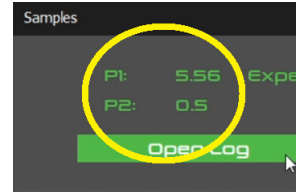

P1 = t i n . u P
P2 = t i n . A U G

t i n . A U G
5 1.0

Set the values calculated by LTP Tool and press

How to set the value



r A I S E . F



Lift the forks

W A I T
0-2-2-2

Wait for the acquisition time

L o W E r . F



Lower the forks

x3

Repeat the lifting / lowering operations of the forks 3 times

o n

* 000000 ←

Enter the calibration weight * and press

How to set the value



r A I S E . F



Lift the forks

W A I T
0-2-2-2

Wait for the acquisition time

L o W E r . F



Lower the forks

x3

Repeat the lifting / lowering operations of the forks 3 times

C A L o n

S t o r E

0

i During the calibration, make the lifting and lowering operations as similar as possible to the subsequent use of the forklift.

***** The highest possible calibration weight must be used for the first calibration (ideal condition: sample weight = maximum capacity).
It will not be possible to acquire a weight greater than the value entered during the first calibration during the next linearisation.

Calibration linearisation

Perform the linearisation after calibration to increase weighing accuracy.

Linearising the calibration means adding calibration points (up to 6). The more calibration points that are added, the more accurate the system will be.



We recommend defining at least 2 linearisation points.

Example:

On a system with a capacity of 2000 kg, assuming an initial calibration with 2000 kg, we recommend adding 3 calibration points at 500 kg, 1000 kg, 1500 kg.

An additional point will need to be added at approximately 250 kg if the system is found to be inaccurate below 500 kg after testing.

HOW TO ADD A CALIBRATION POINT:

1. Lift the weight value you want to acquire (e.g. 500 kg) with the indicator in the weighing state.
The indicator will show the weight and the "HOLD" warning light will appear.
2. Hold  pressed for 5 seconds, The message "E . Error" will appear briefly on the display.
3. Enter the weight value and press .
4. Repeat the operation for each calibration point to be added.

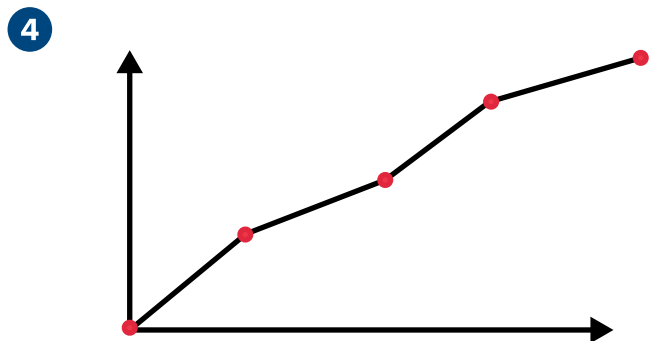
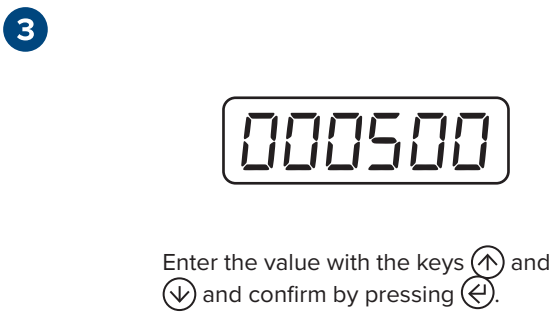
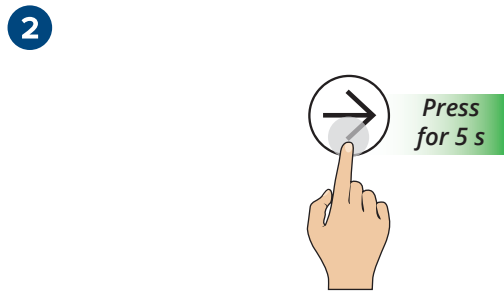
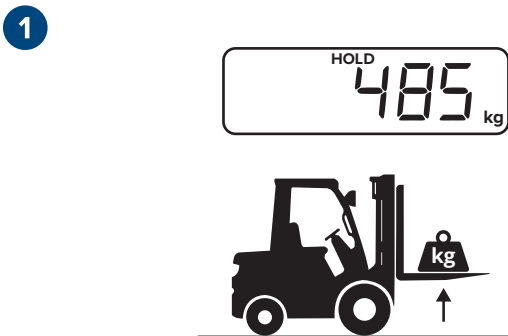

i After 6 linearisation points are reached, adding a new one will overwrite the point with weight value immediately higher than the acquired weight.

It is not possible to add a linearisation point with a weight value higher than the acquired point during the initial calibration (E . Error error).

Additional parameters (for experienced users only)

There are also a number of parameters to further configure the behaviour of the indicator.

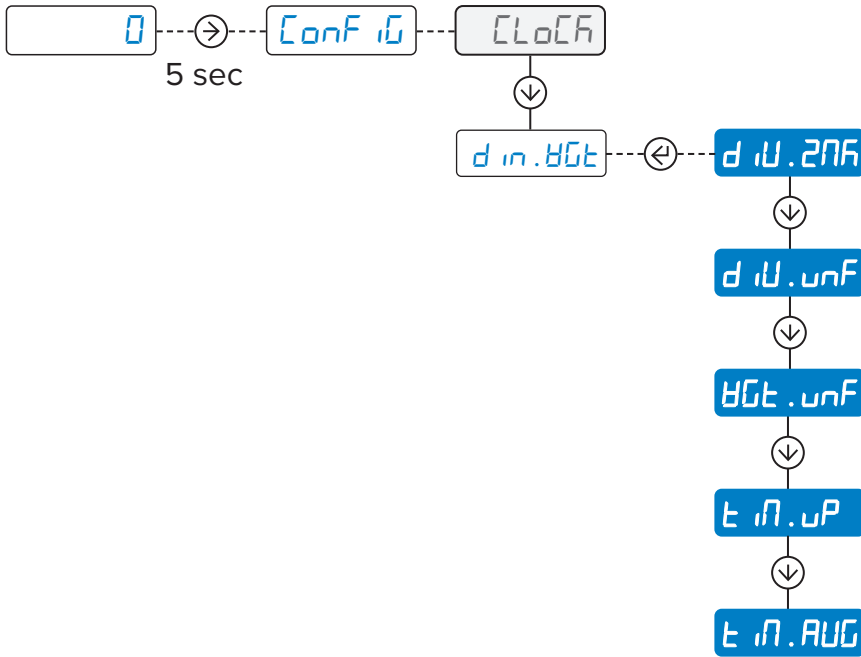

DESCRIPTION OF THE PARAMETERS:

d u. ZNF Number of divisions to mask around zero.

If the displacement of the weight from zero does not exceed the number of divisions set in **d u. ZNF** the indicator will continue to display 0.

Example:

$d u = 20$ kg

$d u. ZNF = 5$

The indicator displays 0 until the weight exceeds 100 kg (or drops below -100 kg).

Increase this value by 5 if the indicator does not show 0 when the forklift is in unloaded fork condition.

d u. unF Number of divisions within which the weight remains in hold state.

If the weight (respect to the last acquired weight) does not exceed the number of divisions set in **d u. unF** the indicator will continue to show the last weight on the display (**HOLD** light on).

Example:

$d u = 20$ kg

$d u. unF = 2$

After the indicator displays 500 kg, the weight must exceed 540 kg (or drop below 460 kg) to unlock and make a new measurement.

Increase this value by 2 if the indicator returns to the weighing state (dashes) a few seconds after displaying the weight.

HGT. unF Fork weight value.

On forklifts, lowering the forks all the way to the ground would result in a negative weight of approximately the weight of the forks. Setting the approximate weight value of the forks ensures that the indicator will display 0 value even when the weight is negative and that the system will start weighing when the set threshold is exceeded.

t n. uP Waiting time between end of fork ascent and start of acquisition

Used to delay the acquisition of the weighing.

t n. AVG Weight acquisition time.

The weight is obtained by averaging the values acquired during the set time.

i Access to the menu **dyn. HGT** can be locked using a password. See the **P n. u5E** parameter.

CAL	Calibration.....	15
↓		
O.CAL	Zeroring the pre-tare (zero calibration).....	23
↓		
CAL AdU	Advanced calibration.....	23
↓		
SERIAL	Configuration of the serial ports.....	26
↓		
LAYout	Print customisation	31
↓		
SCrEEen	Adjusting the display.....	39
↓		
AutoFF	Auto switch-off.....	40
↓		
SCr.SAV	Screen-saver	40
↓		
rESEt	Factory configuration reset	40
↓		
dIAG	Diagnostics	41
↓		
AdVAnC	Advanced.....	42

 Parameter visible only under certain conditions.

Enter	Browse	Save and exit
1. Off	=	 Page 15
2. On	=	
3.	=	
Page 15	=	

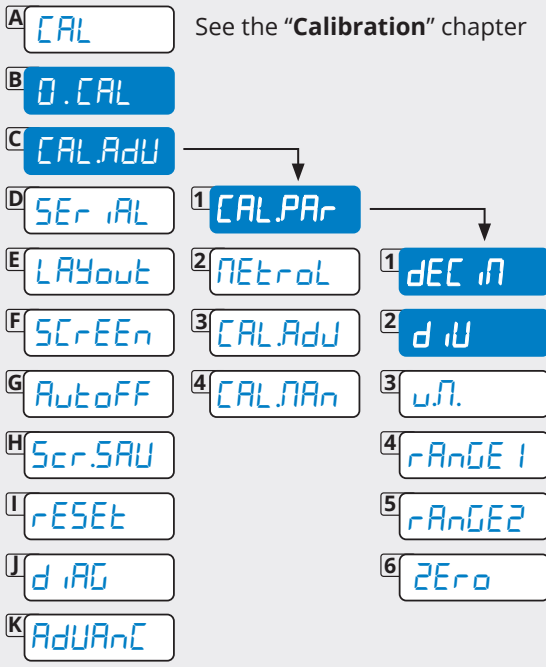

D.CAL Zeroring the pre-tare

Acquisition of the zero point

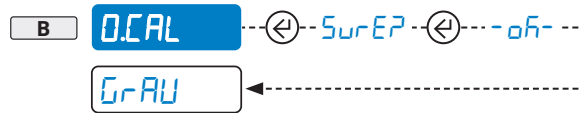

CAL .AdU Advanced calibration

CAL .PAr Calibration parameters

Configuration of the decimal point (0...3)

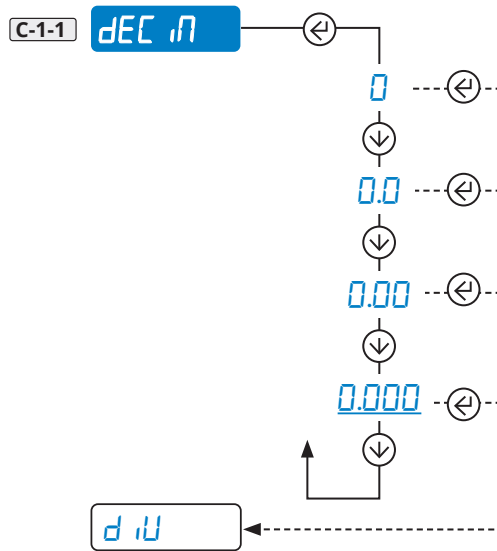

Reading division

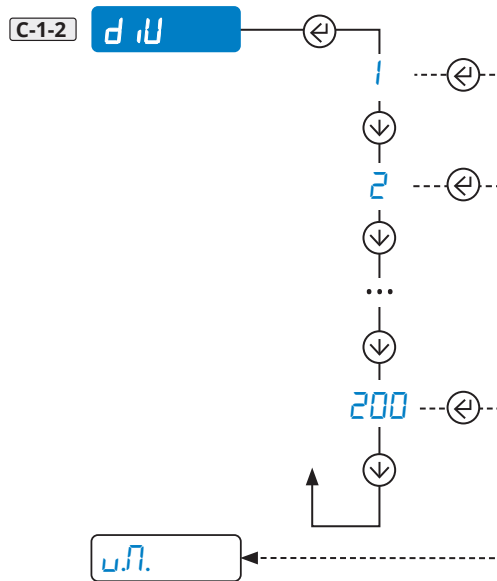

Enter	Browse	Save and exit
1. Off	=	
2. On	=	
3.	=	
Page 15	=	
		Page 15

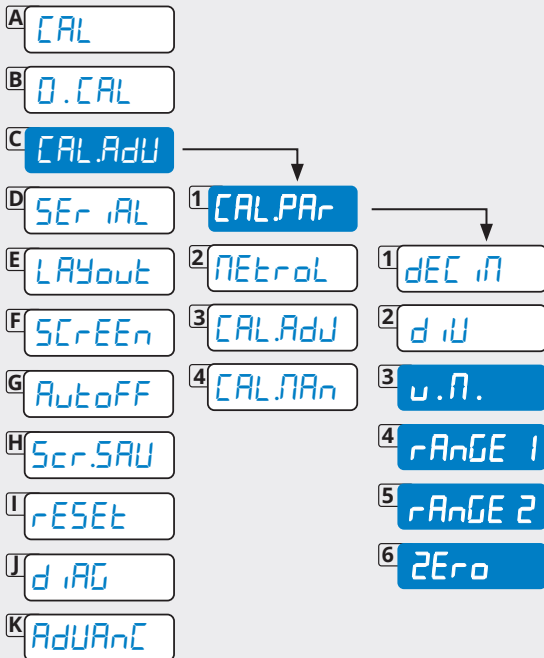

Unit of measure

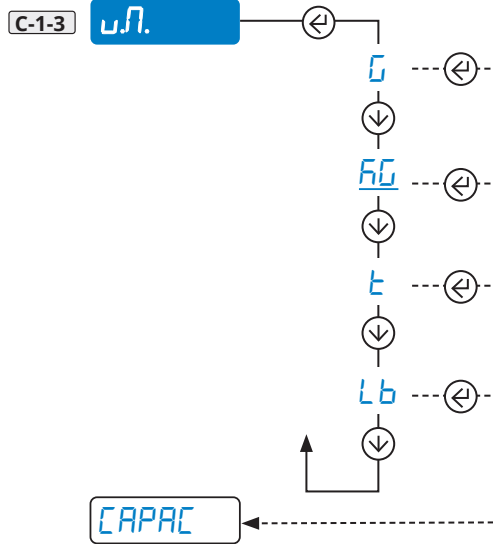

Scale capacity. Set Max or Range 1 (Max range = 800.000)

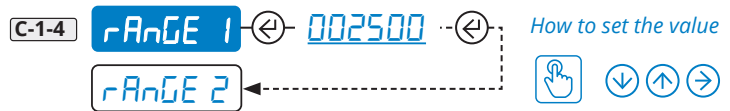

Range 2

For multirange scales, set the second weighing range.



Example of multirange configuration at 1000/2500 kg, division 10/20 kg.

Set:

- dEC i = 0
- d iU = 10
- rAnGE 1 = 1000
- rAnGE 2 = 2500

Zero

Start of the advanced calibration procedure:

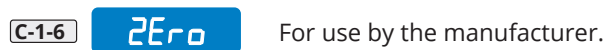

Enter	Browse	Save and exit
1. Off	=	
2. On	=	
3.	=	
Page 15	=	
		Page 15

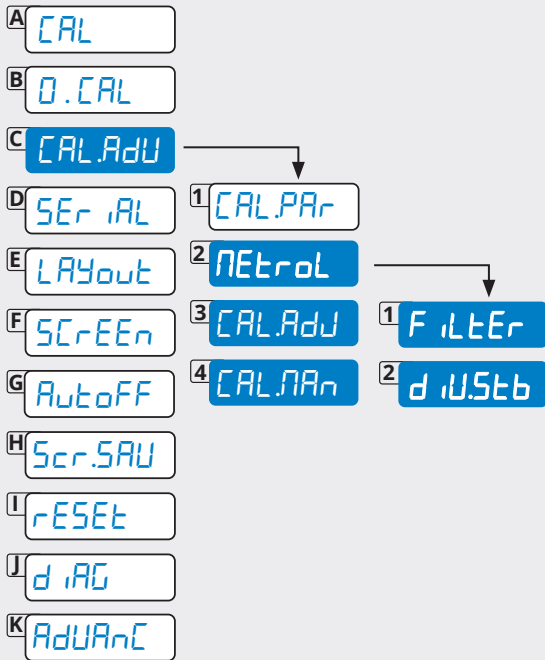

Filter configuration

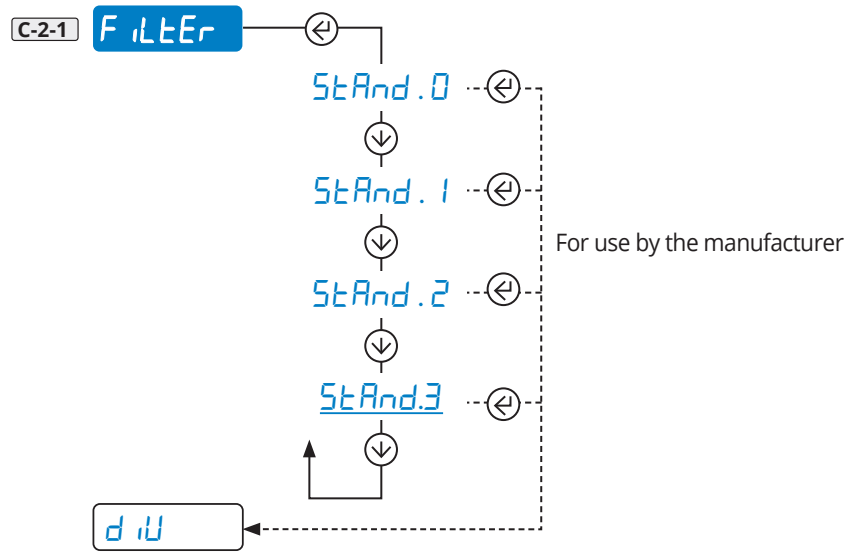

Stability detection sensitivity

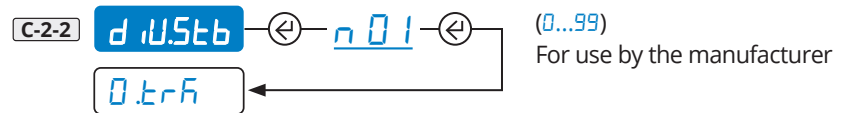

Re-acquisition / change of the calibration points in memory.

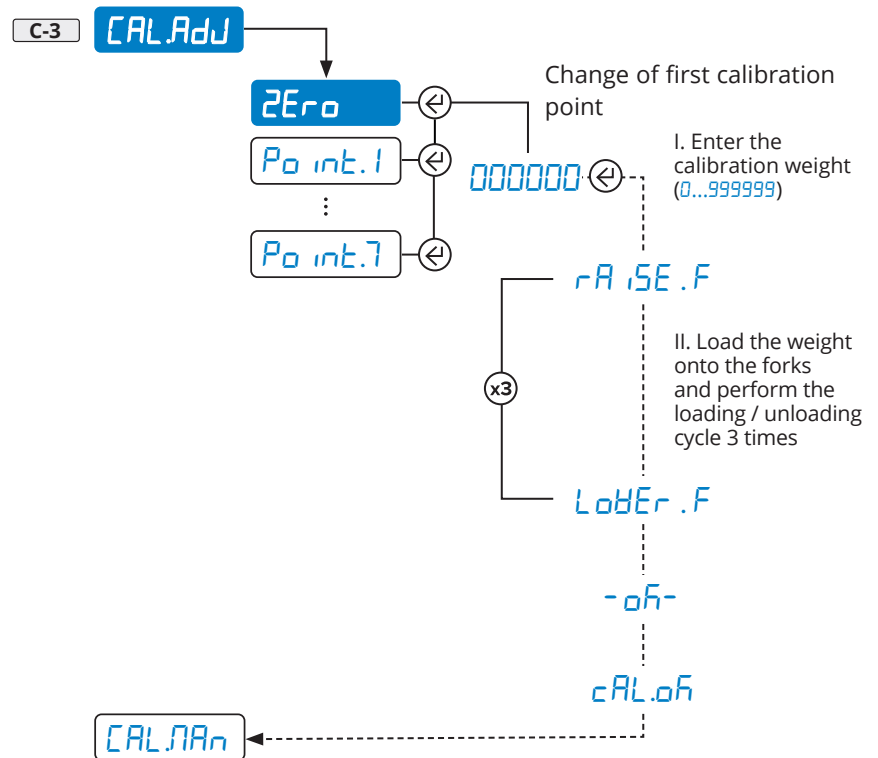

Repeat the operation for each calibration point.

C-4 [CAL.nAn] For use by the manufacturer.

Enter	Browse	Save and exit
1. Off	=	
2. On	=	
3.	=	
Page 15	=	
		Page 15

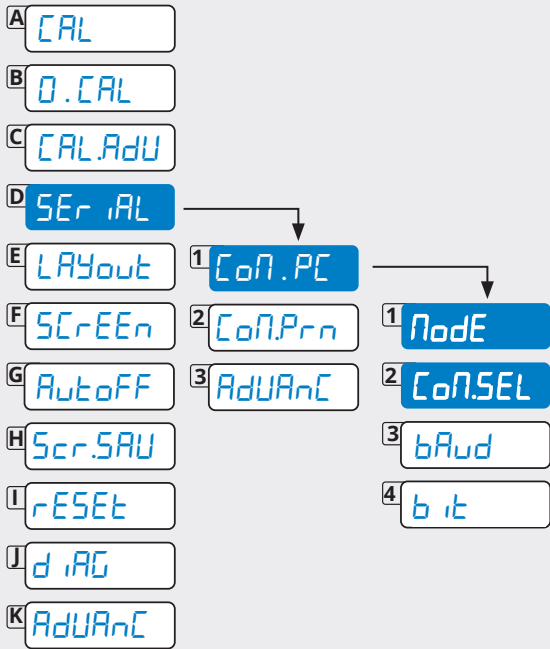

SERIAL Configuration of the serial ports

CoN.PC Communication with PC, PLC or Repeater

Selection of the communication mode

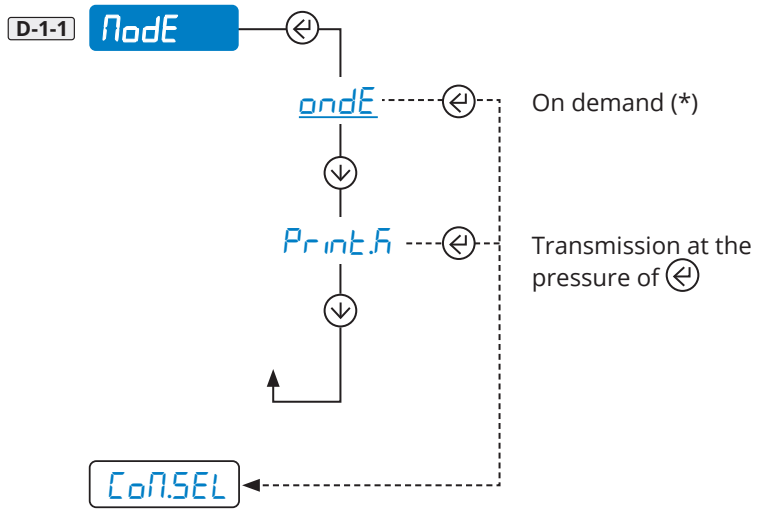

* For communication strings and commands see page 43.

For string selection, see step **D-3-1**.

COM port selection for PC / PLC connection

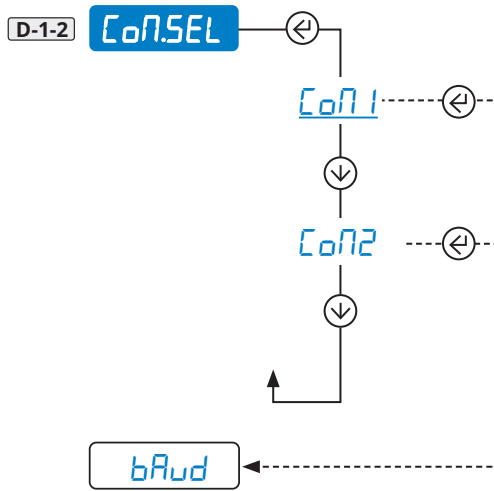

MENU

Enter	Browse	Save and exit
1. Off	=	
2. On	=	
3.	=	
Page 15	=	

A	CAL	
B	0.CAL	
C	CALAdU	
D	SEr iAL	
E	LAYout	1 CoN.PC
F	SCrEEEn	2 CoN.Prn
G	AutoFF	3 AdUAnC
H	Scr.SAU	4 b it
I	rESEt	1 Node
J	d iAG	2 CoN.SEL
K	AdUAnC	3 bAud
		4 b it

Communication speed (Baud rate)

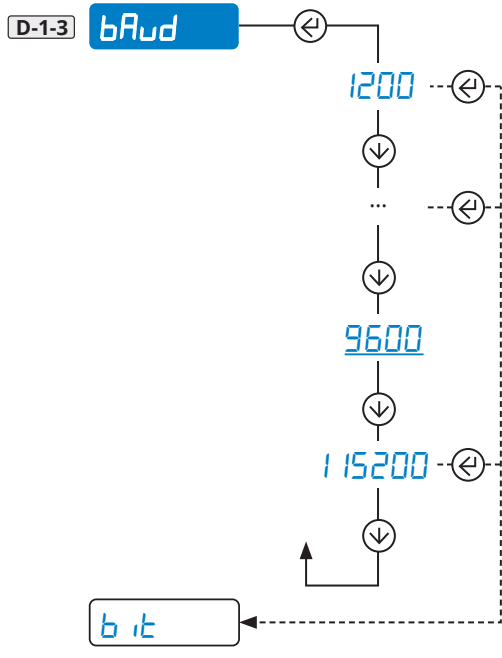

Configuration of the serial protocol

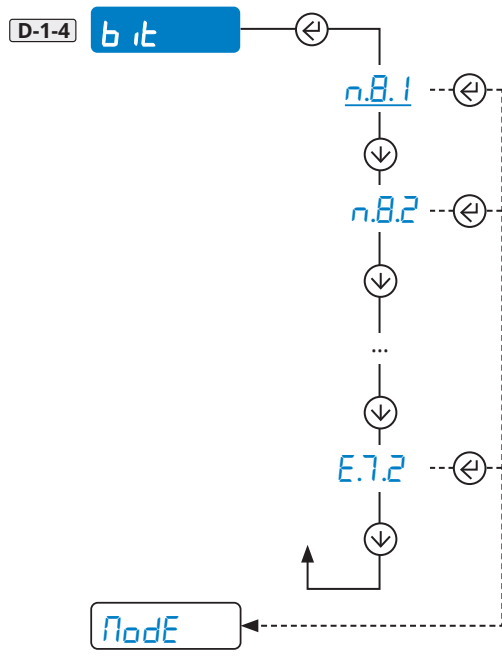

Enter	Browse	Save and exit
1. Off	↑ =	 <i>Page 15</i>
2. On	↓ =	
3.	→ =	
<i>Page 15</i>	← =	

- A
- B
- C
- D
 - 1
 - 2
 - 1
 - 2
 - 3
- E
- F
- G
- H
- I
- J
- K

Communication speed (Baud rate)

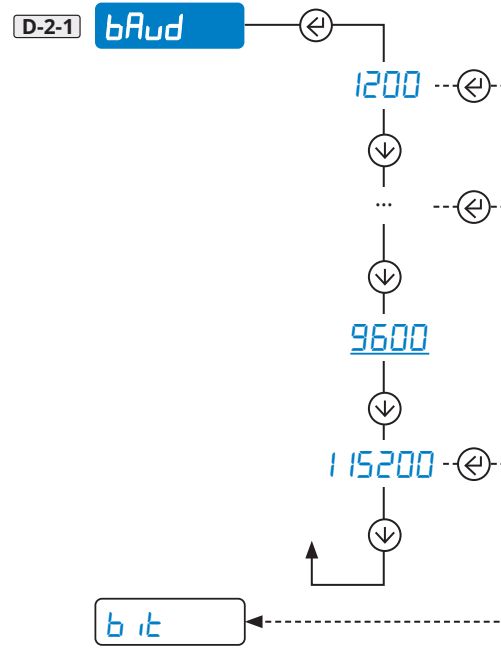

Configuration of the serial protocol

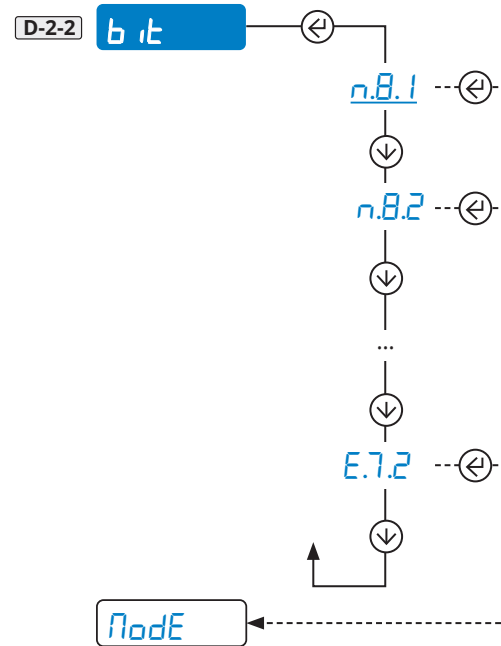

MENU

Enter	Browse	Save and exit
1. Off	↑ =	
2. On	↓ =	
3.	→ =	
Page 15	← =	

- A CAL
- B 0.CAL
- C CAL.AdU
- D SERIAL
 - 1 CoN.PC
 - 2 CoN.Prn
 - 3 AdVAnC
 - 1 bAud
 - 2 b it
 - 3 **CtS**
- E LAYout
- F SCrEEen
- G AutoFF
- H Scr.SAU
- I rESEt
- J d iAG
- K AdVAnC

Printer control signal

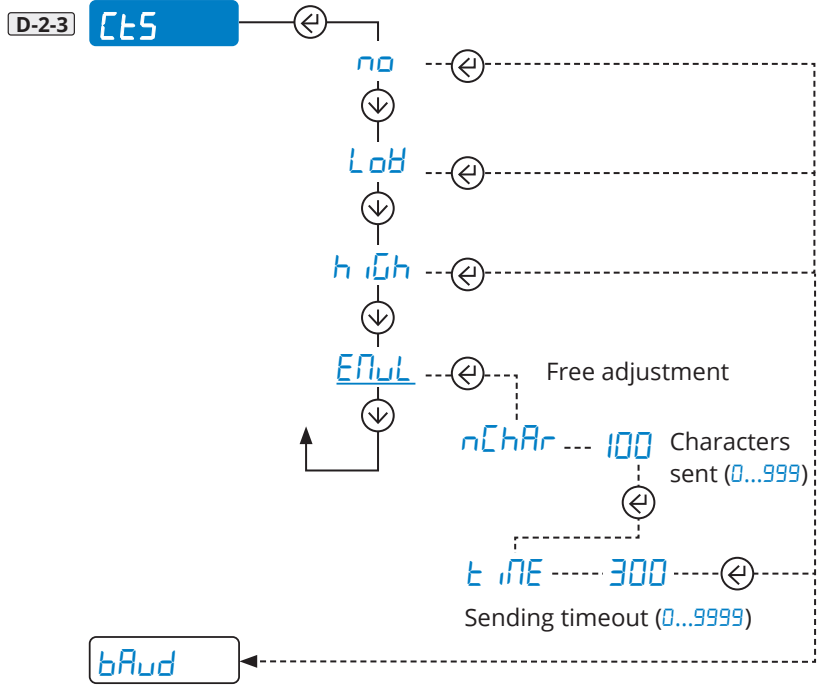

Enter	Browse	Save and exit
1. Off	=	
2. On	=	
3.	=	
=		
Page 15		Page 15

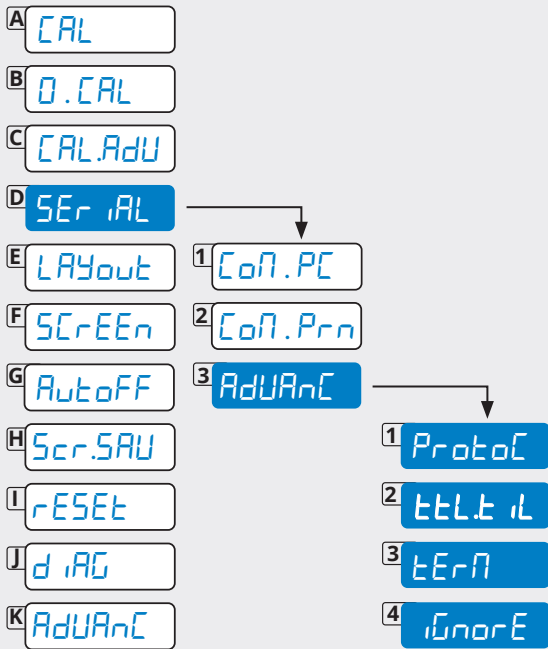

Communication protocol

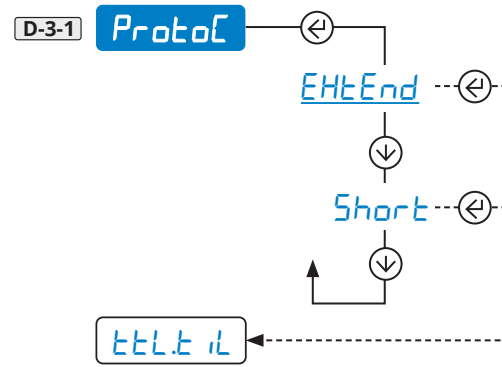

For communication strings and commands see page 43.

TTL port (for use by the manufacturer)

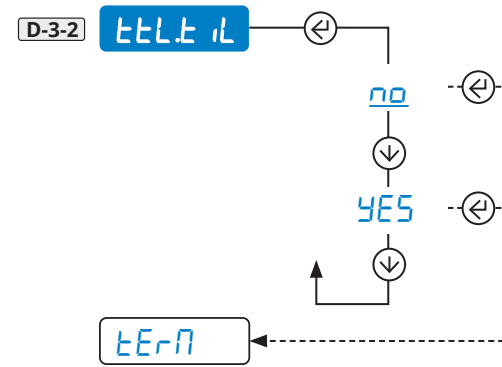



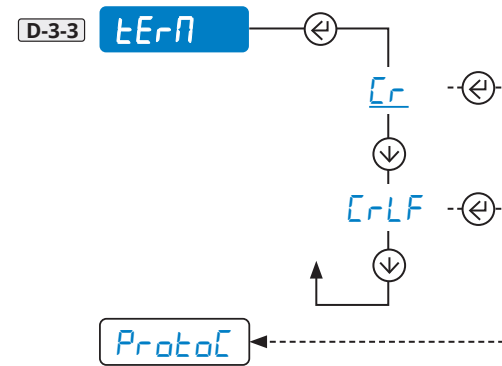



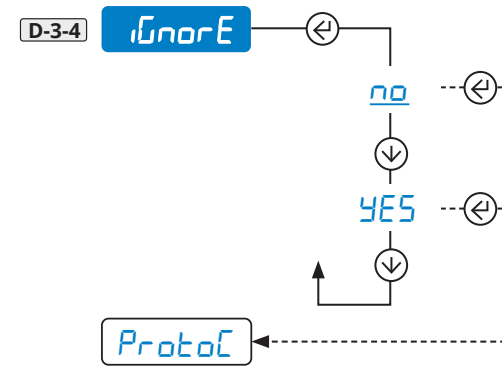







Closing character of each print line



Ignore unknown commands



When an unknown command is sent:
 - Selecting NO will result in the response "ERR04".
 - Selecting YES ignores the command (no response).

Enter	Browse	Save and exit
1. Off 	 = 	  Page 15
2. On 	 = 	
3. 	 = 	
 Page 15	 = 	
		

- A
- B
- C
- D
- E
 - 1
 - 2
 - 3
 - 4
 - 5
 - 6
 - 7
 - 8
 - 9
 - 10
 - 11
 - 12
 - 13
 - 14
 - 15
 - 16

Parameters for receipt / label mode

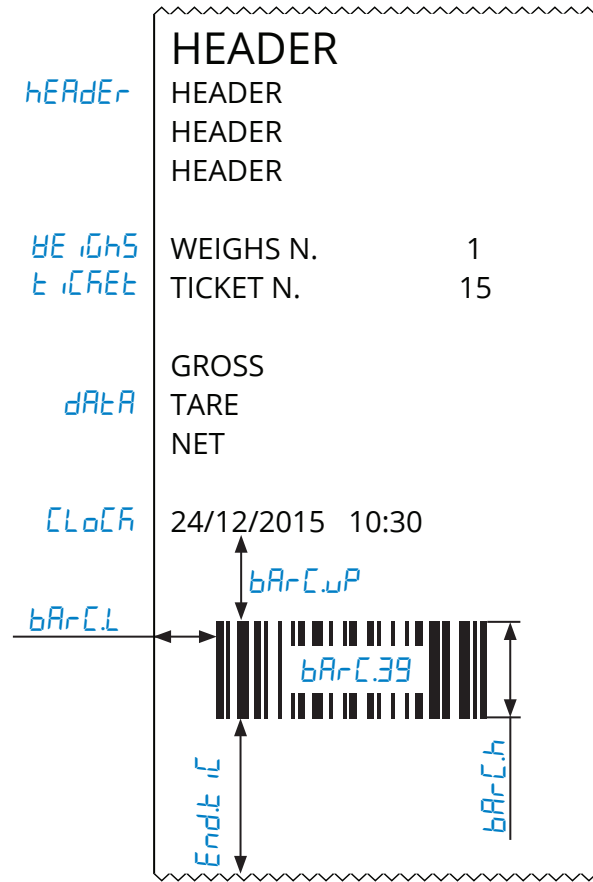

MENU

Enter	Browse	Save and exit
1. Off	=	
2. On	=	Page 15
3.	=	
Page 15	=	

- A CAL
- B 0.CAL
- C CALAdU
- D SEr iAL
- E **LAYout**
 - 1 LANG
 - 2 ChAr
 - 3 hEADer
 - 1 ChAr 1
 - 2 ChAr 2
 - 4 dAtA
 - 5 HE iGHS
 - 6 t iCREt
 - 7 CLoCh
 - 8 bArCLP
 - 9 bArCLP
 - 10 bArCL
 - 11 bArCh
 - 12 bArCdt
 - 13 CoP iES
 - 14 Endt iC
 - 15 bL inE
 - 16 tEst
- F SCrEEr
- G AutoFF
- H SCr.SAU
- I rESEt
- J d iAG
- K AdVAnC

Setting of the print language (iCAL, EnGL, dEuT, FrAn, ESPr, Ch inES)

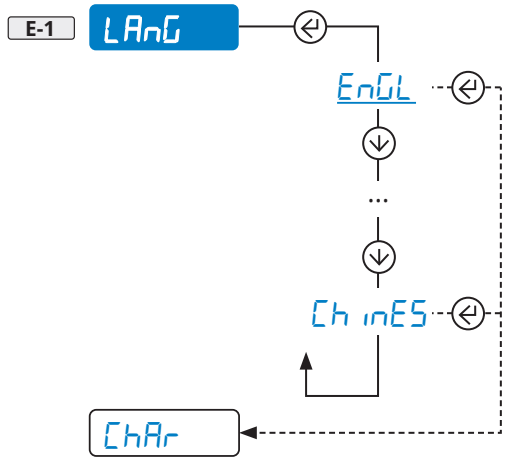

Font dimensions

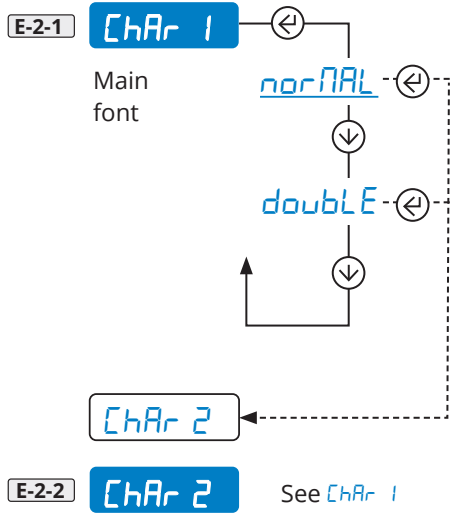

hEADer Print header

Enables header printing

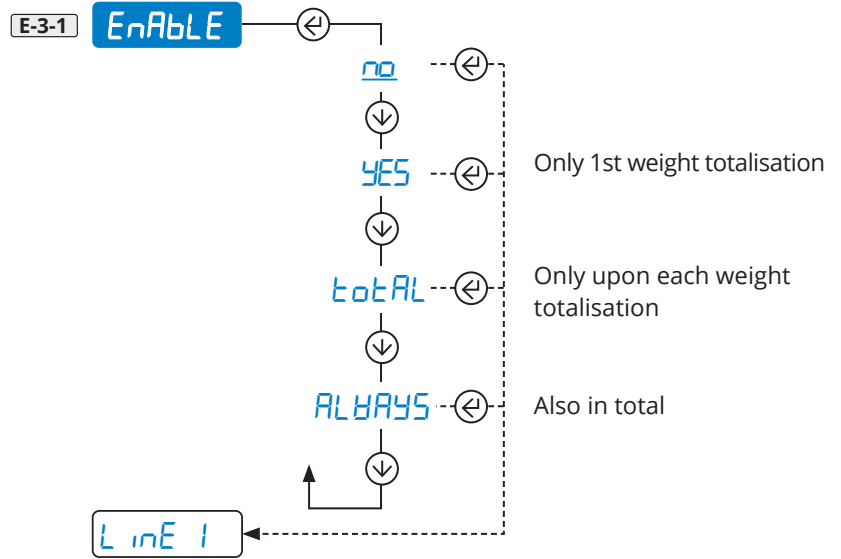

Contents of the header lines

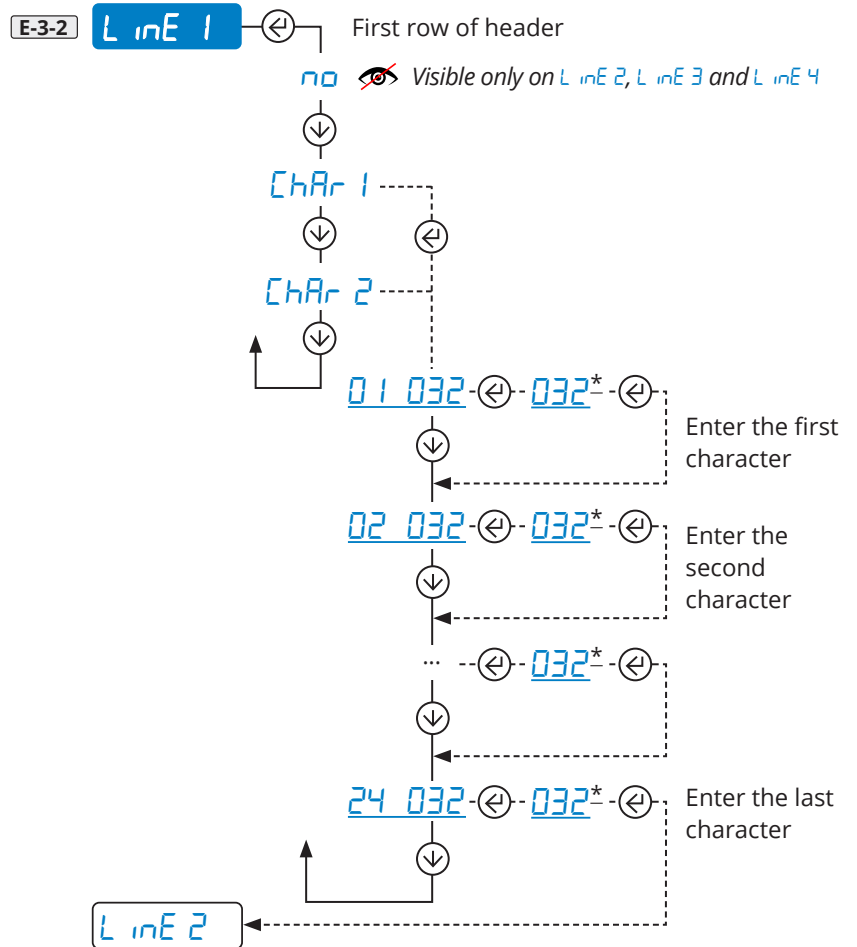

How to set the value



i Repeat the operation to program LINE 2, LINE 3 and LINE 4. Select no to disable them.

Enter	Browse	Save and exit
1. Off	↑ =	 i Page 15
2. On	↓ =	
3.	→ =	
i Page 15	← =	
	← =	

A	CAL		
B	0.CAL		
C	CALADU		
D	SERIAL		
E	LAYout		
F	SCREEN	1	LANG
G	AutoOFF	2	CHAR
H	Scr.SAV	3	hEADer
I	rESEt	4	datA
J	diag	5	WEIGHs
K	ADVAnC	6	tICREt
		7	CLoCh
		8	bARCL39
		9	bARCLWP
		10	bARCL
		11	bARCh
		12	bARCLdt
		13	CoPIES
		14	EndtIC
		15	bLINE
		16	tEST

MENU

Enter	Browse	Save and exit
1. Off	=	
2. On	=	
3.	=	
Page 15	=	
	=	

- A CAL
- B 0.CAL
- C CAL ADU
- D SERIAL
- E **LAYOUT**
 - 1 LANG
 - 2 CHAR
 - 3 **HEADER**
 - 1 **ENABLE**
 - 2 **LINE 1**
 - 3 **LINE 2**
 - 4 **LINE 3**
 - 5 **LINE 4**
 - 4 DATA
 - 5 WEIGHS
 - 6 CREATE
 - 7 CLOFF
 - 8 BARCL39
 - 9 BARCLWP
 - 10 BARCL
 - 11 BARCLh
 - 12 BARCLdt
 - 13 COPIES
 - 14 Endt CL
 - 15 b.LINE
 - 16 TEST
- F SCREEN
- G AutoOFF
- H Scr.SAV
- I rESEt
- J d iAG
- K AdVAnC

How to print / delete the row being programmed

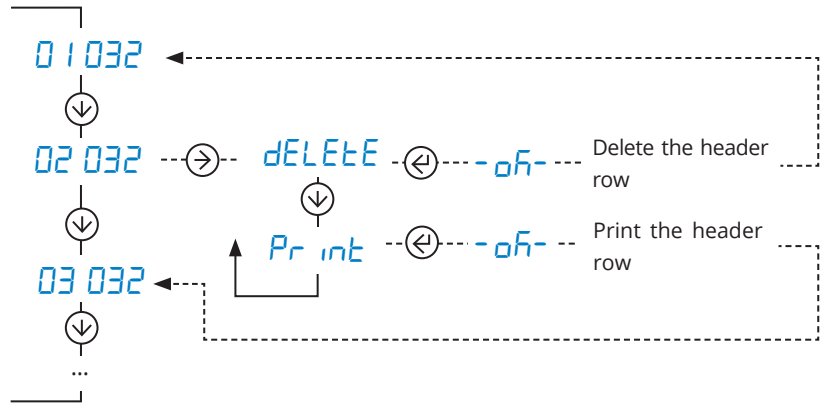

Programming example

List of characters

(*)

32		47	/	62	>	77	M	92	\	107	k	122	z
33	!	48	0	63	?	78	N	93]	108	l	123	{
34	"	49	1	64	@	79	O	94	^	109	m	124	
35	#	50	2	65	A	80	P	95	_	110	n	125	}
36	\$	51	3	66	B	81	Q	96	'	111	o	126	~
37	%	52	4	67	C	82	R	97	a	112	p		
38	&	53	5	68	D	83	S	98	b	113	q		
39	'	54	6	69	E	84	T	99	c	114	r		
40	(55	7	70	F	85	U	100	d	115	s		
41)	56	8	71	G	86	V	101	e	116	t		
42	*	57	9	72	H	87	W	102	f	117	u		
43	+	58	:	73	I	88	X	103	g	118	v		
44	,	59	;	74	J	89	Y	104	h	119	w		
45	-	60	<	75	K	90	Z	105	i	120	x		
46	.	61	=	76	L	91	[106	j	121	y		

Enter	Browse	Save and exit
1. Off	=	
2. On	=	
3.	=	
Page 15	=	

- A
- B
- C
- D
- E
- F
 - 1
- G
 - 2
- H
 - 3
- I
 - 4
- J
 - 5
- K
 - 6
 - 7
 - 8
 - 9
 - 10
 - 11
 - 12
 - 13
 - 14
 - 15
 - 16

Selection of the weight data

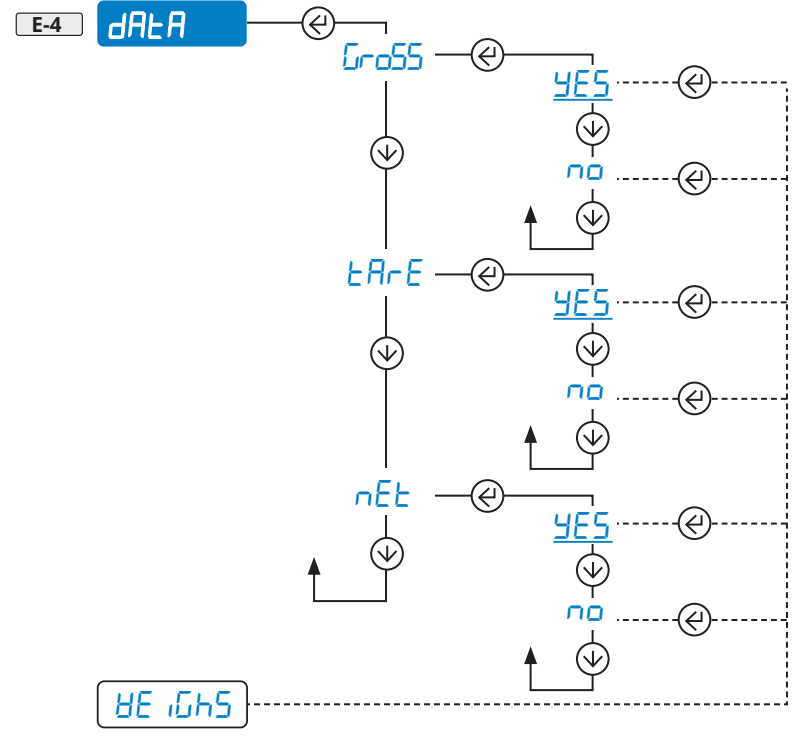

Progressive weighed

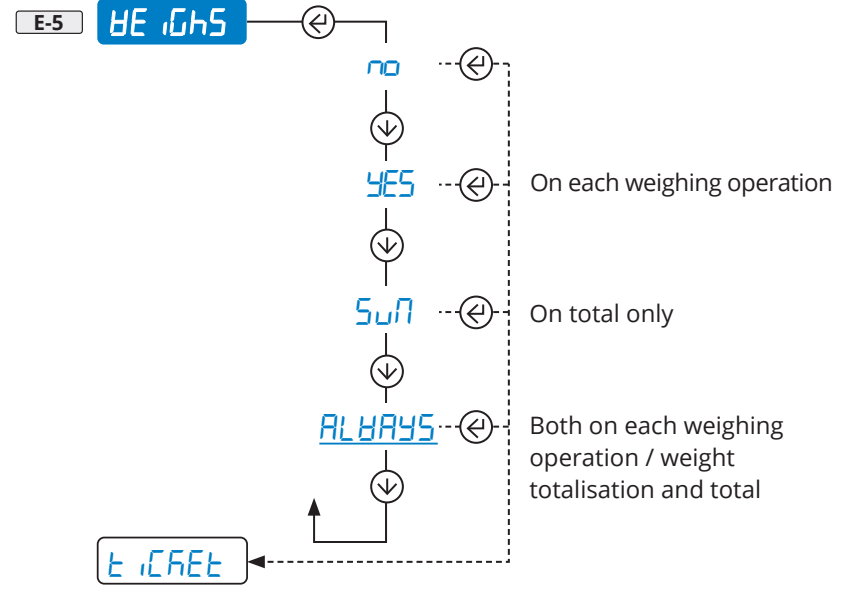

Receipt / label progressive

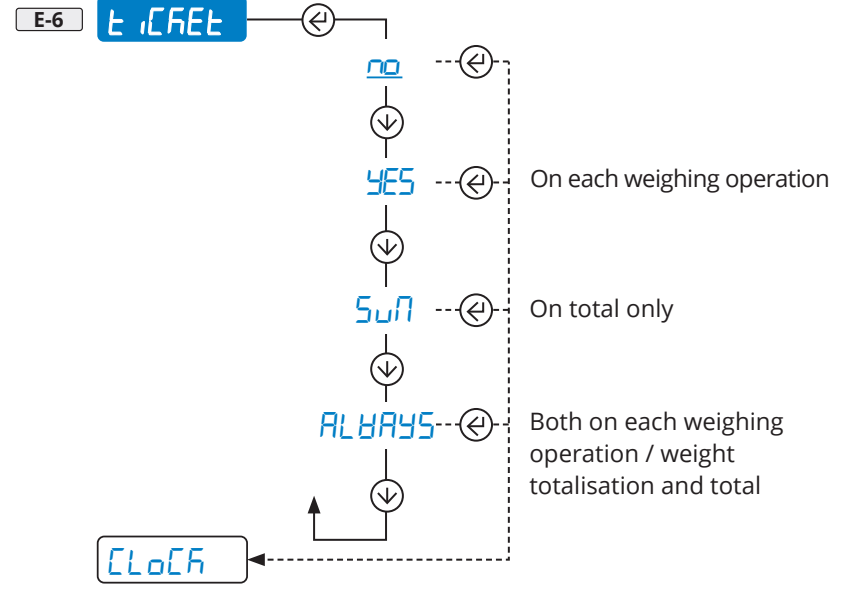

MENU

Enter	Browse	Save and exit
1. Off	=	
2. On	=	
3.	=	
Page 15	=	

- A CAL
- B 0.CAL
- C CAL ADU
- D SERIAL
- E **LAYOUT**
 - 1 LANG
 - 2 CHAR
 - 3 HEADER
 - 4 DATA
 - 5 WEIGHS
 - 6 TARET
 - 7 **CLOCK**
 - 8 **BARC.39**
 - 9 **BARC.WP**
 - 10 **BARC.L**
 - 11 **BARC.h**
 - 12 **BARC.dt**
 - 13 **COPIES**
 - 14 **Endt C**
 - 15 **bl inE**
 - 16 **TEST**

Date and time

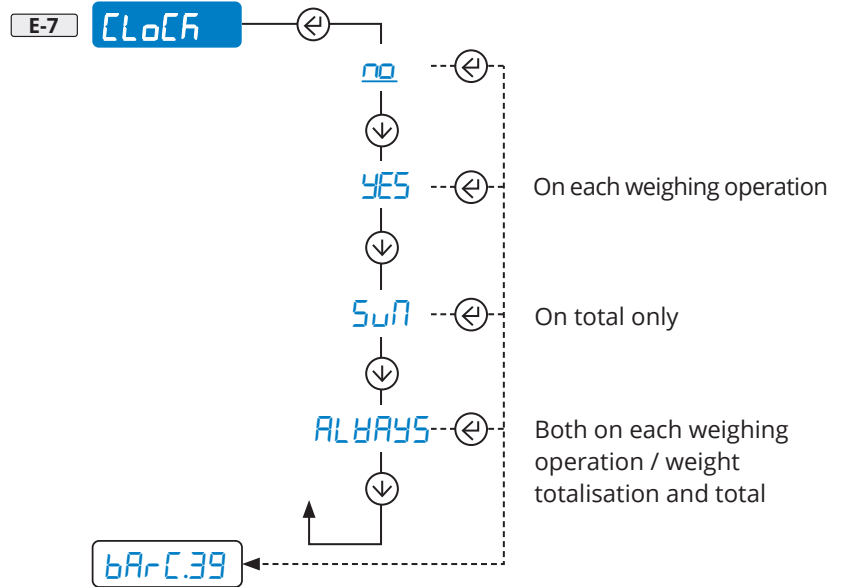

Bar code 39

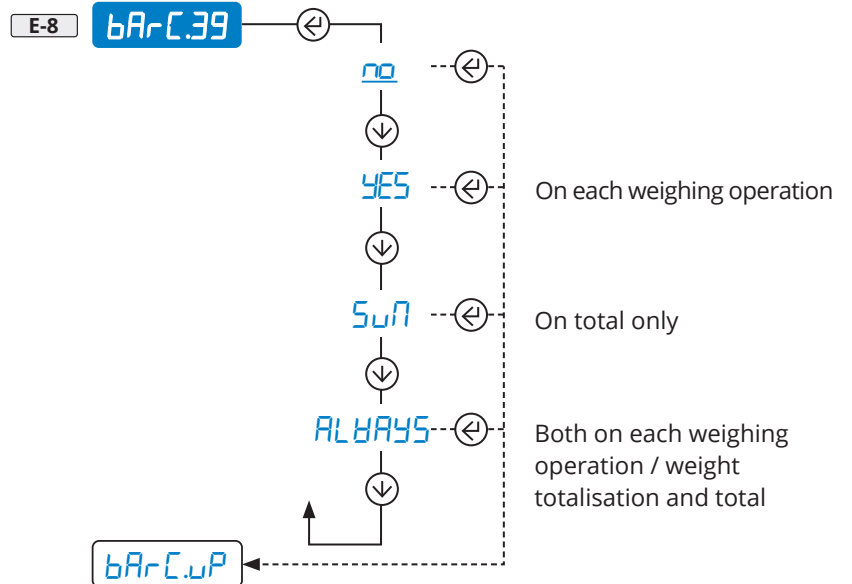

Barcode top margin (mm)

Visible only if **bARc.39** (E-8) is active

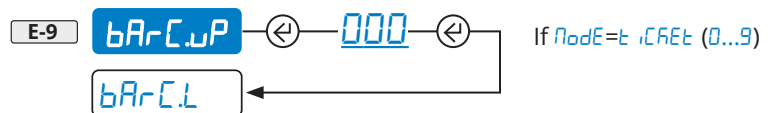

Barcode left margin (mm)

Visible only if **bARc.39** (E-8) is active

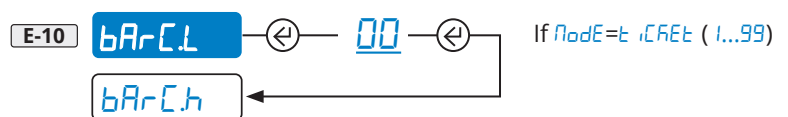

Barcode height (mm)

Visible only if **bARc.39** (E-8) is active

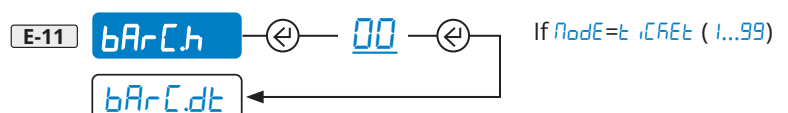

Enter	Browse	Save and exit
1. Off	=	
2. On	=	
3.	=	
	=	
Page 15	Page 15	

- A CAL
- B 0.CAL
- C CALADU
- D SERIAL
- E **LAYOUT**
 - 1 LANG
 - 2 CHAR
 - 3 HEADER
 - 4 DATA
 - 5 WEIGHTS
 - 6 TARET
 - 7 CLOFF
 - 8 **bARC39**
 - 9 **bARCWP**
 - 10 **bARCL**
 - 11 **bARCh**
 - 12 **bARCdt**
 - 13 **CoPIES**
 - 14 **Endt iC**
 - 15 **bLi nE**
 - 16 tEST

Selection of the weight data

Visible only if **bARC39** (E-8) is active

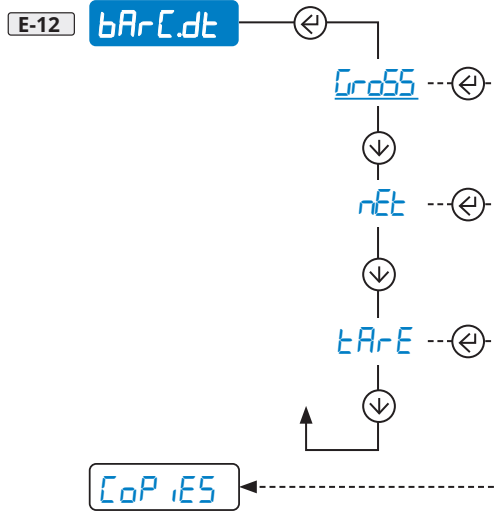

Multi-copy prints

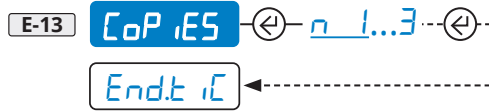

Paper outlet for end of label

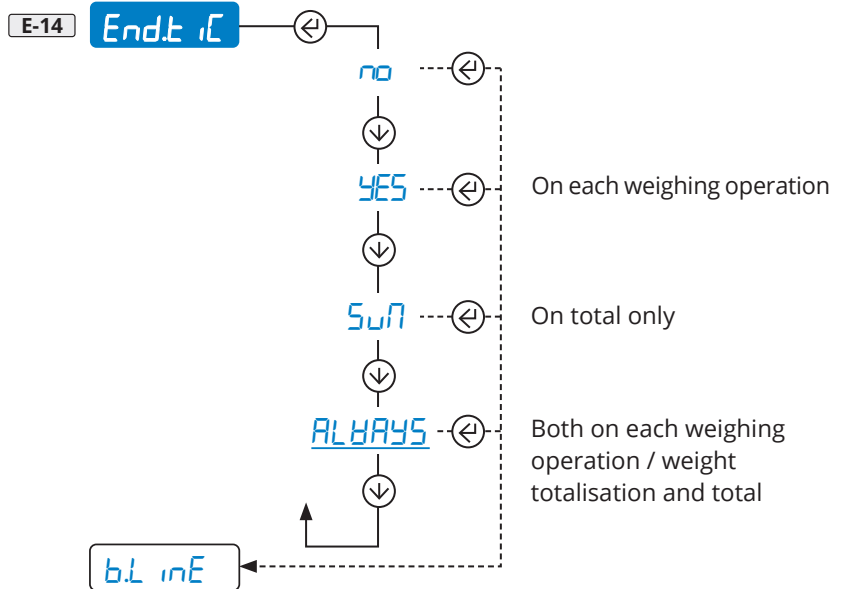

White pre-heating line of the print head

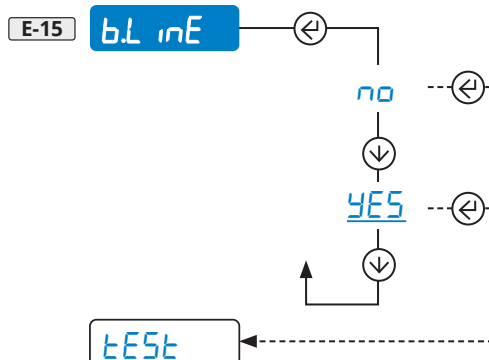

MENU

Enter	Browse	Save and exit
1. Off	=	 Page 15
2. On	=	
3.	=	
Page 15	=	

- A CAL
- B 0.CAL
- C CAL.AdU
- D SEr iAL
- E LAYout ↓
- F SCrEEen 1 LANG
- G AutoFF 2 ChAr
- H Scr.SAU 3 hEAdEr
- I rESEt 4 dAtA
- J d iAG 5 WE iGhS
- K AdVAnC 6 t iCREt
- 7 CLoCh
- 8 bArC.39
- 9 bArC.wP
- 10 bArC.L
- 11 bArC.h
- 12 bArC.dt
- 13 CoP iES
- 14 End.t iC
- 15 b.L inE
- 16 tESEt

Label test print

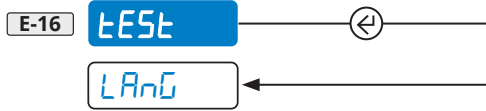

Enter	Browse	Save and exit
1. Off	↑ =	 <i>Page 15</i>
2. On	↓ =	
3.	→ =	
<i>Page 15</i>	← =	

- A CAL
- B 0.CAL
- C CAL ADU
- D SERIAL
- E LAYOUT
- F **SCREEN**
 - 1 **backlit**
 - 2 **brght**
 - 3 **LoCk**
- G AutoOFF
- H SCR.SAV
- I rESEt
- J d iAG
- K ADVANC

Backlighting

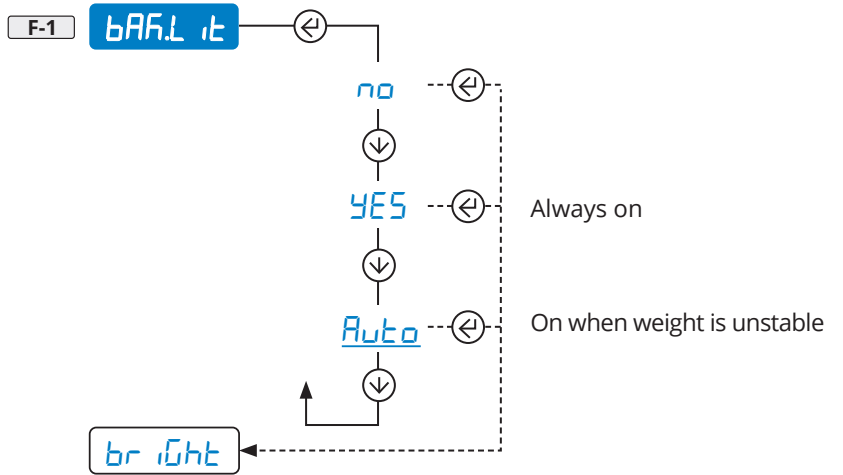

Brightness

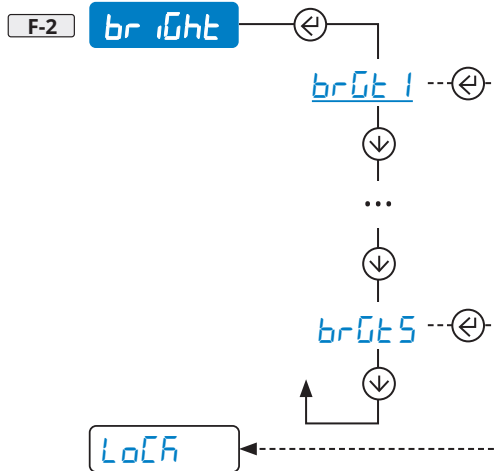

Display lock (for use by the manufacturer)

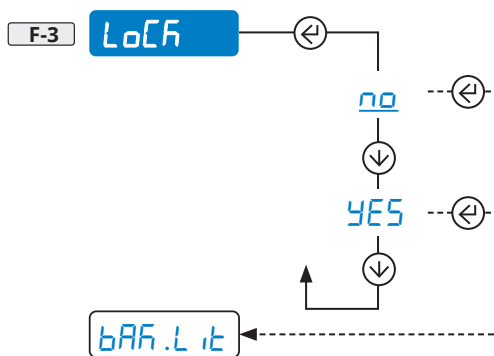

MENU

Enter	Browse	Save and exit
1. Off	=	
2. On	=	Page 15
3.	=	
Page 15	=	

- A CAL
- B 0.CAL
- C CAL.AdU
- D SEr iAL
- E LAYout
- F SCrEEen
- G AutoFF
- H SCr.SAU
- I rESEt
- J d iAG
- K AdVAnC

AutoFF Auto switch-off

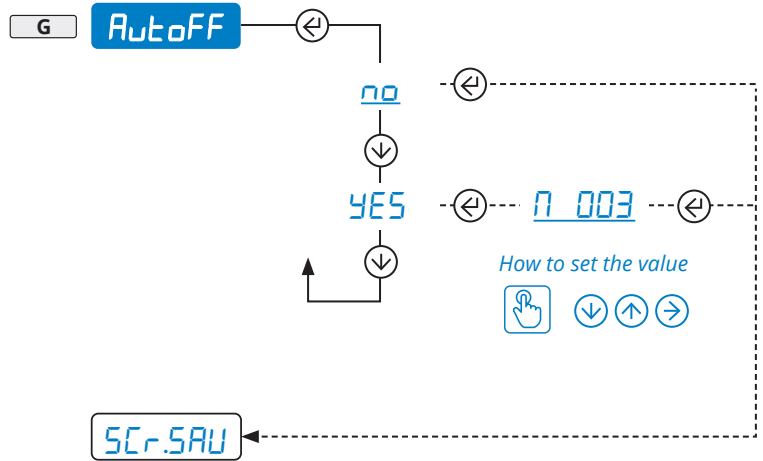



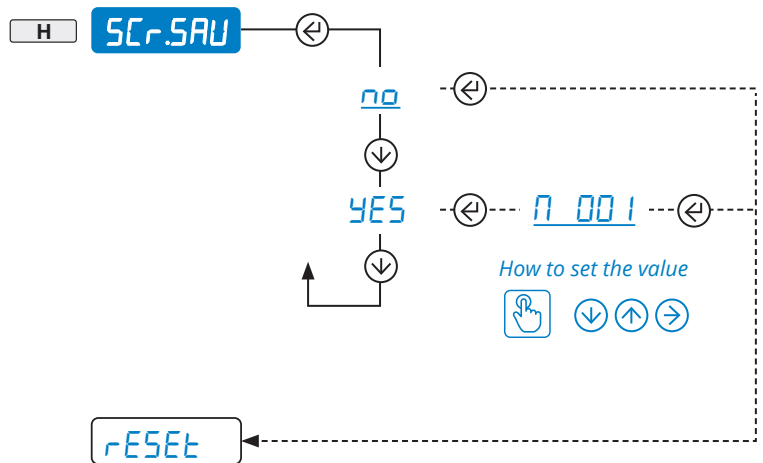





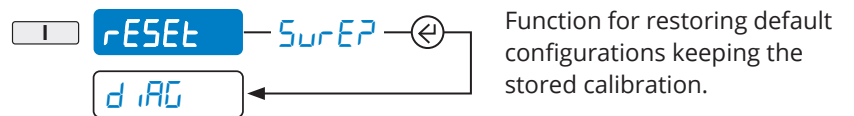





SCr.SAU Screen-saver setting



The screen-saver function is only active if the alibi memory / clock option is present.



rESEt Factory configuration reset



Enter	Browse	Save and exit
1. Off 	 = 	 <i>Page 15</i>
2. On 	 = 	
3. 	 = 	
 <i>Page 15</i>	 = 	

- A CAL
- B 0.CAL
- C CALAdU
- D SEr iAL
- E LAYout
- F SCrEEen
- G AutoFF
- H Scr.SAU
- I rESEt
- J **d iAG**
- K AdUAnC
 - 1 AdC.uU
 - 2 d iSPLA
 - 3 KEyb
 - 4 CtS
 - 5 SEr.nuN
 - 6 PrG.UEr
 - 7 d iU. int
 - 8 AdC.Pnt
 - 9 bt.AdC
 - 10 SEr iAL

d iAG Diagnostics

- J-1 **AdC.uU** Converter Check of input signal in μV . Press the keys  or  to toggle the display between the two forks.
- J-2 **d iSPLA** Display. Integrity check of all segments and icons.
- J-3 **KEyb** Keypad. Press any key to check its correct operation, with beep and code on display.
- J-4 **CtS** CTS. Check of status of the control signal from the printer.
- J-5 **SEr.nuN** Scale serial number.
- J-6 **PrG.UEr** Hardware version (e.g. *rEU5*) followed by software version (e.g. *04.00.00*).
- J-7 **d iU. int** For use by the manufacturer.
- J-8 **AdC.Pnt** For use by the manufacturer.
- J-9 **bt.AdC** For use by the manufacturer.
- J-10 **SEr iAL** For use by the manufacturer.

MENU

Enter	Browse	Save and exit
1. Off	↑ =	 Page 15
2. On	↓ =	
3.	→ =	
Page 15	← =	

- A **CAL**
- B **0.CAL**
- C **CAL.AdU**
- D **SEr iAL**
- E **LAYout**
- F **SCrEEen**
- G **AutoFF**
- H **Scr.SAU**
- I **rESEt**
- J **d iAG**
- K **AdVAnC**

- 1 **LoCkAb**
- 3 **P in.tEE**
- 4 **P in.uSE**
- 5 **dFLt.t**

Permanent keyboard lock (excluding key)

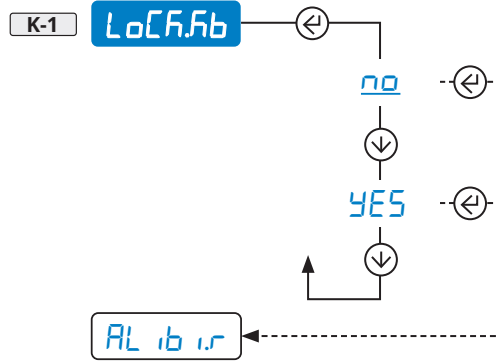

Access PIN to programming menu

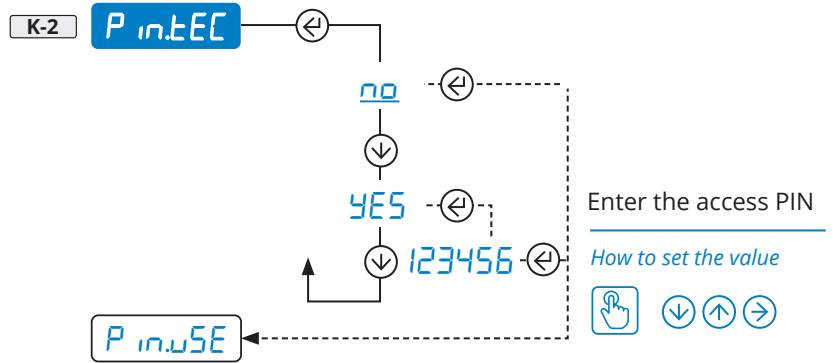

Access PIN for sub-menu **d iAG** of the user menu



Total reset of memory and of calibration, with reset of the factory settings.

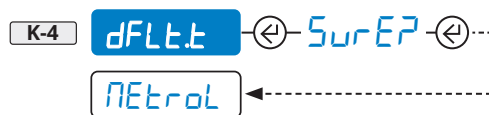

Short string

01ST,GS, 0.0,kg<CR><LF>

where

01	Code 485 of the instrument (2 characters), only if communication mode 485 is enabled
ST	Scale status (2 characters): <u>US</u> - Unstable weight <u>ST</u> - Stable weight <u>OL</u> - Weight overload (out of range) <u>UL</u> - Weight underload (out of range) <u>TL</u> - Scale not level (inclinometer active)
,	ASCII 044 character
GS	Type of weight data (2 characters) <u>GS</u> - Gross <u>NT</u> - Net
,	ASCII 044 character
0.0	Weight (8 characters including the decimal point)
,	ASCII 044 character
kg	Unit of measurement (2 characters)
<CR><LF>	Transmission terminator, characters ASCII 013 and ASCII 010

Extended string

011ST, 0.0,PT 20.8, 0,kg<CR><LF>

where

01	Code 485 of the instrument (2 characters), only if communication mode 485 is enabled
1	ASCII 049 character
ST	Scale status (2 characters): <u>US</u> - Unstable weight <u>ST</u> - Stable weight <u>OL</u> - Weight overload (out of range) <u>UL</u> - Weight underload (out of range) <u>TL</u> - Scale not level (inclinometer active)
,	ASCII 044 character
,	ASCII 044 character
0.0	Net weight (10 characters including the decimal point)
,	ASCII 044 character
PT	Indication of pre-set manual tare (2 characters)
20.8	Tare weight (10 characters including the decimal point)
,	ASCII 044 character
0	Number of pieces (10 characters)
,	ASCII 044 character
kg	Unit of measurement (2 characters)
<CR><LF>	Transmission terminator, characters ASCII 013 and ASCII 010

Wiring diagram

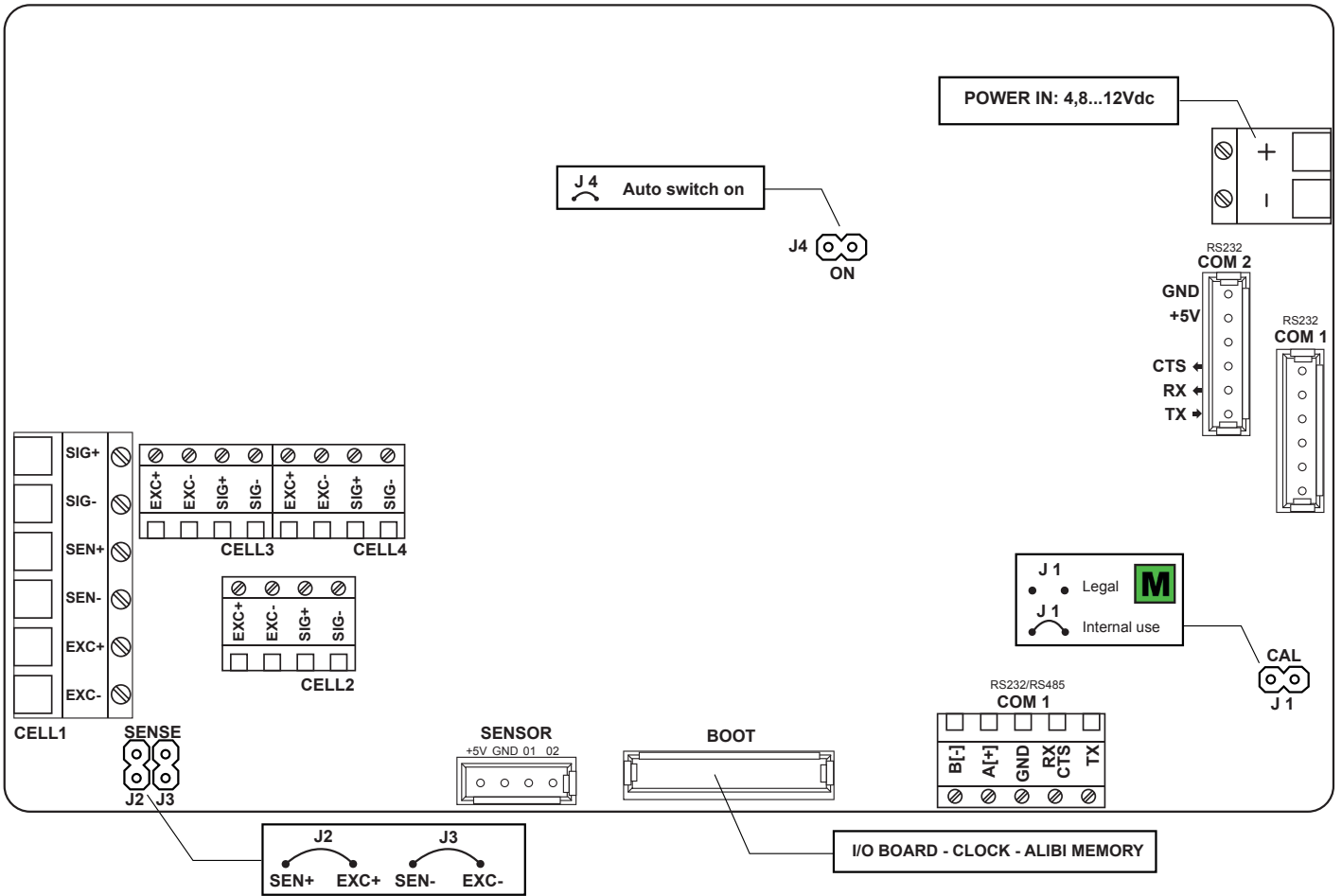

MESSAGE	DESCRIPTION	SOLUTION
<i>AL.Err</i>	"Alibi memory" board (optional) not detected.	Check the presence of the board inside the indicator. If present, check it is not damaged and is installed correctly.
<i>Pr.EC.</i>	Calibration error.	First calibrate the zero point, then proceed with the next points.
<i>Err.Pnt</i>	Calibration error.	Check the connection of the load cell. Check that the cell signal is stable, valid and greater than that of the previously acquired point.
<i>Er 11</i>	Calibration error.	Increase the calibration weight.
<i>Er 12</i>	Calibration error.	Check that the signal coming from the cell increases upon the increasing of the weight loaded on the scale. When acquiring the calibration points, use the increasing calibration weights.
<i>Er 37</i>	Calibration error.	Repeat the calibration, checking that the capacity and division have been correctly set.
<i>Er 39</i>	Instrument not configured.	Reset the factory configurations (menu <i>AdUAnC</i> , parameter <i>dFLtL</i> , see page 41).
<i>Er 85</i>	Instrument configured but not calibrated.	Perform calibration.
<i>CEr.36</i>	Calibration error.	Check that the signal coming from the load cell is not negative.
<i>Err.Not</i>	Unstable weight	Check in the menu <i>d.AG</i> , parameter <i>AdC.WJ</i> (see page 34) that the signal is stable and try again. If the connection of the cells is with 4 wires, check that the sense jumpers are inserted.
<i>H.oUER</i>	Linearisation error	The acquired weight is greater than the saved calibration point. Perform linearisation with a lower weight or recalibrate the system with a higher calibration weight.

Summary of the parameters

CAL	Calibration.....	15
0.CAL	Zeroring the pre-tare (zero calibration).....	23
CAL ADJ	Complete calibration.....	23
CAL.PAR	Calibration parameters.....	23
dEC IN	Configuration of the decimal point.....	23
dIU	Reading division.....	23
uM.	Unit of measure.....	24
rANGE 1	Scale capacity (maximum capacity / first weighing range).....	24
rANGE 2	For multirange scales (second weighing range).....	24
2Ero	Advanced calibration.....	24
MEtroL	Metrological parameters.....	25
FILtEr	Weighing filters.....	25
dIUStb	Sensitivity of the weight stability control.....	25
CAL ADJ	Re-acquisition / change of the calibration points in memory.....	25
CAL.MAN	For use by the manufacturer.....	25
SErIAL	Configuration of the serial ports.....	26
CoN.PC	Communication with PC, PLC or repeater.....	26
ModE	Selection of the communication mode.....	26
CoN.SEL	COM port selection for PC / PLC connection.....	26
bAud	Communication speed (Baud rate).....	27
bit	Configuration of the serial protocol.....	27
CoN.Prn	Communication with printer or repeater or PC.....	28
bAud	Communication speed (Baud rate).....	28
bit	Configuration of the serial protocol.....	28
CTS	Printer control signal.....	29
POW.Er.P	Printer power supply / Radio-frequency module.....	30
AdVAnC	Advanced configurations.....	30
ProtoC	Communication protocol.....	30
tTLtIL	TTL port (for use by the manufacturer).....	30
tErM	Closing character of each print line.....	30
iGnorE	Ignore unknown commands.....	30
LAYout	Print customisation.....	31
LANG	Setting of the print language (<i>ITAL, ENGL, DEut, FRAN, ESPA, Ch inES</i>).....	32
ChAr	Setting the font.....	32
hEAdEr	Print header.....	33
dAtA	Selection of the weight data.....	35
WE iGht	Progressive weighed.....	35
t iCREt	Receipt / label progressive.....	35
CLoCk	Date and time.....	36
bARc.39	Bar code 39.....	36
bARc.WP	Barcode top margin (mm).....	36
bARc.L	Barcode left margin (mm).....	36
bARc.h	Barcode height (mm).....	36

bArC.dE	Selection of the weight data.....	37
CoP.iES	Multi-copy prints.....	37
End.t.iC	Paper outlet for end of label / receipt.....	37
b.L.inE	White printhead preheating line (thermal printer only).....	37
tESEt	Saving labels in the printer's memory and test printing all formats	38
SCrEEEn	Adjusting the display.....	39
bARFLit	Backlighting.....	39
br.iGht	Brightness.....	39
LoCK	Display lock (for use by the manufacturer)	39
AutoFF	Auto switch-off.....	40
SCr.SAV	Screen-saver.....	40
rESEt	Factory configuration reset.....	40
d.iAG	Diagnostics	41
AdC.uU	Converter	41
d.iSPLA	Display.....	41
KEYb	Keypad	41
AdUAnC	Advanced.....	42
LoCK.Kb	Permanent keyboard lock (excluding key ).....	42
P.in.tEE	Access PIN to programming menu.....	42
P.in.uSE	Access PIN to user menus	42
dFLt.t	Total reset of memory and calibration	42





A RICE LAKE WEIGHING SYSTEMS COMPANY

HEAD OFFICE

Via Della Fisica, 20
41042 Spezzano di Fiorano, Modena - Italy
Tel. +39 0536 843418 - Fax +39 0536 843521

SERVICE ASSISTANCE

Via Dell'Elettronica, 15
41042 Spezzano di Fiorano, Modena - Italy
Tel. +39 0536 921784 - Fax +39 0536 926654

www.diniargeo.com

Stamp of the authorised service centre

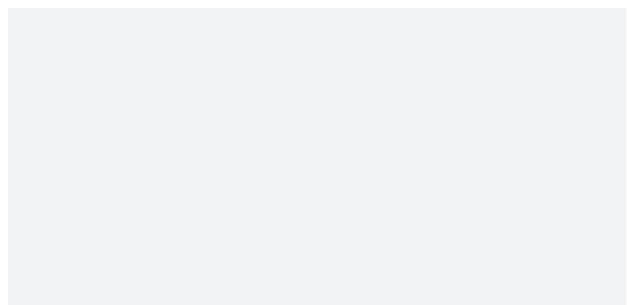

The information in this document is approximate and can be subject to variations without prior notice by Dini Argeo, in compliance with the norms in force. The official technical data are available in the updated version on the following website www.diniargeo.com or by contacting Dini Argeo Customer Service.

TECH_MAN_ENG_LTP
Rev. 24.06.2021