

# PROFINET1S/ETHERNETIP1S

**QUICK START GUIDE**  
for DGT1Sxx with firmware version from 08.00.00

**ENGLISH**

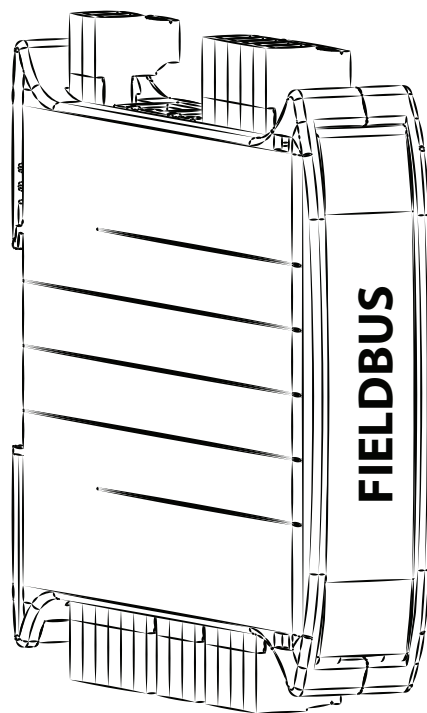





### 3. Profinet/EthernetIP function mode: SINGLE SCALE or HUB MODE

Function 1: Single scale mode

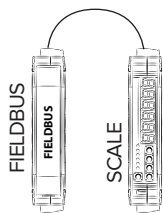

Function 2: Hub mode

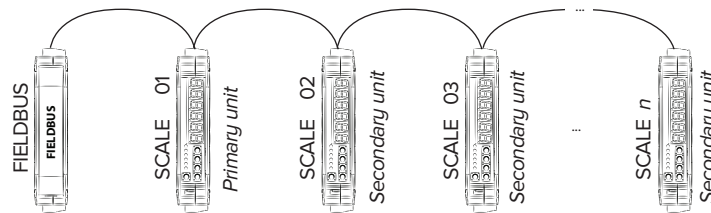

Single scale mode configuration

	Scale
hub	no
Aut.CFG	no
iP.Add	000.000.000.000
net.MSK	000.000.000.000
Gate.WAY	000.000.000.000

Hub mode configuration

Primary	Scale 01
hub	YES
Pr.inPr	YES
Aut.CFG	no
iP.Add	000.000.000.000
net.MSK	000.000.000.000
Gate.WAY	000.000.000.000

Secondary	Scale 02	Scale 03	Scale n
hub	YES	YES	YES
Pr.inPr	no	no	no
SCA.Add	2	3	n

In hub mode, primary unit (scale 01) needs the configuration of all the parameters, secondary units need the configuration of a few parameters only

### 4. Profinet/EthernetIP configuration (through weight transmitter menu)

Configuration has to be made by the weight transmitter setup:

1. Reboot the weight transmitter
2. Press the ► key when display shows the 888888 message:

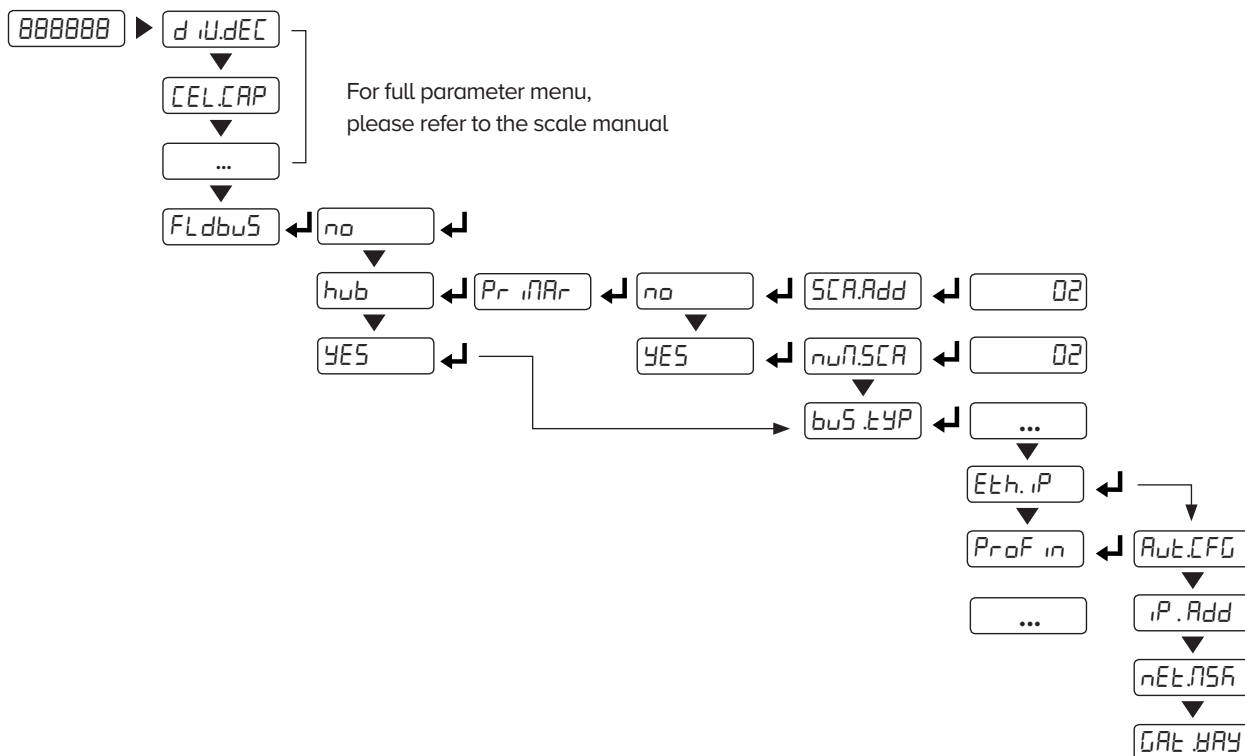

### 5. Profinet/EthernetIP parameters description

- hub** Enable the HUB mode
- Aut.CFG** Dynamic configuration made by the network
- Pr.inPr** In HUB mode, it identifies the “primary scale” of the network, on which all Canopen parameters are set.  
Take note: if FLdbuS = “YES” or “hub”, RS485 baud rate is automatically set to 115200 and scale address = 01.
- iP.Add** Set the IP address
- net.MSK** Set the net mask address
- Gate.WAY** Set the default gateway

## 6. Profinet/EthernetIP Input data area (for data reading) - SINGLE SCALE mode

Data	Byte	DESCRIPTION	EXAMPLE																														
Gross weight	1 <sub>(MSB)</sub>	Bytes 1, 2, 3 and 4 contain the Gross Weight value	<table border="1"> <thead> <tr> <th colspan="5">Gross weight value examples</th> </tr> <tr> <th></th> <th>1000</th> <th>6000</th> <th>15000</th> <th>350000</th> </tr> </thead> <tbody> <tr> <td>1<sub>(MSB)</sub></td> <td>00 Hex</td> <td>00 Hex</td> <td>00 Hex</td> <td>00 Hex</td> </tr> <tr> <td>2</td> <td>00 Hex</td> <td>00 Hex</td> <td>00 Hex</td> <td>05 Hex</td> </tr> <tr> <td>3</td> <td>03 Hex</td> <td>17 Hex</td> <td>3A Hex</td> <td>57 Hex</td> </tr> <tr> <td>4<sub>(LSB)</sub></td> <td>E8 Hex</td> <td>70 Hex</td> <td>98 Hex</td> <td>30 Hex</td> </tr> </tbody> </table>	Gross weight value examples						1000	6000	15000	350000	1 <sub>(MSB)</sub>	00 Hex	00 Hex	00 Hex	00 Hex	2	00 Hex	00 Hex	00 Hex	05 Hex	3	03 Hex	17 Hex	3A Hex	57 Hex	4 <sub>(LSB)</sub>	E8 Hex	70 Hex	98 Hex	30 Hex
	Gross weight value examples																																
				1000	6000	15000	350000																										
	1 <sub>(MSB)</sub>			00 Hex	00 Hex	00 Hex	00 Hex																										
2	00 Hex	00 Hex	00 Hex	05 Hex																													
3	03 Hex	17 Hex	3A Hex	57 Hex																													
4 <sub>(LSB)</sub>	E8 Hex	70 Hex	98 Hex	30 Hex																													
2																																	
3																																	
4 <sub>(LSB)</sub>																																	
Net weight	5 <sub>(MSB)</sub>	Bytes 5, 6, 7 and 8 contain the Net Weight value	<table border="1"> <thead> <tr> <th colspan="5">Net weight value examples</th> </tr> <tr> <th></th> <th>1000</th> <th>6000</th> <th>15000</th> <th>350000</th> </tr> </thead> <tbody> <tr> <td>5<sub>(MSB)</sub></td> <td>00 Hex</td> <td>00 Hex</td> <td>00 Hex</td> <td>00 Hex</td> </tr> <tr> <td>6</td> <td>00 Hex</td> <td>00 Hex</td> <td>00 Hex</td> <td>05 Hex</td> </tr> <tr> <td>7</td> <td>03 Hex</td> <td>17 Hex</td> <td>3A Hex</td> <td>57 Hex</td> </tr> <tr> <td>8<sub>(LSB)</sub></td> <td>E8 Hex</td> <td>70 Hex</td> <td>98 Hex</td> <td>30 Hex</td> </tr> </tbody> </table>	Net weight value examples						1000	6000	15000	350000	5 <sub>(MSB)</sub>	00 Hex	00 Hex	00 Hex	00 Hex	6	00 Hex	00 Hex	00 Hex	05 Hex	7	03 Hex	17 Hex	3A Hex	57 Hex	8 <sub>(LSB)</sub>	E8 Hex	70 Hex	98 Hex	30 Hex
	Net weight value examples																																
				1000	6000	15000	350000																										
	5 <sub>(MSB)</sub>			00 Hex	00 Hex	00 Hex	00 Hex																										
6	00 Hex	00 Hex	00 Hex	05 Hex																													
7	03 Hex	17 Hex	3A Hex	57 Hex																													
8 <sub>(LSB)</sub>	E8 Hex	70 Hex	98 Hex	30 Hex																													
6																																	
7																																	
8 <sub>(LSB)</sub>																																	
Input Status	9 <sub>(MSB)</sub>	Bit 7 <sub>(msb)</sub> No function Bit 6 No function Bit 5 No function Bit 4 No function Bit 3 No function Bit 2 No function Bit 1 Status of input n.2 (0= OFF; 1= ON) Bit 0 <sub>(lsb)</sub> Status of input n.1 (0= OFF; 1= ON)	<table border="1"> <thead> <tr> <th colspan="5">Input status</th> </tr> <tr> <th></th> <th>IN1= OFF IN2= OFF</th> <th>IN1= ON IN2= OFF</th> <th>IN1= OFF IN2= ON</th> <th>IN1= ON IN2= ON</th> </tr> </thead> <tbody> <tr> <td>9<sub>(MSB)</sub></td> <td>00 Hex</td> <td>01 Hex</td> <td>02 Hex</td> <td>03 Hex</td> </tr> <tr> <td>10<sub>(LSB)</sub></td> <td>-</td> <td>-</td> <td>-</td> <td>-</td> </tr> </tbody> </table>	Input status						IN1= OFF IN2= OFF	IN1= ON IN2= OFF	IN1= OFF IN2= ON	IN1= ON IN2= ON	9 <sub>(MSB)</sub>	00 Hex	01 Hex	02 Hex	03 Hex	10 <sub>(LSB)</sub>	-	-	-	-										
	Input status																																
	IN1= OFF IN2= OFF	IN1= ON IN2= OFF	IN1= OFF IN2= ON	IN1= ON IN2= ON																													
9 <sub>(MSB)</sub>	00 Hex	01 Hex	02 Hex	03 Hex																													
10 <sub>(LSB)</sub>	-	-	-	-																													
10 <sub>(LSB)</sub>	Bit 7 <sub>(msb)</sub> 1 = Scale unloaded (gross weight = 0) Bit 6 Tare PT (1= PT tare is active) Bit 5 Tare (1 = Tare is active) Bit 4 Overload condition (0= No; 1 = Overload) Bit 3 Underload condition (0= No; 1 = Underload) Bit 2 Weight Stability (0= Unstable ; 1= Stable) Bit 1 Gross Weight Polarity (0= "+" ; 1 = "-") Bit 0 <sub>(lsb)</sub> Net Weight Polarity (0= "+" ; 1 = "-")	If BYTE 10 <sub>(LSB)</sub> = 45 HEX: <table border="1"> <thead> <tr> <th>Bit 7</th> <th>Bit 6</th> <th>Bit 5</th> <th>Bit 4</th> <th>Bit 3</th> <th>Bit 2</th> <th>Bit 1</th> <th>Bit 0</th> </tr> </thead> <tbody> <tr> <td>0</td> <td>1</td> <td>1</td> <td>0</td> <td>0</td> <td>1</td> <td>0</td> <td>1</td> </tr> </tbody> </table> Bit 0 = Net weight is negative Bit 1 = Gross weight is positive Bit 2 = Weight is stable Bit 5/6 = A Preset Tare is in memory	Bit 7	Bit 6	Bit 5	Bit 4	Bit 3	Bit 2	Bit 1	Bit 0	0	1	1	0	0	1	0	1															
Bit 7	Bit 6	Bit 5	Bit 4	Bit 3	Bit 2	Bit 1	Bit 0																										
0	1	1	0	0	1	0	1																										
-	11 <sub>(MSB)</sub>	Last received command	See table in reg. nr. 40001 of the holding registers table																														
Command Status Register	12 <sub>(LSB)</sub>	Bit 7 <sub>(msb)</sub> Last command result	Bit 0 to Bit 3 are used as a counter of received commands, from 0 (0000) to 15 (1111). Bit 4 to Bit 7 are used to indicate the result of the last received command: <table border="1"> <thead> <tr> <th>Bit 7</th> <th>Bit 6</th> <th>Bit 5</th> <th>Bit 4</th> <th>Result</th> </tr> </thead> <tbody> <tr> <td>0</td> <td>0</td> <td>0</td> <td>0</td> <td>Command OK</td> </tr> <tr> <td>0</td> <td>0</td> <td>0</td> <td>1</td> <td>Incorrect command</td> </tr> <tr> <td>0</td> <td>0</td> <td>1</td> <td>0</td> <td>Incorrect command data</td> </tr> <tr> <td>0</td> <td>0</td> <td>1</td> <td>1</td> <td>Command not allowed</td> </tr> <tr> <td>0</td> <td>1</td> <td>0</td> <td>0</td> <td>Inexistent command</td> </tr> </tbody> </table>	Bit 7	Bit 6	Bit 5	Bit 4	Result	0	0	0	0	Command OK	0	0	0	1	Incorrect command	0	0	1	0	Incorrect command data	0	0	1	1	Command not allowed	0	1	0	0	Inexistent command
		Bit 7		Bit 6	Bit 5	Bit 4	Result																										
		0		0	0	0	Command OK																										
		0		0	0	1	Incorrect command																										
		0		0	1	0	Incorrect command data																										
		0		0	1	1	Command not allowed																										
		0		1	0	0	Inexistent command																										
Bit 6 Last command result																																	
Bit 5 Last command result																																	
Bit 4 Last command result																																	
Bit 3 Counting of processed commands																																	
Bit 2 Counting of processed commands																																	
Bit 1 Counting of processed commands																																	
Bit 0 <sub>(lsb)</sub> Counting of processed commands																																	
-	13 <sub>(MSB)</sub>	No Function	<table border="1"> <thead> <tr> <th colspan="5">Output status</th> </tr> <tr> <th></th> <th>IN1= OFF IN2= OFF</th> <th>IN1= ON IN2= OFF</th> <th>IN1= OFF IN2= ON</th> <th>IN1= ON IN2= ON</th> </tr> </thead> <tbody> <tr> <td>13<sub>(MSB)</sub></td> <td>-</td> <td>-</td> <td>-</td> <td>-</td> </tr> <tr> <td>14<sub>(LSB)</sub></td> <td>00 Hex</td> <td>01 Hex</td> <td>02 Hex</td> <td>03 Hex</td> </tr> </tbody> </table>	Output status						IN1= OFF IN2= OFF	IN1= ON IN2= OFF	IN1= OFF IN2= ON	IN1= ON IN2= ON	13 <sub>(MSB)</sub>	-	-	-	-	14 <sub>(LSB)</sub>	00 Hex	01 Hex	02 Hex	03 Hex										
Output status																																	
	IN1= OFF IN2= OFF	IN1= ON IN2= OFF		IN1= OFF IN2= ON	IN1= ON IN2= ON																												
13 <sub>(MSB)</sub>	-	-	-	-																													
14 <sub>(LSB)</sub>	00 Hex	01 Hex	02 Hex	03 Hex																													
Output status register	14 <sub>(LSB)</sub>	Bit 7 <sub>(msb)</sub> No function																															
		... ..																															
		Bit 2 No function																															
-	...	Bit 1 Digital output 2 status (0 = OFF; 1 = ON)	-																														
		Bit 0 <sub>(lsb)</sub> Digital output 1 status (0 = OFF; 1 = ON)																															
-	15	-	-																														
-	...	-	-																														
-	32	-	-																														

\* Please refer to the complete manual for the full list of available data

## 7. Profinet/EthernetIP Input data area (for data reading) - HUB mode

DATA*	△△ 1	△△ 2	△△ 3	△△ 4	△△ ...	△△ 16	DESCRIPTION / EXAMPLE																																
In/Out status	1	9	17	25	...	121	<table border="1"> <thead> <tr> <th>Bit 7</th> <th>Bit 6</th> <th>Bit 5</th> <th>Bit 4</th> <th>Bit 3</th> <th>Bit 2</th> <th>Bit 1</th> <th>Bit 0</th> </tr> </thead> <tbody> <tr> <td>0</td> <td>0</td> <td>0</td> <td>0</td> <td>0</td> <td>0</td> <td>0</td> <td>0</td> </tr> </tbody> </table> <p>           Bit 7 Scale present bit (Fixed value = 1)            Bit 6/5 Progressive command loop counter;            Values: 0 (00), 1 (01), 2 (10), 3 (11).            Bit 4 Last command result (0 = OK; 1 = ERROR)            Bit 3 Status of output n.2 (0 = OFF; 1 = ON)            Bit 2 Status of output n.1 (0 = OFF; 1 = ON)            Bit 1 Status of input n.2 (0 = OFF; 1 = ON)            Bit 0 Status of input n.1 (0 = OFF; 1 = ON)         </p> <p><b>EXAMPLE:</b>            If Byte 1 = 13 Hex:</p> <table border="1"> <thead> <tr> <th>Bit 7</th> <th>Bit 6</th> <th>Bit 5</th> <th>Bit 4</th> <th>Bit 3</th> <th>Bit 2</th> <th>Bit 1</th> <th>Bit 0</th> </tr> </thead> <tbody> <tr> <td>0</td> <td>0</td> <td>0</td> <td>0</td> <td>1</td> <td>1</td> <td>0</td> <td>1</td> </tr> </tbody> </table> <p>           Bit 0 = Input 1 is ON            Bit 2 = Output 1 is ON            Bit 3 = Output 2 is ON         </p>	Bit 7	Bit 6	Bit 5	Bit 4	Bit 3	Bit 2	Bit 1	Bit 0	0	0	0	0	0	0	0	0	Bit 7	Bit 6	Bit 5	Bit 4	Bit 3	Bit 2	Bit 1	Bit 0	0	0	0	0	1	1	0	1
							Bit 7	Bit 6	Bit 5	Bit 4	Bit 3	Bit 2	Bit 1	Bit 0																									
0	0	0	0	0	0	0	0																																
Bit 7	Bit 6	Bit 5	Bit 4	Bit 3	Bit 2	Bit 1	Bit 0																																
0	0	0	0	1	1	0	1																																
Gross weight	2 <sub>(MSB)</sub>	10 <sub>(MSB)</sub>	18 <sub>(MSB)</sub>	26 <sub>(MSB)</sub>	...	122 <sub>(MSB)</sub>	For each scale there are three bytes containing the Gross Weight value <table border="1"> <thead> <tr> <th>△△ 1</th> <th>3000 kg</th> </tr> </thead> <tbody> <tr> <td>2<sub>(MSB)</sub></td> <td>00 Hex</td> </tr> <tr> <td>3</td> <td>0B Hex</td> </tr> <tr> <td>4<sub>(LSB)</sub></td> <td>B8 Hex</td> </tr> </tbody> </table>	△△ 1	3000 kg	2 <sub>(MSB)</sub>	00 Hex	3	0B Hex	4 <sub>(LSB)</sub>	B8 Hex																								
	△△ 1	3000 kg																																					
	2 <sub>(MSB)</sub>	00 Hex																																					
3	0B Hex																																						
4 <sub>(LSB)</sub>	B8 Hex																																						
3	11	19	27	...	123																																		
4 <sub>(LSB)</sub>	12 <sub>(LSB)</sub>	20 <sub>(LSB)</sub>	28 <sub>(LSB)</sub>	...	124 <sub>(LSB)</sub>																																		
Scale status	5	13	21	29	...	125	<table border="1"> <thead> <tr> <th>Bit 7</th> <th>Bit 6</th> <th>Bit 5</th> <th>Bit 4</th> <th>Bit 3</th> <th>Bit 2</th> <th>Bit 1</th> <th>Bit 0</th> </tr> </thead> <tbody> <tr> <td>0</td> <td>0</td> <td>0</td> <td>0</td> <td>0</td> <td>0</td> <td>0</td> <td>0</td> </tr> </tbody> </table> <p>           Bit 7 1 = Scale unloaded (gross weight = 0)            Bit 6 Tare PT (1= PT tare is active)            Bit 5 Tare (1 = Tare is active)            Bit 4 Overload condition (0= No; 1 = Overload)            Bit 3 Underload condition (0= No ; 1 = Underload)            Bit 2 Weight Stability (0= Unstable ; 1= Stable)            Bit 1 Gross Weight Polarity (0= "+" ; 1 = "-")            Bit 0 Net Weight Polarity (0= "+" ; 1 = "-")         </p> <p><b>EXAMPLE:</b>            If BYTE 5 = 45 HEX:</p> <table border="1"> <thead> <tr> <th>Bit 7</th> <th>Bit 6</th> <th>Bit 5</th> <th>Bit 4</th> <th>Bit 3</th> <th>Bit 2</th> <th>Bit 1</th> <th>Bit 0</th> </tr> </thead> <tbody> <tr> <td>0</td> <td>1</td> <td>1</td> <td>0</td> <td>0</td> <td>1</td> <td>0</td> <td>1</td> </tr> </tbody> </table> <p>           Bit 0 = Net weight is negative            Bit 1 = Gross weight is positive            Bit 2 = Weight is stable            Bit 5/6 = A Preset Tare is in memory         </p>	Bit 7	Bit 6	Bit 5	Bit 4	Bit 3	Bit 2	Bit 1	Bit 0	0	0	0	0	0	0	0	0	Bit 7	Bit 6	Bit 5	Bit 4	Bit 3	Bit 2	Bit 1	Bit 0	0	1	1	0	0	1	0	1
							Bit 7	Bit 6	Bit 5	Bit 4	Bit 3	Bit 2	Bit 1	Bit 0																									
0	0	0	0	0	0	0	0																																
Bit 7	Bit 6	Bit 5	Bit 4	Bit 3	Bit 2	Bit 1	Bit 0																																
0	1	1	0	0	1	0	1																																
Net Weight	6 <sub>(MSB)</sub>	14 <sub>(MSB)</sub>	22 <sub>(MSB)</sub>	30 <sub>(MSB)</sub>	...	126 <sub>(MSB)</sub>	For each scale there are three bytes contain the Net Weight value <table border="1"> <thead> <tr> <th>△△ 3</th> <th>1000 kg</th> </tr> </thead> <tbody> <tr> <td>22<sub>(MSB)</sub></td> <td>00 Hex</td> </tr> <tr> <td>23</td> <td>03 Hex</td> </tr> <tr> <td>24<sub>(LSB)</sub></td> <td>E8 Hex</td> </tr> </tbody> </table>	△△ 3	1000 kg	22 <sub>(MSB)</sub>	00 Hex	23	03 Hex	24 <sub>(LSB)</sub>	E8 Hex																								
	△△ 3	1000 kg																																					
	22 <sub>(MSB)</sub>	00 Hex																																					
23	03 Hex																																						
24 <sub>(LSB)</sub>	E8 Hex																																						
7	15	23	31	...	127																																		
8 <sub>(LSB)</sub>	16 <sub>(LSB)</sub>	24 <sub>(LSB)</sub>	32 <sub>(LSB)</sub>	...	128 <sub>(LSB)</sub>																																		

## 8. Profinet/EthernetIP output data area (for sending commands)

Command	Byte	Description	Example																											
Transmitter ID	1	It allows to select the transmitter which receives the command:	For zeroing the weight of transmitter number 4:  <table border="1"> <thead> <tr> <th>Byte</th> <th>Value</th> </tr> </thead> <tbody> <tr> <td>1</td> <td>04 Hex</td> </tr> <tr> <td>2</td> <td>01 Hex</td> </tr> </tbody> </table>	Byte	Value	1	04 Hex	2	01 Hex																					
		Byte		Value																										
1	04 Hex																													
2	01 Hex																													
		<table border="1"> <thead> <tr> <th>Transmitter</th> <th>Value</th> </tr> </thead> <tbody> <tr> <td>Transmitter 01</td> <td>01 Hex</td> </tr> <tr> <td>Transmitter 02</td> <td>02 Hex</td> </tr> <tr> <td>Transmitter 03</td> <td>03 Hex</td> </tr> <tr> <td>...</td> <td>... Hex</td> </tr> <tr> <td>Transmitter 16</td> <td>10 Hex</td> </tr> </tbody> </table> <p>Take note: transmitter ID has to be set for each command.</p>	Transmitter	Value	Transmitter 01	01 Hex	Transmitter 02	02 Hex	Transmitter 03	03 Hex	...	... Hex	Transmitter 16	10 Hex																
Transmitter	Value																													
Transmitter 01	01 Hex																													
Transmitter 02	02 Hex																													
Transmitter 03	03 Hex																													
...	... Hex																													
Transmitter 16	10 Hex																													
Command	2	Main available commands:	<b>EXAMPLE 1</b> For setting a preset tare of 1000 kg, one should: <ol style="list-style-type: none"> <li>Set the transmitter address in byte 1</li> <li>Set the command in byte 2</li> <li>Set the tare value in parameter 1 (byte 3, 4, 5, 6)</li> </ol> <table border="1"> <thead> <tr> <th>Byte</th> <th>Value</th> </tr> </thead> <tbody> <tr> <td>1</td> <td>01 Hex</td> </tr> <tr> <td>2</td> <td>03 Hex</td> </tr> <tr> <td>3<sub>(MSB)</sub></td> <td>00 Hex</td> </tr> <tr> <td>4</td> <td>00 Hex</td> </tr> <tr> <td>5</td> <td>03 Hex</td> </tr> <tr> <td>6<sub>(LSB)</sub></td> <td>E8 Hex</td> </tr> </tbody> </table> <b>EXAMPLE 2</b> For setting the setpoint n. 1 of the scale n. 2, one should: <ol style="list-style-type: none"> <li>Set the transmitter address in byte 1</li> <li>Set the command in byte 2</li> <li>Set the setpoint value in parameter 1 (byte 3, 4, 5, 6)</li> </ol>	Byte	Value	1	01 Hex	2	03 Hex	3 <sub>(MSB)</sub>	00 Hex	4	00 Hex	5	03 Hex	6 <sub>(LSB)</sub>	E8 Hex													
		Byte		Value																										
1	01 Hex																													
2	03 Hex																													
3 <sub>(MSB)</sub>	00 Hex																													
4	00 Hex																													
5	03 Hex																													
6 <sub>(LSB)</sub>	E8 Hex																													
		<table border="1"> <thead> <tr> <th>Value</th> <th>Command</th> </tr> </thead> <tbody> <tr> <td>00 Hex</td> <td>No command</td> </tr> <tr> <td>01 Hex</td> <td>Scale zeroing</td> </tr> <tr> <td>02 Hex</td> <td>Tare</td> </tr> <tr> <td>03 Hex</td> <td>Preset Tare</td> </tr> <tr> <td>0A Hex</td> <td>Setpoint 1 setting</td> </tr> <tr> <td>0B Hex</td> <td>Setpoint 2 setting</td> </tr> <tr> <td>19 Hex</td> <td>Digital output setting</td> </tr> <tr> <td>22 Hex</td> <td>Reboot the weight transmitter</td> </tr> <tr> <td>23 Hex</td> <td>Read the calibration data</td> </tr> <tr> <td>24 Hex</td> <td>Write the calibration data</td> </tr> <tr> <td>25 Hex</td> <td>Calibration point acquisition</td> </tr> <tr> <td>26 Hex</td> <td>Abort the calibration procedure</td> </tr> <tr> <td>28 Hex</td> <td>Lock keyboard (parameter 1 = 0); Unlock keyboard (parameter 1 = 1)</td> </tr> </tbody> </table> <p>Take note: to repeat the last command one should first set the command at the "No command" value (0000 Hex) and then repeat the command.</p> <p>Please refer to the complete manual for more information.</p>	Value	Command	00 Hex	No command	01 Hex	Scale zeroing	02 Hex	Tare	03 Hex	Preset Tare	0A Hex	Setpoint 1 setting	0B Hex	Setpoint 2 setting	19 Hex	Digital output setting	22 Hex	Reboot the weight transmitter	23 Hex	Read the calibration data	24 Hex	Write the calibration data	25 Hex	Calibration point acquisition	26 Hex	Abort the calibration procedure	28 Hex	Lock keyboard (parameter 1 = 0); Unlock keyboard (parameter 1 = 1)
Value	Command																													
00 Hex	No command																													
01 Hex	Scale zeroing																													
02 Hex	Tare																													
03 Hex	Preset Tare																													
0A Hex	Setpoint 1 setting																													
0B Hex	Setpoint 2 setting																													
19 Hex	Digital output setting																													
22 Hex	Reboot the weight transmitter																													
23 Hex	Read the calibration data																													
24 Hex	Write the calibration data																													
25 Hex	Calibration point acquisition																													
26 Hex	Abort the calibration procedure																													
28 Hex	Lock keyboard (parameter 1 = 0); Unlock keyboard (parameter 1 = 1)																													
Parameter 1	3 <sub>(MSB)</sub>	First parameter of the command. Parameter is always expressed in absolute mode (no decimals, no sign).	<table border="1"> <thead> <tr> <th>Byte</th> <th>Value</th> </tr> </thead> <tbody> <tr> <td>1</td> <td>01 Hex</td> </tr> <tr> <td>2</td> <td>03 Hex</td> </tr> <tr> <td>3<sub>(MSB)</sub></td> <td>00 Hex</td> </tr> <tr> <td>4</td> <td>00 Hex</td> </tr> <tr> <td>5</td> <td>03 Hex</td> </tr> <tr> <td>6<sub>(LSB)</sub></td> <td>E8 Hex</td> </tr> </tbody> </table>	Byte	Value	1	01 Hex	2	03 Hex	3 <sub>(MSB)</sub>	00 Hex	4	00 Hex	5	03 Hex	6 <sub>(LSB)</sub>	E8 Hex													
	Byte			Value																										
	1			01 Hex																										
	2			03 Hex																										
3 <sub>(MSB)</sub>	00 Hex																													
4	00 Hex																													
5	03 Hex																													
6 <sub>(LSB)</sub>	E8 Hex																													
4																														
5																														
6 <sub>(LSB)</sub>																														
Parameter 2	7 <sub>(MSB)</sub>	Second parameter of the command. Parameter is always expressed in absolute mode (no decimals, no sign).																												
	8																													
	9																													
	10 <sub>(LSB)</sub>																													
-	11	-	-																											
	...																													
	32																													

\* Please refer to the complete manual for the full list of available data

## 9. Calibration procedure

DESCRIPTION	EXAMPLE																													
1. Send command 23 Hex to the transmitter you want to adjust (transmitter ID has to be specified in byte 1)	<table border="1"> <thead> <tr> <th>Byte</th> <th>Value</th> <th>Description</th> </tr> </thead> <tbody> <tr> <td>1</td> <td>03 Hex</td> <td>Transmitter n. 3</td> </tr> <tr> <td>2</td> <td>23 Hex</td> <td>Command</td> </tr> </tbody> </table>	Byte	Value	Description	1	03 Hex	Transmitter n. 3	2	23 Hex	Command																				
Byte	Value	Description																												
1	03 Hex	Transmitter n. 3																												
2	23 Hex	Command																												
2. Select the 5001 page for calibration using the CHANGE PAGE command (1D Hex)	<table border="1"> <thead> <tr> <th>Byte</th> <th>Value</th> <th>Description</th> </tr> </thead> <tbody> <tr> <td>1</td> <td>03 Hex</td> <td>Transmitter n. 3</td> </tr> <tr> <td>2</td> <td>1D Hex</td> <td>Change page</td> </tr> <tr> <td>3<sub>(MSB)</sub></td> <td>00 Hex</td> <td rowspan="4">5001 (1389 Hex)</td> </tr> <tr> <td>4</td> <td>00 Hex</td> </tr> <tr> <td>5</td> <td>13 Hex</td> </tr> <tr> <td>6<sub>(LSB)</sub></td> <td>89 Hex</td> </tr> </tbody> </table>	Byte	Value	Description	1	03 Hex	Transmitter n. 3	2	1D Hex	Change page	3 <sub>(MSB)</sub>	00 Hex	5001 (1389 Hex)	4	00 Hex	5	13 Hex	6 <sub>(LSB)</sub>	89 Hex											
Byte	Value	Description																												
1	03 Hex	Transmitter n. 3																												
2	1D Hex	Change page																												
3 <sub>(MSB)</sub>	00 Hex	5001 (1389 Hex)																												
4	00 Hex																													
5	13 Hex																													
6 <sub>(LSB)</sub>	89 Hex																													
3. Set the span adjustment weight on page 5001, from byte 19 to 22 (if different from the one used during the last calibration)	<table border="1"> <thead> <tr> <th rowspan="2"></th> <th colspan="4">Weight value examples</th> </tr> <tr> <th>1000</th> <th>6000</th> <th>15000</th> <th>350000</th> </tr> </thead> <tbody> <tr> <td>19<sub>(MSB)</sub></td> <td>00 Hex</td> <td>00 Hex</td> <td>00 Hex</td> <td>00 Hex</td> </tr> <tr> <td>20</td> <td>00 Hex</td> <td>00 Hex</td> <td>00 Hex</td> <td>05 Hex</td> </tr> <tr> <td>21</td> <td>03 Hex</td> <td>17 Hex</td> <td>3A Hex</td> <td>57 Hex</td> </tr> <tr> <td>22<sub>(LSB)</sub></td> <td>E8 Hex</td> <td>70 Hex</td> <td>98 Hex</td> <td>30 Hex</td> </tr> </tbody> </table>		Weight value examples				1000	6000	15000	350000	19 <sub>(MSB)</sub>	00 Hex	00 Hex	00 Hex	00 Hex	20	00 Hex	00 Hex	00 Hex	05 Hex	21	03 Hex	17 Hex	3A Hex	57 Hex	22 <sub>(LSB)</sub>	E8 Hex	70 Hex	98 Hex	30 Hex
	Weight value examples																													
	1000	6000	15000	350000																										
19 <sub>(MSB)</sub>	00 Hex	00 Hex	00 Hex	00 Hex																										
20	00 Hex	00 Hex	00 Hex	05 Hex																										
21	03 Hex	17 Hex	3A Hex	57 Hex																										
22 <sub>(LSB)</sub>	E8 Hex	70 Hex	98 Hex	30 Hex																										
4. Send "WRITE CALIBRATION" command (24 Hex), with: parameter 1 = 5001 (1389 Hex).	See example of point 2., but byte 2=24 Hex (Write Calibration).																													
5. Zero capture: unload the scale and write the "ACQUISITION POINT" command (25 Hex), with parameter 1 = "0".	<table border="1"> <thead> <tr> <th>Byte</th> <th>Value</th> <th>Description</th> </tr> </thead> <tbody> <tr> <td>1</td> <td>03 Hex</td> <td>Transmitter n. 3</td> </tr> <tr> <td>2</td> <td>25 Hex</td> <td>Acquisition point</td> </tr> <tr> <td>3<sub>(MSB)</sub></td> <td>00 Hex</td> <td rowspan="4">Zero point acquisition</td> </tr> <tr> <td>4</td> <td>00 Hex</td> </tr> <tr> <td>5</td> <td>00 Hex</td> </tr> <tr> <td>6<sub>(LSB)</sub></td> <td>00 Hex</td> </tr> </tbody> </table>	Byte	Value	Description	1	03 Hex	Transmitter n. 3	2	25 Hex	Acquisition point	3 <sub>(MSB)</sub>	00 Hex	Zero point acquisition	4	00 Hex	5	00 Hex	6 <sub>(LSB)</sub>	00 Hex											
Byte	Value	Description																												
1	03 Hex	Transmitter n. 3																												
2	25 Hex	Acquisition point																												
3 <sub>(MSB)</sub>	00 Hex	Zero point acquisition																												
4	00 Hex																													
5	00 Hex																													
6 <sub>(LSB)</sub>	00 Hex																													
6. Read the calibration status into page 5001 (byte 30, 31)  If acquisition is OK, then proceed with step 7; otherwise check the load cell mV/V (they have to be stable) and repeat point 5.	<table border="1"> <thead> <tr> <th>30<sub>(MSB)</sub></th> <th>31<sub>(LSB)</sub></th> <th></th> </tr> </thead> <tbody> <tr> <td>00 Hex</td> <td>00 Hex</td> <td>Calibration not started</td> </tr> <tr> <td>00 Hex</td> <td>01 Hex</td> <td>Acquisition underway</td> </tr> <tr> <td>00 Hex</td> <td>02 Hex</td> <td>Acquisition OK</td> </tr> <tr> <td>00 Hex</td> <td>03 Hex</td> <td>Acquisition error</td> </tr> <tr> <td>00 Hex</td> <td>04 Hex</td> <td>Calibration OK</td> </tr> <tr> <td>00 Hex</td> <td>05 Hex</td> <td>Calibration error</td> </tr> </tbody> </table>	30 <sub>(MSB)</sub>	31 <sub>(LSB)</sub>		00 Hex	00 Hex	Calibration not started	00 Hex	01 Hex	Acquisition underway	00 Hex	02 Hex	Acquisition OK	00 Hex	03 Hex	Acquisition error	00 Hex	04 Hex	Calibration OK	00 Hex	05 Hex	Calibration error								
30 <sub>(MSB)</sub>	31 <sub>(LSB)</sub>																													
00 Hex	00 Hex	Calibration not started																												
00 Hex	01 Hex	Acquisition underway																												
00 Hex	02 Hex	Acquisition OK																												
00 Hex	03 Hex	Acquisition error																												
00 Hex	04 Hex	Calibration OK																												
00 Hex	05 Hex	Calibration error																												
7. Span capture: load the scale with span weight and write the "ACQUISITION POINT" command (25 Hex), with parameter 1 = "1".  If acquisition is OK (see step 6), then proceed with step 8; otherwise check the load cell mV/V (they have to be stable and greater than zero point) and repeat point 7.	<table border="1"> <thead> <tr> <th>Byte</th> <th>Value</th> <th>Description</th> </tr> </thead> <tbody> <tr> <td>1</td> <td>03 Hex</td> <td>Transmitter n. 3</td> </tr> <tr> <td>2</td> <td>25 Hex</td> <td>Acquisition point</td> </tr> <tr> <td>3<sub>(MSB)</sub></td> <td>00 Hex</td> <td rowspan="4">Span acquisition</td> </tr> <tr> <td>4</td> <td>00 Hex</td> </tr> <tr> <td>5</td> <td>00 Hex</td> </tr> <tr> <td>6<sub>(LSB)</sub></td> <td>01 Hex</td> </tr> </tbody> </table>	Byte	Value	Description	1	03 Hex	Transmitter n. 3	2	25 Hex	Acquisition point	3 <sub>(MSB)</sub>	00 Hex	Span acquisition	4	00 Hex	5	00 Hex	6 <sub>(LSB)</sub>	01 Hex											
Byte	Value	Description																												
1	03 Hex	Transmitter n. 3																												
2	25 Hex	Acquisition point																												
3 <sub>(MSB)</sub>	00 Hex	Span acquisition																												
4	00 Hex																													
5	00 Hex																													
6 <sub>(LSB)</sub>	01 Hex																													
8. Store calibration using the "WRITE CALIBRATION" command (24 Hex), with parameter 1 = "0"	<table border="1"> <thead> <tr> <th>Byte</th> <th>Value</th> <th>Description</th> </tr> </thead> <tbody> <tr> <td>1</td> <td>03 Hex</td> <td>Transmitter n. 3</td> </tr> <tr> <td>2</td> <td>24 Hex</td> <td>Write calibration</td> </tr> <tr> <td>3<sub>(MSB)</sub></td> <td>00 Hex</td> <td rowspan="4">Store calibration</td> </tr> <tr> <td>4</td> <td>00 Hex</td> </tr> <tr> <td>5</td> <td>00 Hex</td> </tr> <tr> <td>6<sub>(LSB)</sub></td> <td>00 Hex</td> </tr> </tbody> </table>	Byte	Value	Description	1	03 Hex	Transmitter n. 3	2	24 Hex	Write calibration	3 <sub>(MSB)</sub>	00 Hex	Store calibration	4	00 Hex	5	00 Hex	6 <sub>(LSB)</sub>	00 Hex											
Byte	Value	Description																												
1	03 Hex	Transmitter n. 3																												
2	24 Hex	Write calibration																												
3 <sub>(MSB)</sub>	00 Hex	Store calibration																												
4	00 Hex																													
5	00 Hex																													
6 <sub>(LSB)</sub>	00 Hex																													



## 10. Profinet/EthernetIP messages

Message	Meaning
<i>Fbus_Er</i>	No connection received from module Hub after 30 second since system start
<i>F.r.HH.YY</i>	Firmware version of the module hub
<i>F_b_Conn</i>	Start the communication between hub module and scale
<i>F_b_oH</i>	Communication on fieldbus network configurated and running
<i>F_b_Err+code</i>	Error state, see table error codes
<i>F.bus.in</i>	Fieldbus initialization

Table error code:

Code	Meaning
1000	Fatal error in hub module
1001	Inconsistency between protocol type selected and the one managed by the Hub module, eg. Hub type DeviceNet module with Devicenet protocol selected on DGT1
1-18	Other fatal error in Hub module
000001 and the following	Unrecoverable error module Hub

Some error of network:

Code	Meaning
000140	General network error
000141	Connection closed
000142	Time-out connection
000143	Isolated network
000144	Duplicated node
000145	Network cable disconnected

## 11. Annunciators

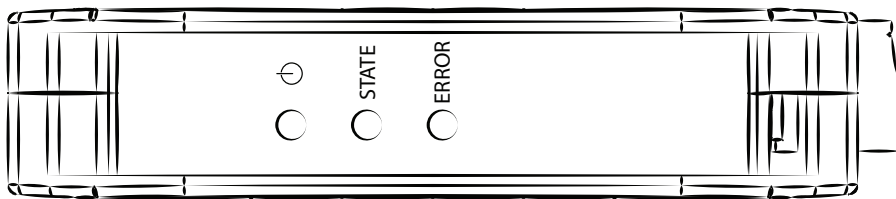

	When it flickers: fieldbus module initialization. When turned on: fieldbus module is ready.
	This LED indicates the RS485 communication state between fieldbus module and weight transmitter: When turned on: initialization of the communication. When it flickers: fieldbus module is correctly communicating. When it flickers slowly: fieldbus module is trying to communicate with the weight transmitter (no communication).
	When turned off: communication OK. When turned on or it flickers: no communication with the fieldbus master; check the cable connection, protocol and the PLC configuration.

**i**

All leds turn on during the fieldbus module start-up, allowing you to check their correct functioning.







**HEAD OFFICE**

Via Della Fisica, 20  
41042 Spezzano di Fiorano, Modena - Italy  
Tel. +39.0536 843418 - Fax. +39.0536 843521  
info@diniargeo.com

**SERVICE ASSISTANCE**

Via Dell'Elettronica, 15  
41042 Spezzano di Fiorano, Modena - Italy  
Tel. +39.0536 921784 - Fax. +39.0536 926654  
service@diniargeo.com

Authorized service center stamp

