

# Aviator 7000/5000

Service Manual

GB

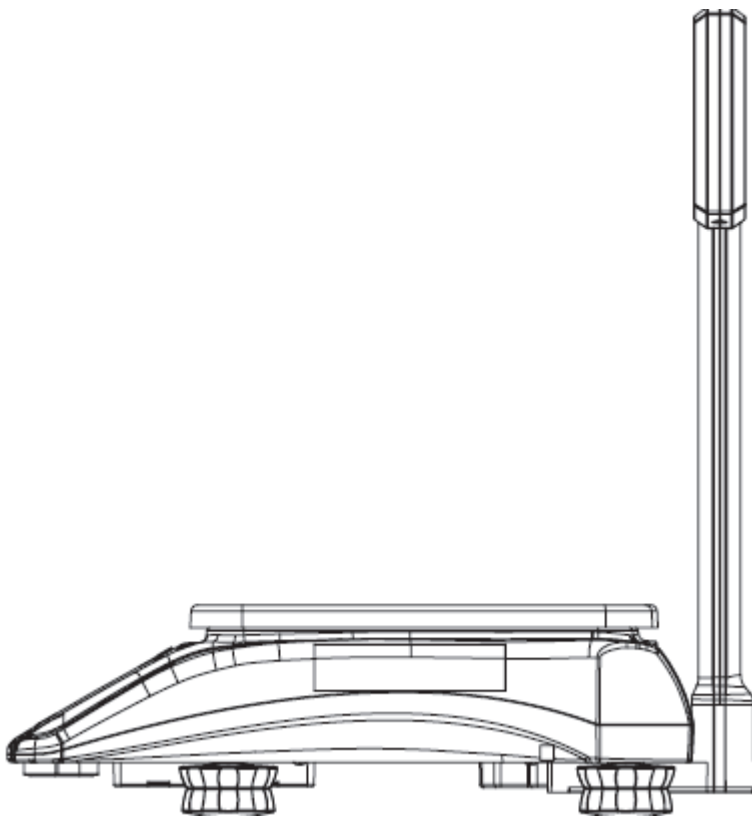

## Dimensions:

### Compact version:

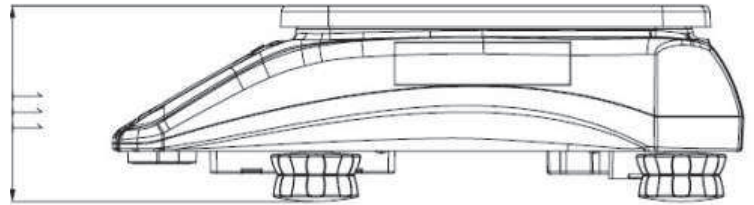
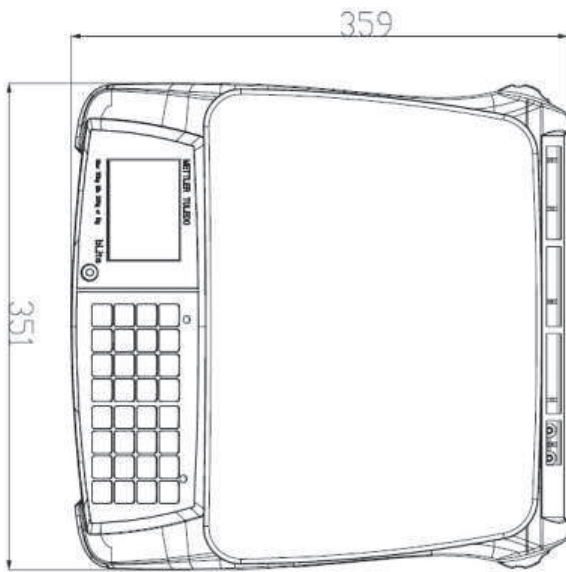

### Tower version:

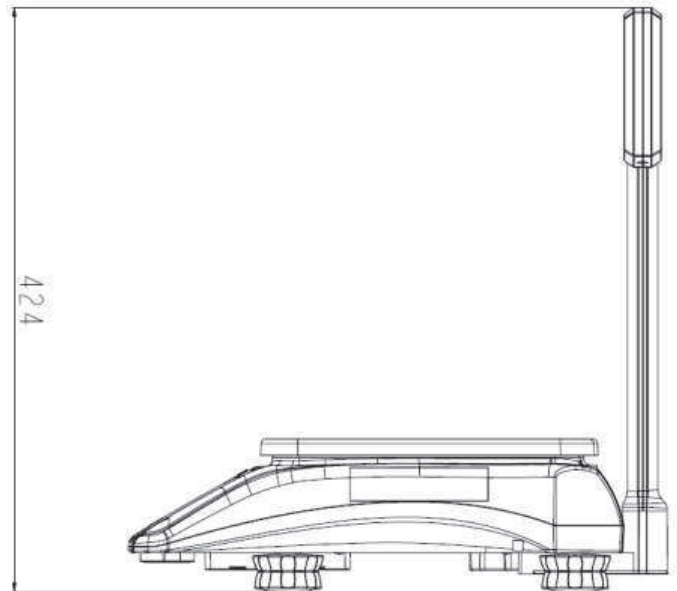
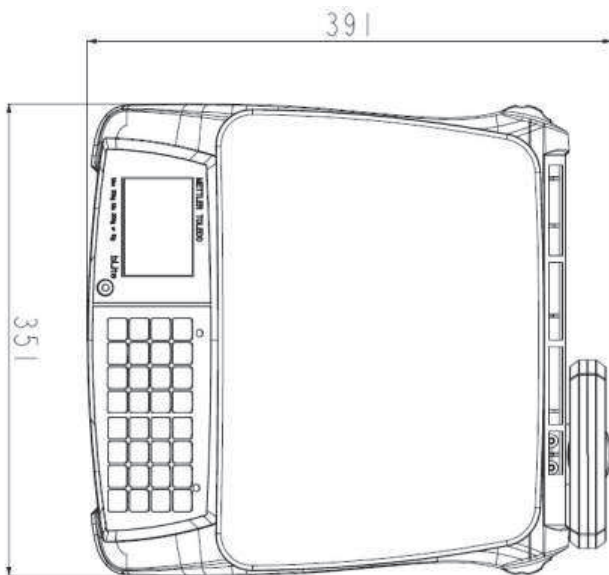

## **INTRODUCTION**

This publication is provided solely as a guide for individuals who have purchased the OHAUS Aviator scale product.

OHAUS<sup>®</sup>, Inc. 2010

No part of this manual may be reproduced or transmitted in any form or by any means, electronic or mechanical, including photocopying and recording, for any purpose without the express, written permission of Ohaus, Inc.



**OHAUS RESERVES THE RIGHT TO MAKE REFINEMENTS OR  
CHANGES WITHOUT NOTICE.**

## Precautions

READ this manual BEFORE operating or servicing this equipment.

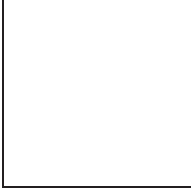

	<p> <b>WARNING</b></p> <p>ONLY PERMIT QUALIFIED PERSONNEL TO SERVICE THIS EQUIPMENT. EXERCISE CARE WHEN MAKING CHECKS, TESTS AND ADJUSTMENTS THAT MUST BE MADE WITH POWER ON. FAILING TO OBSERVE THESE PRECAUTIONS CAN RESULT IN BODILY HARM.</p>
---	--

FOLLOW these instructions carefully.

	<p> <b>WARNING</b></p> <p>FOR CONTINUED PROTECTION AGAINST SHOCK HAZARD, CONNECT TO A PROPERLY GROUNDED OUTLET ONLY. DO NOT REMOVE THE GROUND PRONG.</p>
---	---

STORE this manual for future reference.

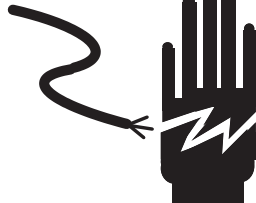
DO NOT allow untrained personnel to operate, clean, inspect, maintain, service, or tamper with this equipment.

	<p> <b>WARNING</b></p> <p>DISCONNECT ALL POWER TO THIS UNIT BEFORE REMOVING THE FUSE OR SERVICING. FAILURE TO DO SO MAY RESULT IN BODILY INJURY OR PROPERTY DAMAGE.</p>
--	--

ALWAYS DISCONNECT this equipment from the power source before cleaning or performing maintenance.

<p> <b>CAUTION</b></p> <p>BEFORE CONNECTING/DISCONNECTING ANY INTERNAL ELECTRONIC COMPONENTS OR INTERCONNECTING WIRING BETWEEN ELECTRONIC EQUIPMENT ALWAYS REMOVE POWER AND WAIT AT LEAST THIRTY (30) SECONDS BEFORE ANY CONNECTIONS OR DISCONNECTIONS ARE MADE. FAILURE TO OBSERVE THESE PRECAUTIONS COULD RESULT IN DAMAGE TO OR DESTRUCTION OF THE EQUIPMENT OR BODILY HARM.</p>	
--	--

Call OHAUS for parts, information, and service.

	<p> <b>CAUTION</b></p> <p>OBSERVE PRECAUTIONS FOR HANDLING ELECTROSTATICALLY SENSITIVE DEVICES.</p>
---	---



## GEO-Value

The GEO-Value of verified balances explains for which usage location the balance has been verified. This GEO-Value is shown on the balance total price display shortly after the balance is turned on.

Further details are shown in the "GEO-Value table" below.

## GEO-Value Table

Country	Geo-Width	Geo-Value (default)
Austria	46°22' – 49°01'	18
Belgium	49°30' – 51°30'	20
Bulgaria	41°41' – 44°13'	16
Croatia	42°24' – 46°32'	18
Czech Republic	48°34' – 51°03'	20
Denmark	54°34' – 57°45'	23
France	41°20' – 51°00'	19
Finland	59°48' – 70°05'	25
Germany	47°00' – 55°00'	20
Greece	34°48' – 41°45'	15
Hungary	45°45' – 48°35'	19
Ireland	51°05' – 55°05'	22
Iceland	63°17' – 67°09'	26
Italy	35°47' – 47°05'	17
Latvia	55°30' – 58°04'	23
Luxembourg	49°27' – 50°11'	20
Liechtenstein	47°03' – 47°14'	18
Lithuania	53°54' – 56°24'	22
Netherlands	50°46' – 53°32'	20
Norway	57°57' – 71°11'	24
Poland	49°00' – 54°30'	21
Portugal	36°58' – 42°10'	15
Romania	43°37' – 48°15'	18
Sweden	55°20' – 69°04'	24
Switzerland	45°49' – 47°49'	18
Slovakia	47°44' – 49°46'	19
Slovenia	45°26' – 46°35'	18
Spain	36°00' – 43°47'	15
Turkey	35°51' – 42°06'	16
United Kingdom	49°00' – 62°00'	21

## Table of Contents

<b>1. Introduction</b> .....	<b>7</b>
1.1. Overview.....	7
1.2. Service Facilities.....	7
1.3. Tools & Test equipment required.....	7
1.4. System Specifications.....	8
1.4.1. Aviator 5000.....	8
1.4.2. Aviator 7000.....	8
1.5. Model Configuration.....	9
1.6. Approval Documentation.....	9
1.7. Accessories.....	9
1.8. Sealing.....	10
1.9. Keyboard.....	11
1.9.1. Aviator 5000 Keyboard.....	11
1.9.2. Aviator 7000 Keyboard.....	11
1.10. Battery.....	12
<b>2. Installation</b> .....	<b>13</b>
2.1. Safety Precautions.....	13
2.2. Ambient Conditions.....	13
<b>3. Entering Operator Configuration Setup</b> .....	<b>13</b>
3.1. Setup Navigation.....	14
3.2. Entering Operational Setup.....	15
3.3. Entering Scale Configuration Setup.....	18
3.4. Time & Date Settings (Aviator 7000 only).....	20
3.5. Country Default Configuration.....	20
3.6. External peripheral printer (Not available in all countries) **.....	23
3.7. Calibration.....	24
<b>4. Maintenance</b> .....	<b>26</b>
4.1. Preventive Maintenance.....	26
4.2. Troubleshooting.....	26
4.3. Error Shooting.....	27
4.4. Diagnosis.....	28
<b>5. Replacing parts</b> .....	<b>28</b>
5.1. Service Preparation.....	28
5.2. Opening of the Housing.....	29
5.3. Replacing the Main Board.....	29
5.4. Load Cell.....	31
5.5. Display Exchange.....	33
5.6. Keyboard Exchange.....	34
<b>6. Appendix1</b> .....	<b>35</b>
<b>7. Appendix2</b> .....	<b>50</b>

# 1. Introduction

## 1.1. Overview

Target customers for Aviator are:

- Small store businesses
- Open Markets

All our equipment is assembled, tested and packed with great care. If you find that aspects of our quality do not meet your expectations, please contact OHAUS immediately.

Aviator scales are high-precision weighing instruments, which are approved and certified by weights and measures authorities. This scale is certified in our production plant or by your local weights & measures office. Please check the certification stickers on the scale before use.

Read this service manual carefully.

If properly used and maintained, the scale will provide years of accurate weighing. Please handle it as you would any piece of precision electronic equipment.

The information contained in this manual is believed to be accurate at the time of publication, but OHAUS assumes no liability arising from the use or misuse of this material. Reproduction of this material is strictly prohibited. Material in this manual is also subject to change.

© Copyright 2010 OHAUS, all rights reserved.  
TM Registered trademark of OHAUS.

## 1.2. Service Facilities

To service a scale, the service area should meet the following requirements:

- Should be temperature controlled and meet scale specifications for ambient temperature requirements.
- Must be free of vibrations, such as fork lift trucks close by large motors, air currents or drafts from air conditioning/heating ducts, open windows, people walking by, fans, etc.
- Area must be clean and free of excessive dust.
- Work surface must be stable and level.
- Scale must not be exposed to direct sunlight or radiating heat sources.
- Use an approved electro-static device.

## 1.3. Tools & Test equipment required

- Common hand tools are sufficient to disassemble Aviator price computing scales.

### Metrological instructions



Important legal note-for-trade scales in EEC countries



Factory-verified scales carry this identification on the label applied on the package.



Scales identified by the green "M" label applied on the identification plate can be operated immediately.



Scales calibrated in two stages carry the opposite identification on the label applied on the package

These scales have already been verified in the first step (declaration of conformity according to EN 45501-8.2) and should receive the second step at their place of use.

This second step must be performed by the certified OHAUS after-sales service.

Please contact your local OHAUS agency.

Retail scales, used for legal trade, must be submitted for calibration and verification.

Please respect and observe the current metrological directives in your country.

## 1.4. System Specifications

Aviator family consists of two products lines: Aviator 5000 and 7000

- The specifications of the Aviator are listed in the below table.
- After servicing the scale, the below specifications must be met.

### 1.4.1. Aviator 5000

Model	Aviator-A51P15L	Aviator-A51P12L
* Capacity	15kg/5g	12kg/2g
Load cell capacity	22kg	22kg
Display	LCD with backlight; 6-digit weight, 6-digit unit price, 6-digit total price	
Key	32 membrane keys	
Preset key	16 keys; one key can store one PLU (no double layer presets)	
Stainless pan	240 x 337 mm (trapezoid shape)	
PLU quantity	50	
Power	100~240VAC, 50/60HZ or 6VDC/4.5Ah lead-acid rechargeable battery (option)	
Gross weight / net weight	Gross weight: 6.10kg; Net weight: 4.20kg	
Shipping box (L x W x H)	480mm x 465mm x 180mm	
Working environment	Temperature: -10C~40C; Humidity: 85%RH, non-condensation	
Storage environment	Temperature: -25C~50C; Humidity: 85%RH, non-condensation	
Weighing function	Zero, Tare, 100g*, change*, Hold*, Euro*, 1/2lb*, 1/4lb*, kg/lb*	
Communication	None	
Software update	Through RS-232	

### 1.4.2. Aviator 7000

Model	Aviator-A71P3N	Aviator-A71P6TN	Aviator-A71P15 (T) N	Aviator-A71P12N	Aviator-A71P30N
* Capacity	3kg/1g	6kg/2g	15kg/5g	12kg/2g	30kg/10g
Load cell capacity	5kg	11kg	22kg	22kg	40kg
Display	LCD with backlight; 6-digit weight, 6-digit unit price, 7-digit total price, 4-digit tare display				
Key	32 light touch keys				
Preset key	16 keys, every key can store 2 PLUs				
Stainless pan	240 x 337 mm (trapezoid shape)				
PLU quantity	100				
Power	100~240VAC, 50/60HZ or 6 NIMH or D-cell batteries				
Gross weight / net weight	Tower version: Gross weight: 5.54 kg; Net weight: 3.73 kg Compact version: Gross weight: 5.23 kg; Net weight: 3.42 kg				
Shipping box (L x W x H)	480mm x 465mm x 180mm				
Working environment	Temperature: -10C~40C; Humidity: 85%RH, non-condensation				
Storage environment	Temperature: -25C~50C; Humidity: 85%RH, non-condensation				
Weighing function	Zero, Tare, 100g, charge*, Hold*, Euro*, 1/2lb*, 1/4lb*, kg/lb*				
Communication	RS232/USB				
Software update	Through RS-232				

\* Not available in all countries.



## 1.5. Model Configuration

### Aviator-A X1 PXX X X X (country code)

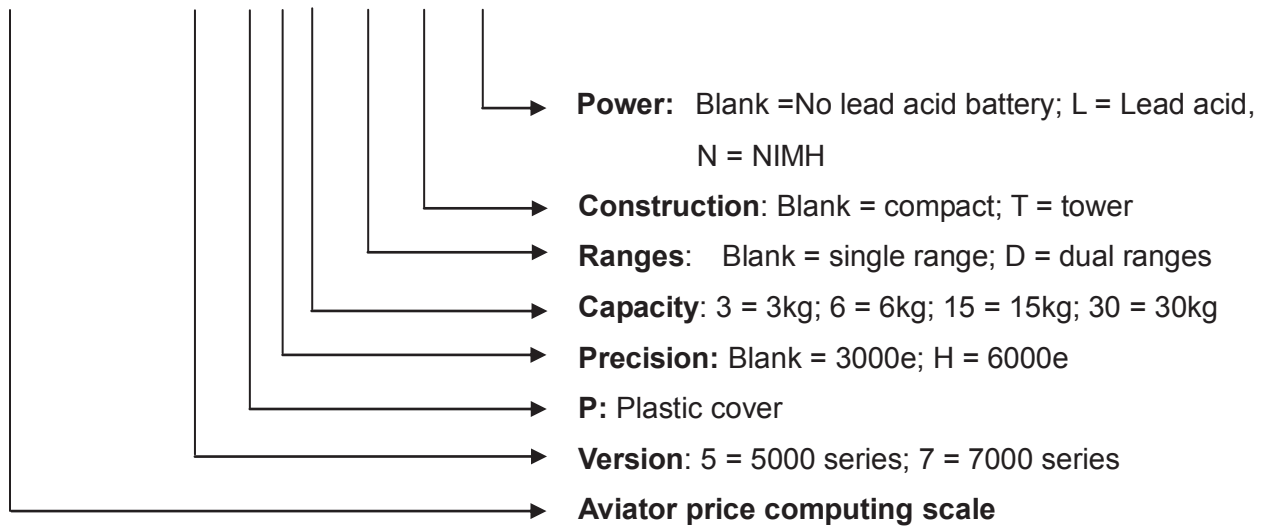

## 1.6. Approval Documentation

- OIML
- CE
- NTEP
- FCC
- UL
- CB

## 1.7. Accessories

Description	CIMF number
Lead acid rechargeable battery	72168359
NIMH rechargeable battery (6 pcs)	72151831
Plastic cover for pan	72247039
Plastic cover for housing	72247038
External Printer (Not available in all countries)	72248934
Ticket (Not available in all countries)	72181866
RS232 cables	72237981
USB cables	72237984

## 1.8. Sealing

After installation is completed, legal-for-trade applications require that the enclosure is sealed with a sticker. Metrological relevant settings can't be adjusted without breaking the sealing.



**Attention:**

Assuming the user is to use the (non-automatic) scales/balance in the legally regulated field, the user will be responsible for notifying the appropriate calibration authorities of the repaired scales/balance, so that the latter can take the appropriate measures (calibration/recalibration).

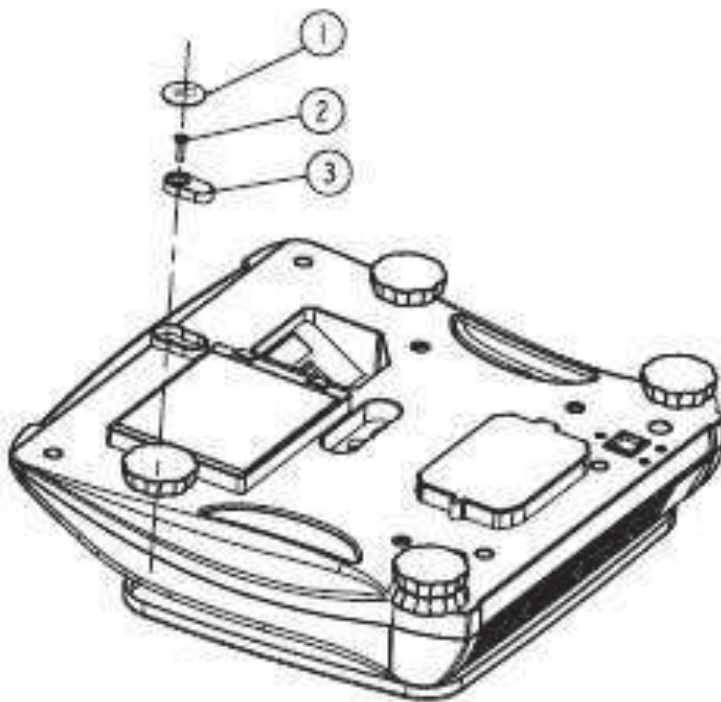

1. Sealing sticker
2. Sealing screw
3. Sealing cover

## 1.9. Keyboard

Keyboard layouts by region:

### 1.9.1. Aviator 5000 Keyboard

Europe's keyboard

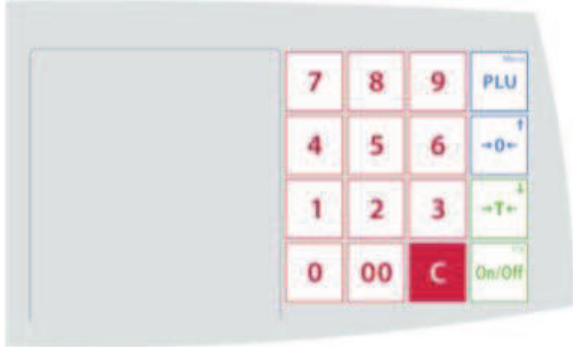

Europe's preset card



Americas & other countries' keyboard



America's Preset Card



Other Countries' Preset Card



### 1.9.2. Aviator 7000 Keyboard

Europe's keyboard



America's keyboard



America's keyboard

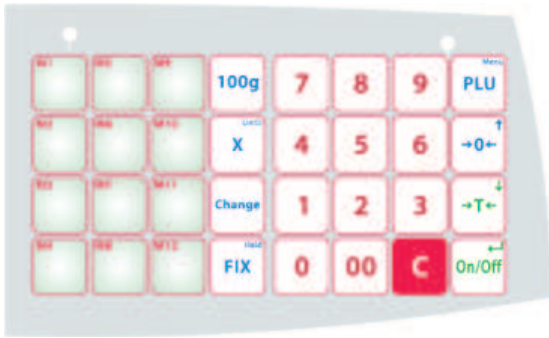

Other countries' keyboard



## 1.10. Battery

Aviator 5000 Series can only use lead acid batteries. Aviator 7000 Series can be operated by using NIMH and D-cell batteries.

- **Aviator 5000: Lead acid battery, 6V 4.5 Ah rechargeable battery**
- **Aviator 7000: NIMH battery, 1.2 V 7000 mAh rechargeable battery**

**Aviator 7000** provides the alternative to use NIMH and D-cell batteries.



When using rechargeable batteries. The battery switch located on the bottom side of the device needs to be switched to NimH. Default position of switch is NimH as indicated on picture. If the switch is in this position (as indicated on the below drawing) **ONLY** rechargeable NIMH battery of size UM1 should be used.

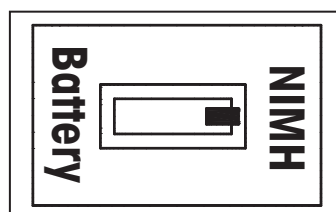

If you want to use D-Cell, push the switch to the D-cell side. In this status, charging function is disabled automatically.

## 2. Installation

Before installing your Aviator scale, identify the best location for your new equipment. A suitable installation environment enhances operation and ensures a long life of the scale. Keep in mind the following factors, which might have a negative influence on the scale's performance:

- Vibration diminishes the scale's ability to measure accurately. Excessive vibration from equipment such as conveyors can cause inaccurate and non-repeatable readings.
- Be sure the scale is leveled properly.
- Air currents can also diminish a scale's performance.
- Avoid placing the scale in front of or directly under air vents.
- Other than items being weighed, avoid any objects rubbing or pressing against any part of the scale.

### 2.1. Safety Precautions

In order to prevent accidents at work, the installer is required to take actions, directions and measures that comply with the general regulations for the prevention of industrial accidents, all other valid regulations for the prevention of accidents and with all other generally recognized regulations relating to safety and occupational health.

### 2.2. Ambient Conditions

The right location is critical to weighing accuracy. Ideal locations comply with the following conditions:

- No shocks and vibrations.
- No excessive temperature fluctuations.
- No direct sunlight.
- Select a vibration-free location for your scale.

## 3. Entering Operator Configuration Setup

Modification of operational setup parameters will allow adjusting the functionality of the system to working requirements.

Enter Setup:

1. When unit price is 0, Press the Manu key for around 3 seconds.
2. After hearing a long beep, the display will show "SET 1 OP".
3. Push ON/OFF key to enter operator configuration.

### 3.1. Setup Navigation

The system is structure in 5 major setup categories:

- Set 1: Operational Setup
- Set 2: Scale Configuration Setup
- Set 3: Calibration Setup
- Set 4: Precision measurement (manufacturing)
- Set 5\*: Date & Time Setup

\* Only for Advanced line.

Setup Navigation keys:

Aviator 5000



Aviator 7000



Enter Setup & Leave Setup\*



Enter Setup Group & Select the Parameters



Go up



Go down

\* Leave Setup:

Go back to the first level manual when you press menu key one time; when you press this key two times, you can choose SAVE or ABORT all parameters which you set.

## 3.2. Entering Operational Setup

1. When unit price is 0, Press the Menu key for around 3 seconds.
2. After hearing a long beep, the display will show "SET 1 OP".
3. Press ON/OFF key to enter the Operational Setup Group.

### Operational Settings Summary:

#### Aviator 5000 Series:

Step	Function	Explanation	Default
1	Initialize to Defaults (only for operation configuration)	ON: Initialize softswitch parameters to the defaults	
		OFF: Scale will not initialize scale softswitch parameters	X
2	Buzzer	OFF: No sound when a key is pressed	
		ON: Strong volume when key is pressed	X
3	Backlight	OFF: No backlight	X
		ON: Strong backlight	
4	Automatic power off and Total power off time	0: Disable both sleep & power off function	
		1: No sleep function, auto power off after 30 Minutes of non-use	
		2: Sleep function after 5 minutes of non-use; no auto power off	
		3: Sleep function after 5 minutes of non-use, Auto power off after 30 minutes of non-use	
		4: Sleep function after 15 minutes of non-use, no auto power off	
5	Auto-clear of Tare and Unit	ON: Enables automatic clearing when weight is removed from platter	X
		OFF: Disables automatic clearing when the weight is removed from platter	
6	Prepack / Fix Mode Enable	ON: Enables Prepack/Fix mode	X
		OFF: Disables Prepack/Fix mode	
7	Auto PLU	ON: Search PLU automatically	
		OFF: Search PLU after depressing the PLU key	X
8	Digital Filter Selection	0: Light digital filtering	
		1: Medium digital filtering	X
		2: Heavy digital filtering.	
9	Charge	ON: Enable battery charge	X
		OFF: Disable battery charge	
10	Function keys	0 = Total Function keys are disabled	X
		1 = Total Function keys are enabled	
11	PLU Enable	ON: Enables the storage of unit price	X
		OFF: Disables this feature	
12	By-Count/X Mode Enable	ON: By-count pricing is enabled	X
		OFF: By-count pricing is disabled	
13	EURO Phase **	1= Phase 1	X
		2= Phase 2	
		3= Phase 3	
		4= Phase 4	

\*\* Only available in specific regions

**Aviator 7000 Series:**

Step	Function	Explanation	Default
1	Initialize to Defaults (only for operation configuration)	ON: Initialize softswitch parameters to the defaults	
		OFF: Scale will not initialize scale softswitch parameters	X
2	Buzzer	OFF: No sound when a key is pressed	
		ON: Strong volume when key is pressed	X
3	Backlight	OFF: No backlight	X
		ON: Strong backlight	
4	Automatic power off and Total power off time	0: Disable both sleep & power off function	
		1: No sleep function, auto power off after 30 Minutes of non-use	
		2: Sleep function after 5 minutes of non-use; no auto power off	
		3: Sleep function after 5 minutes of non-use, Auto power off after 30 minutes of non-use	
		4: Sleep function after 15 minutes of non-use, no auto power off	
5: Sleep function after 15 minutes of non-use, Auto power off after 30 minutes of non-use	X		
5	Auto-clear of Tare and Unit	ON: Enables automatic clearing when weight is removed from platter	X
		OFF: Disables automatic clearing when the weight is removed from platter	
6	Prepack / Fix Mode Enable	ON: Enables Prepack/Fix mode	X
		OFF: Disables Prepack/Fix mode	
7	Auto PLU	ON: Search PLU automatically	
		OFF: Search PLU after depressing the PLU key	X
8	Digital Filter Selection	0: Light digital filtering	
		1: Medium digital filtering	X
		2: Heavy digital filtering.	
9	Charge	ON: Enable battery charge	X
		OFF: Disable battery charge	
10	Function keys	0 = Total Function keys are disabled	
		1 = Total Function keys are enabled	X
11	PLU Enable	ON: Enables the storage of unit price	X
		OFF: Disables this feature	
12	By-Count/X Mode Enable	ON: By-count pricing is enabled	X
		OFF: By-count pricing is disabled	
13	EURO Phase **	1= Phase 1	X
		2= Phase 2	
		3= Phase 3	
		4= Phase 4	
14	Two PLU in one preset key	ON: Two PLUs can be preset in one preset key	X
		OFF: Only one PLU can be pre-set in one preset key	
15	Communication Port	0: RS232	X
		1: USB	
16	Communication Type **	0: Protocol	X
		1: Printer	
17	Ticket Language **	0 = English	X
		1 = French	
		2 = Germany	
		3 = Spanish	
		4 = Italian	
18	RS232 Communication Speed	0= 1200bps	
		1= 2400bps	
		2= 4800bps	
		3= 9600bps	X
		4= 19200bps	



		5= 38400bps	
		6= 57600bps	
19	Data bits, Parity, Stop bits	0= 7, Even, 1	
		1= 7, Odd, 1	
		2= 7, No, 1	
		3= 8, No, 1	X
		4= 7, Even, 2	
		5= 7, Odd, 2	
		6= 7, No, 2	
		7= 8, No, 2	
20	Protocol	0= CAS (Price computing)	
		1= Avery Berkel (Price computing)	
		2= Dialog 06 (Price computing)	X
		3= L2 Mettler Toledo (Price computing)	
		4= Anker (Price computing)	
		5= Dialog 02/04 (Price computing)	
		6= NCI_Protocol (Price computing)	
21	VAT **	ON= Price is with VAT	X
		OFF=Price is without VAT	
22	VAT key **	0= VAT key disable	X
		1= VAT key enabled	
23	PLU Tare Enable	ON: Enables storage of tare with the unit price*	X
		OFF: Disables this feature	

\* Depending on geography default is on or/off

\*\* Not available in all countries

### 3.3. Entering Scale Configuration Setup

1. When unit price is 0, Press the Manu key for around 3 seconds.
2. After hearing a long beep, the display will show "SET 1 OP".
3. Press the Tare key to go down to set 2, then press ON/OFF key.
4. Display messages: Press Seal.
5. Break the sealing located under the scale. Press the calibration button to enter the configuration, display will show: STEP 1.

**For more information on settings & scale functionality, please refer to below form.**

#### Aviator 5000 Series:

Step	Function	Explanation
1	Country	Detail in the section "specification by country"
2	Initialize to Defaults	YES: Initialize softswitch parameters to the defaults NO: Scale will not initialize scale softswitch parameters
3	Display comma or period	OFF: Use a "." in all weight and price data ON: Use a "," in all weight and price data
4	Decimal Point Position Select for Price Displays	Select the number of the digits (0, 1, 2, and 3) to be displayed to the right of the decimal point for the unit price and total price displays
5	No Content	
6	Enable Zero Cursor	ON: Enables zero cursor OFF: Disables zero cursor
7	Gross or Net Zero	ON: Zero cursor will be illuminated when the gross or net OFF: Zero cursor will be illuminated when the gross weight
8	Display uuuuu's When	ON: Show uuuuu's when weight is less than zero OFF: Show negative weight when under zero
9	Tare Enable	ON: Enables tare function OFF: Disables tare function
10	Chain Tare	Enable ON: Enables chain (multiple) tares OFF: Only one tare per transaction is allowed
11	Keyboard Tare Enable	ON: Tare can be entered via scale numeric keyboard OFF: The steady weight on the platter becomes the tare
12	Keyboard Tare Clear	ON: Tare can be cleared when the platter is empty OFF: Tare can not be cleared via the keyboard
13	Accumulate/+ Enable	ON: Enables Accumulator OFF: Disables Accumulator
14	Change Function Enable	ON: Enable change function OFF: Disable change function
15	Total Price Round	ON: Total price will be rounded OFF: Total price not round
16	Unit price multiplication	ON: Enable this function OFF: Disable this function
17	Hold function	ON: Enable this function OFF: Disable this function
18	1/2LB or 100g pricing	ON: Enable 1/2lb or 100g function OFF: Disable 1/2lb or 100g function
19*	1/4LB pricing enable	ON: Enable 1/4 lb function OFF: Disable 1/4 lb function
20*	Switch between LB & KG	ON: Enable this function OFF: Disable this function

\* Only available in specific regions

**Aviator 7000 Series:**

Step	Function	Explanation
1	Country	Detail in the section "specification by country"
2	Initialize to Defaults	YES: Initialize softswitch parameters to the defaults NO: Scale will not initialize scale softswitch parameters
3	Display comma or period	OFF: Use a "." in all weight and price data ON: Use a "," in all weight and price data
4	Decimal Point Position Select for Price Displays	Select the number of the digits (0, 1, 2, and 3) to be displayed to the right of the decimal point for the unit price and total price displays
5	Currency *	0= no currency 1= € 2= Fr. 3= Kr 4= \$ 5= £ 6= Rs 7= Zt 8 = T
6	Enable Zero Cursor	ON: Enables zero cursor OFF: Disables zero cursor
7	Gross or Net Zero	ON: Zero cursor will be illuminated when the gross or net OFF: Zero cursor will be illuminated when the gross weight
8	Display uuuuu's When	ON: Show uuuuu's when weight is less than zero OFF: Show negative weight when under zero
9	Tare Enable	ON: Enables tare function OFF: Disables tare function
10	Chain Tare	Enable ON: Enables chain (multiple) tares OFF: Only one tare per transaction is allowed
11	Keyboard Tare Enable	ON: Tare can be entered via scale numeric keyboard OFF: The steady weight on the platter becomes the tare
12	Keyboard Tare Clear	ON: Tare can be cleared when the platter is empty OFF: Tare can not be cleared via the keyboard
13	Accumulate/+ Enable	ON: Enables Accumulator OFF: Disables Accumulator
14	Change Function Enable	ON: Enable change function OFF: Disable change function
15	Total Price Round	ON: Total price will be rounded OFF: Total price not round
16	Unit price multiplication	ON: Enable this function OFF: Disable this function
17	Hold function	ON: Enable this function OFF: Disable this function
18	1/2LB or 100g pricing	ON: Enable 1/2lb or 100g function OFF: Disable 1/2lb or 100g function
19	1/4LB pricing enable *	ON: Enable 1/4 lb function OFF: Disable 1/4 lb function
20	Switch between LB & KG *	ON: Enable this function OFF: Disable this function

\* Not available in all countries

### 3.4. Time & Date Settings (Aviator 7000 only)

1. Access Setup menu as described above
2. Press arrow up or down to set the time.
  - a. Year configuration: Press up or down arrow key to choose the accurate year. Then press on/off key.
  - b. Month configuration. Also use up or down arrow key to choose the digit. On/Off key to enter the Day setting process.
  - c. Day configuration: Same as year and month adjustment process.

\*

### 3.5. Country Default Configuration

Country	G E O	Country type	S1	S2		S3	S4	S5	S6
			Country	Initialize To Defaults	Ticket Lang	Display comma or period	Decimal Point Position Select for Price Displays	Currency	Enable Zero Cursor
China	12	3	CN	1		.	2		1
Germany	20	0	DE	1	German	,	2	€	0
France	19	0	FR	1	French	,	2	€	0
USA	12	2	US	1	English	.	2	\$	1
Austria	18	0	AT	1	German	,	2	€	0
Spain/ Portugal	15	0	ES	1	Spanish	,	2	€	0
Belgium/ Netherlands	21	0	BE	1	French	,	2	€	0
Italy	17	0	IT	1	Italian	,	2	€	0
Swiss	18	0	CH	1	German	,	2	Fr.	0
Ukraine	21	3	UA	1	English	,	2		0
Russia	23	3	RU	1	English	,	2		0
Hungary	19	1	HU	1	English	.	0		0
Slovakia	19	1	SK	1	English	,	2	€	0
Czechia	20	1	CZ	1	English	,	1		0
Poland	21	1	PL	1	English	,	2	Zł	0
slovenia	18	0	SLO	1	English	,	2	€	0
Croatia	18	0	HR	1	English	,	2	€	0
England	21	3	GB	1	English	,	2	£	0
Kazakhstan	18	3	KZ	1	English	,	2	T	0
India	12	3	IN	1	English	,	2	Rs	1
Turkey	14	3	TR	1	English	.	2	TL	0
E-Port	12	3	E-Port	1	English	.	1	€	0

Country	G E O	Country type	S7	S8	S9	S10	S11	S12	S13
			Gross or Net Zero	Display uuuuu's When	Tare Enable	Chain Tare	Keyboard Tare Enable	Keyboard Tare Clear	Accumula te/+ Enable
China	12	3	0	0	1	1	0	0	1
Germany	20	0	0	0	1	1	1	1	0
France	19	0	0	0	1	1	1	1	0
USA	12	2	0	0	1	1	1	1	1
Austria	18	0	0	0	1	1	1	1	0
Spain/ Portugal	15	0	0	0	1	1	1	1	0
Belgium/ Netherlands	21	0	0	0	1	1	1	1	0
Italy	17	0	0	0	1	1	1	1	0
Swiss	18	0	0	0	1	1	1	1	0
Ukraine	21	3	0	0	1	1	1	1	0
Russia	23	3	0	0	1	1	1	1	0
Hungary	19	1	0	0	1	1	1	1	0
Slovakia	19	1	0	0	1	1	1	1	0
Czechia	20	1	0	0	1	1	1	1	0
Poland	21	1	0	0	1	1	1	1	0
slovenia	18	0	0	0	1	1	1	1	0
Croatia	18	0	0	0	1	1	1	1	0
England	21	3	0	0	1	1	1	1	0
Kazakhstan	18	3	0	0	1	1	1	1	0
India	12	3	0	0	1	1	0	1	1
Turkey	14	3	0	0	1	1	1	1	1
E-Port	12	3	0	0	1	1	0	1	0

Country	G E O	Country type	S14	S15	S16	S17	S18	S19	S0
			Change Function	Total Price Round	Unit price multiplicat ion	Hold function	1/2lb or 100g pricing	1/4Lb pricing enable	switch on kg/lb
China	12	3	1	0	1	1	1	0	0
Germany	20	0	1	0	1	0	1	0	0
France	19	0	1	0	1	0	1	0	0
USA	12	2	1	0	1	1	1	1	1
Austria	18	0	1	0	1	0	1	0	0
Spain/ Portugal	15	0	1	0	1	0	1	0	0
Belgium/ Netherlands	21	0	1	0	1	0	1	0	0
Italy	17	0	1	0	1	0	1	0	0
Swiss	18	0	1	1	1	0	1	0	0
Ukraine	21	3	1	0	1	0	1	0	0
Russia	23	3	1	0	1	0	1	0	0
Hungary	19	1	1	0	1	0	1	0	0
Slovakia	19	1	1	0	1	0	1	0	0
Czechia	20	1	1	0	1	0	1	0	0
Poland	21	1	1	0	1	0	1	0	0
slovenia	18	0	1	0	1	0	1	0	0
Croatia	18	0	1	0	1	0	1	0	0
England	21	3	1	0	1	0	1	0	0
Kazakhstan	18	3	1	0	1	0	1	0	0
India	12	3	1	0	1	1	1	0	0
Turkey	14	3	1	0	1	1	1	0	0
E-Port	12	3	1	0	1	1	1	0	0

**Table descriptions:**

**Setting meaning:**

0= OFF 1= ON

**County type is used for country area definition:**

- 0: West Europe
- 1: East Europe (only this country type has EUR function)
- 2: USA and Canada
- 3: Others

**3.6. External peripheral printer (Not available in all countries) \*\***

**How to connect the printer to scale:**

- Plug the printer power cable to socket.
- Use printer cable to connect the scale  
(RJ45 is connect with scale, RS232 is used for connecting with printer)

\* Please be aware that all transaction data is lost if the mainboard is exchanged.



OHAUS does not take over any liabilities that come up due to the connection of printers not officially recommended by OHAUS for the concerned product line. **Printers connected to the system & not officially recommended by OHAUS might not be covered by the scale approval.** Get in contact with OHAUS to obtain information about which peripheral printers are listed as officially supported products

Scale Memory: Up to 500 data sets can be stored on the system. Once the system reaches memory limits the oldest data record will be canceled automatically.

**Ticket data English**

**Ticket Layout Example**

1. Date & time & Ticket Number
2. PLU Text
3. kg (Pcs)
4. (Local currency)/kg (PCS)
5. PLU Number/ Non PLU text
6. Total
7. Tax
8. Change/Change

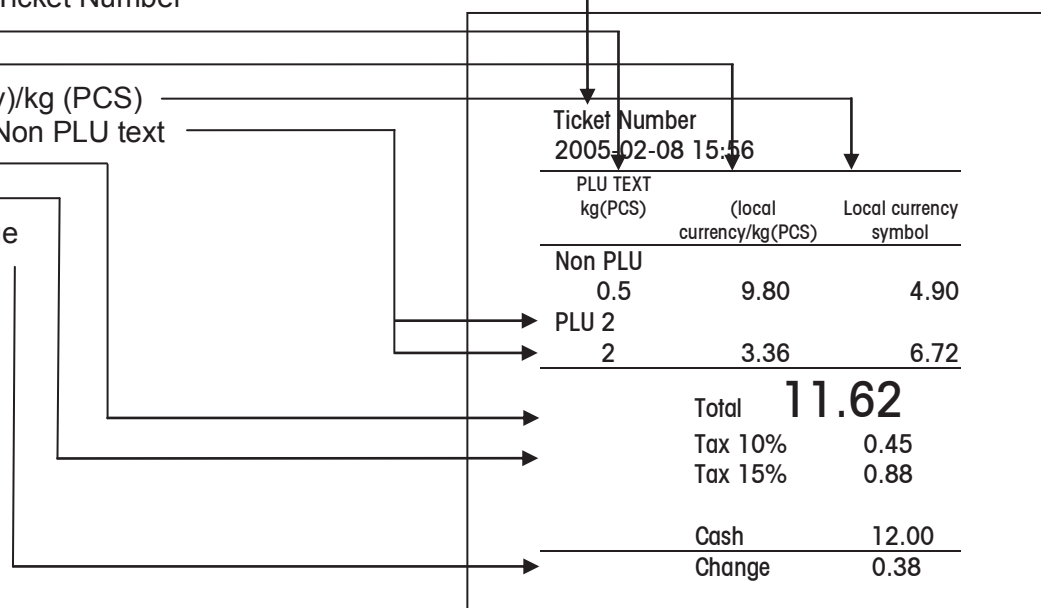

### 3.7. Calibration

#### Important Note:

Assuming the user is to use the (non-automatic) scales/balance in the legally regulated field, the user will be responsible for notifying the competent calibration authorities of the repaired scales/balance, so that the latter can take the appropriate measures (calibration/recalibration).

#### Capacity and Increments

Weight unit	Resolution	Capacity (kg)	Increment (g)	Capacity of the load cell (kg)	Load Cell BOM
Kg	3000	3	1	5	72184999
		6	2	11	72186986
		15	5	22	72186876
		6/15	2/5	22	72184997
		30	10	40	72186879
	6000	12	2	22	72186875
		30	5	40	72186878

\* Offering dependent on geography

#### Calibration switch position:

The calibration switch is located in the base of the scales – next to the adapter housing.  
Please use a thin rod to press the calibration switch when system displays message “Press seal”.

#### Steps when breaking the seal:

1. Break the paper seal and unscrew the plastic cover fixation.
2. Take off the plastic cover.
3. Press the calibration switch with a thin rod.

#### Calibration steps:

Procedure	Description	Key operation	Display on 1st line	Display on 2nd line	Display On 3rd line	Display on the bottom line	Lit cursor
Step1	Weighing mode		0.000	0.00	0.00		
Step2		[Menu]				SET 1 OP	
Step3	Press T key until display show SET 3 CAL	[T]				SET 3 CAL	
Step4	Please press the calibration button	[on/off]				Press seal	
Step5	One beep indicate that the calibration button has been pressed, granting access to setup mode					SET	
Step6	Access to calibration setting	[on/off]				GEO	
Step7	Choose the accurate GEO	[T]				GEO ***	
Step8		[on/off]	CAL				
Step9	Choose Y to access to calibration setting	[T]	CAL Y				
Step10	Choose unit kg or lb	[on/off]	KG				
Step11	Choose ranges single or dual	[on/off]	sing				
Step12		[on/off]	CAP		precision		
Step13	Select the capacity	[T]	CAP		precision		
Step14	Capturing zero	[T]	-----				
Step15	Count down from 5 to 0 and go to next step automatically. If scale is not stable, will show 5 and not count down to find zero	[on/off]	5				



Procedure	Description	Key operation	Display on 1st line	Display on 2nd line	Display On 3rd line	Display on the bottom line	Lit cursor
Step16	Put the weight on the platter (*valid weight is about 2/3 capacity)		Add **				
Step17	Count down from 5 to 0	[on/off]				Capture 0	
Step18	Choose save or abort calibrations	[T]	save				
Step19	Finish, and then turn on	[on/off]					

## 4. Maintenance

### 4.1. Preventive Maintenance

OHAUS scales are precision instruments which should be handled carefully, stored in a clean, dry, dust-free area, and cleaned periodically. Follow these precautionary steps:

- When a scale has had chemicals or liquids spilled on it, all exterior surfaces should be cleaned as soon as possible with warm water on a damp cloth.
- Do not leave any weights on the scale when the scale is not in use.
- Allow time for the scale to stabilize after moving it from an area which is at a different temperature than the area where it is to be operated. Allow one hour for each 5°F (2.7°C) temperature change before using the scale. After temperature stabilization, allow an additional 20 minutes after turning the scale on, for the scale electronics to stabilize.

#### Preventive Maintenance Checklist

The scale should be inspected and checked regularly as follows:

- Clean the outside of the scale using a damp cloth with warm water.

#### CAUTION:

DO NOT USE CHEMICAL CLEANERS OR SOLVENTS OF ANY TYPE. SOME CLEANERS ARE ABRASIVE AND MAY AFFECT THE SCALE'S FINISH.

- Check to ensure that the power cord is not broken and has no damaged insulation.
- If using batteries and the scale malfunctions, first replace the batteries to see if this resolves the problem.
- Make a visual inspection for faulty connectors, wiring, and loose hardware.

### 4.2. Troubleshooting

This section of the manual contains troubleshooting information. It includes information to isolate specific problems step by step. Before doing any such work, make certain that your working area is clean, that you handle all scale components with care, and that you use a suitable electro-static device.

#### Diagnostic Guide:

##### Scale inoperative/ blank displays

1. Check voltage on power supply. If voltage at outlet is zero, replace power supply.
2. Check whether the harnesses are properly connected.
3. Try to press the keyboard. If you can hear a beep while pressing the keyboard, replace the display. Otherwise please replace the mainboard.

##### Keyboard inoperative

1. Check keyboard connection on main board, ensuring it is securely plugged in.
2. If all connections are secure and keyboard is inoperative, replace keyboard.

##### Can't communicate via RS232 with peripheral printer (Print function is not available in all countries)

1. Check the scale version. Only Aviator 7000 has this function.
2. Check Operational setup parameters:
  - Communication port STEP 15 must be set to RS232
  - Communication type STEP 16 should be set to Printer
  - Check if Communication speed STEP 18 & Data Bits, STEP 19 are set to default settings
  - Check if a printer recommended by OHAUS for this scale is connected to the scale
  - Check if peripheral printer is switched on and has enough power
3. If all parameters are correct, please

- Replace the RS232 cable.
- Check printer functionality by trying to print a printer system status report. (See documentation printer)
- Replace the main board

### Print white paper

1. Check the harness, ensuring it is secure.
2. Replace the printer.
3. If it is still inoperative, replace mainboard.

### Can't communicate via RS232 or USB with POS system

1. Check the scale version. Only Aviator 7000 has this function.
2. Check Operational Setup parameters
  - Communication port STEP 15 must be set to RS232 or USB depending on the connection strategy. Make sure that the setting matches with the connector cable used to build the connection between scale & POS
  - Communication type STEP 16 should be set to Protocol
  - Verify whether the same communication protocol is selected on scale & POS (STEP 20 allows the selection of the protocol)
  - Verify if POS & printer are using recommended stop bits & communication speed, Verify whether stop bits & communication speed are the same on Pos & Scale (STEP 18,19)

### Weighing result not stable

1. Check load cell harness.
2. Check whether there is something touching the load cell.
3. Replace the AD board or load cell.

## 4.3. Error Shooting

Error messages indicate serious hardware malfunctions. The error table below lists error codes & their problem solutions.

Error	Reason	Solution
E11	RAM error	Call Ohaus service
E16	ROM error	
E18	EEPROM error	
No PLU	PLU not found	Program PLU
nnnnnn in weight display	Over capacity	Remove weight from Platter
uuuuuu in weight display	Negative weight	Re-zero the scale

## 4.4. Diagnosis

1. Isolate and identify the symptom.
2. Refer to the diagnostic guide and locate the symptom  
(Please also refer to the Troubleshooting chapter).
3. Follow the suggested remedies in the order they appear.
4. Perform the indicated checks, or refer to the appropriate section of the manual.
5. Repair or replace the defective section of the scale.

### NOTE:

If more than one symptom is observed, approach one area at a time, and remember that the symptoms may be interrelated.

If a problem arises that is not covered in this manual, contact us for further information.

## 5. Replacing parts

Before servicing the scale, always unplug the power cord from the scale.

Only qualified service staff may open the scale for service purposes.

Be aware of any static charges and wear a static-proof wrist belt when touching the PCB.

### 5.1. Service Preparation

Use the below procedures to replace the main board, display, load cell and keyboard.

#### Important Notice:

Assuming the user is to use the (non-automatic) scales/balance in the legally regulated field, the user will be responsible for notifying the appropriate calibration authorities of the repaired scales/balance, so that the latter can take the appropriate measures (calibration/recalibration).

After replacing the main board or parts used in the actual measurement process, the following steps must be performed:

- Check & set the local geo code setting (geo code for the region in which the product is to be used)
- Check calibration reproducibility, linearity, eccentricity
- Apply local currency/country setting

#### Preparations before opening the housing (if possible):

- Note settings (Country, Geo code, Decimal point)
- Verify installed SW version

#### The repair of the scale requires common hand tools:

## 5.2. Opening of the Housing

Important notice: **Please refer to the service preparations chapter before opening the housing.**

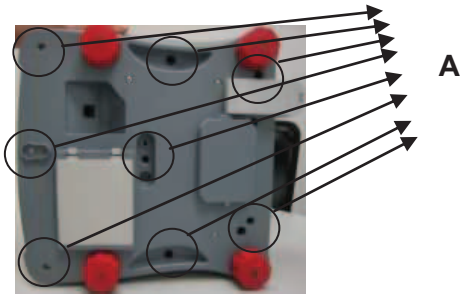

### Procedure for opening the housing:

1. Open the top cover. Unscrew the 8 bolts **A** (7 screws, 1 sealing screw).
2. Remove plastic cover carefully to not destroy keyboard or display connectors



When opening and removing the top housing, display & keyboard are still connected to the mainboard. The housing can only be opened by destroying the metrology sealing. Assuming the user is to use the (non-automatic) scales/balance in the legally regulated field, the user will be responsible for notifying the appropriate calibration authorities of the repaired scales/balance, so that the latter can take the appropriate measures (calibration/recalibration).

## 5.3. Replacing the Main Board

### Procedure for replacing the board:

1. Lift top cover (for details, please refer to Open housing chapter; please see also chapter service preparation).
2. Disconnect all cables plugged into main PCB.
3. Install the new PCB following the same instructions in reverse order.
4. Install the top cover.

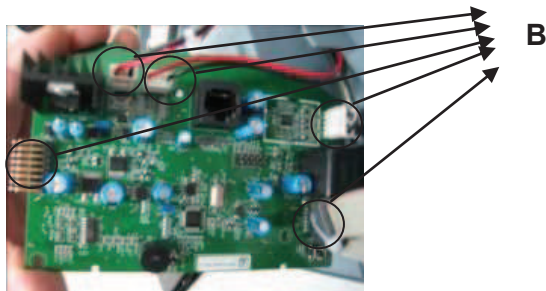

### Procedure for restoring the system

1. Define country code (Scale Configuration, STEP1).
2. Initialize to defaults (Operational Setup; STEP2).
3. Define & save all parameters (Press menu key 2 times and choose save).
4. Switch scale on again, check configuration (Geo Code & Country Setting) on the display while scale is booting.



After replacing the main board, the following steps must be performed:

- Check & set local geo code

- Apply local currency/country setting
- After changing the mainboard calibration of the system is mandatory

**Attention:**

Assuming the user is to use the (non-automatic) scales/balance in the legally regulated field, the User will be responsible for notifying the appropriate calibration authorities of the repaired scales/balance, so that the latter can take the appropriate measures (calibration/recalibration).

## 5.4. Load Cell

**Preparation:** Write down the geo code

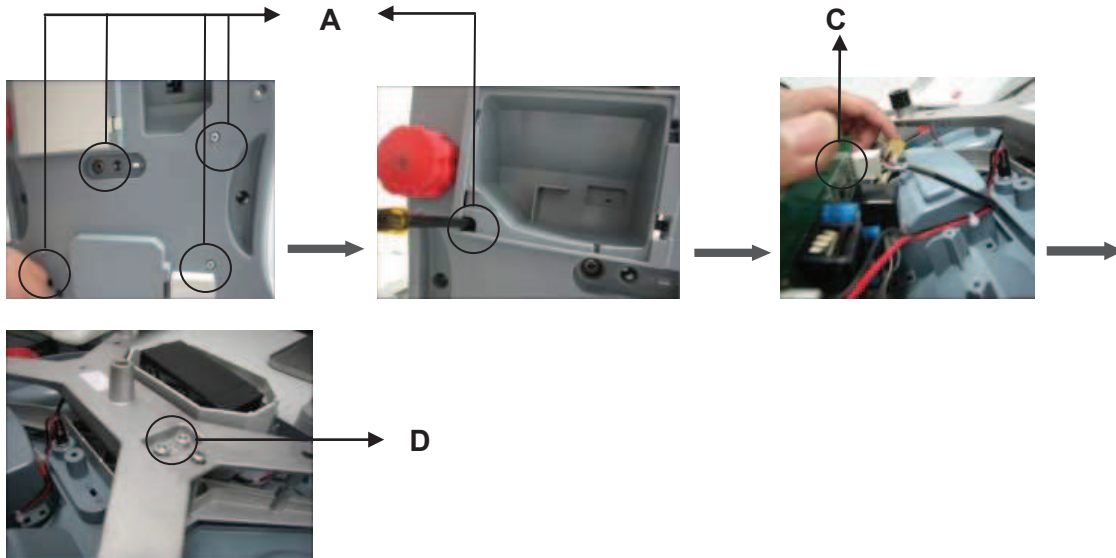

### Procedure for replacing the load cell:

1. Open top cover (More details please refer to open housing chapter, service preparations section).
2. Unscrew the four screws (A).
3. Open adapter housing and unscrew 1 screw (A).
4. Disconnect the load cell cable(C) from mainboard.
5. Remove 4 screws of the load cell support (D).Remove the old load cell.
6. Install the new load cell (**capacities lower than 7kg: 7.2N.m~7.8N.m; Capacities over 10kg: 10.5N.m~11.0N.m**), following the same instructions in the reverse order.
7. **Adjust the overload gap and underload gap to avoid damage to the load cell. Reference the below form.**

Product name	Tools	Capacity of LC	4 corner gap	Mid corner gap	Draw corner gap
Aviator	Q25-1	AMI-5kg	0.60+0.05mm	0.35+0.05mm	0.35mm
	Q25-2	AMI-11kg	0.7+0.05mm	0.40+0.05mm	0.35mm
	Q25-4	AMI-22kg	1.25+0.05mm	0.62+0.05mm	-----
	Q25-5	AMI-40kg	2.15+0.05mm	1.25+0.05mm	-----

8. Close housing.

### Attention:

Assuming the user is to use the (non-automatic) scales/balance in the legally regulated field, the User will be responsible for notifying the appropriate calibration authorities of the repaired scales/balance, so that the latter can take the appropriate measures (calibration/recalibration).

### Calibration testing procedures:

#### 1. Repeatability Test

**Purpose:** Determination of the difference between several weighing processes for one load.

**References:** R76-1 (legal for trade).

**Limits:**

<b>Levels</b>	All
<b>Max. error</b>	Delta Span $\leq$ 1 Mpe

<b>Weighing</b>	<b>Max. error</b>
0e<m<500e	$\leq$ 0.5e
500e<m<2000e	$\leq$ 1.0e
2000e<m<max	$\leq$ 1.5e

**Conditions:** standard conditions.

**Procedure:**

- 10 times individual weighing with full load (nearest the capacity). Position on the center of the plate
- 10 times individual weighing with 50% of full load (nearest the capacity).  
Position on the center of the plate.
- If necessary, repeat measurements with other loads and tare values.
- Measurements can be taken manually or automatically (computer test program or printer).
- In the case of a zero indication deviation between the weighing, the instrument shall be reset to zero without determining the error at zero.
- Record: indication of 3 individual weighing processes for each load, and time behavior of each weighing process.

**Results:**

Comparison of the indications with the required values, the highest and lowest indications for any given load should be within 1 mpe of each other.

**2. Linearity Test**

**Purpose:** Determination of the repeatability (deviation in multiple weighing processes of the same load), and of the linearity behavior of the EUT.

**References:** Product description.

<b>Weighing</b>	<b>Max. error</b>
0e<m<500e	$\leq$ 0.5e
500e<m<2000e	$\leq$ 1.0e
2000e<m<max	$\leq$ 1.5e

**Conditions:** standard conditions.

**Procedure:**

- 10 individual weighing processes at each load with at least 5 different loads (including zero point and full load). Suggested individual weighing with 0, 1/6, 1/3, 2/3, 1 of full load.
- When taking individual weight measurements at no load, tap the pan lightly to produce a visible change on the indicator. After the reading stabilizes, this indication is the zero or zero error reading for no load.
- Measurements can be taken manually or automatically (computer test program or printer).
- Recorded data: zero point and indication of 10 individual weighing processes at each load, and if necessary, the time behavior of each weighing process.

**Results:**

Comparison of the indications with the 10 individual weighing processes of each load, the highest and lowest indications for any given load should be within 1 mpe of each other.



## 5.5. Display Exchange

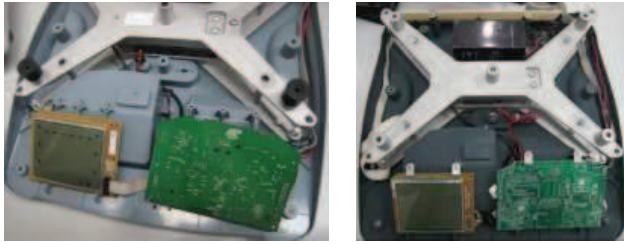

### Procedure for replacing the display:

#### *Replacing the operator side display*

1. Open the top cover (please refer to opening housing chapter, please see also service preparations section)
2. Disconnect all cables.
3. Remove the old display directly.
4. Install a new display, follow same instructions in the reverse order.

#### *Replacing the customer side display*

1. Open the top cover (please refer to the Opening the Housing chapter, service preparations section).
2. Disconnect all cables.
3. Remove the old display directly.
4. Install new display, follow same instructions in the reverse order.

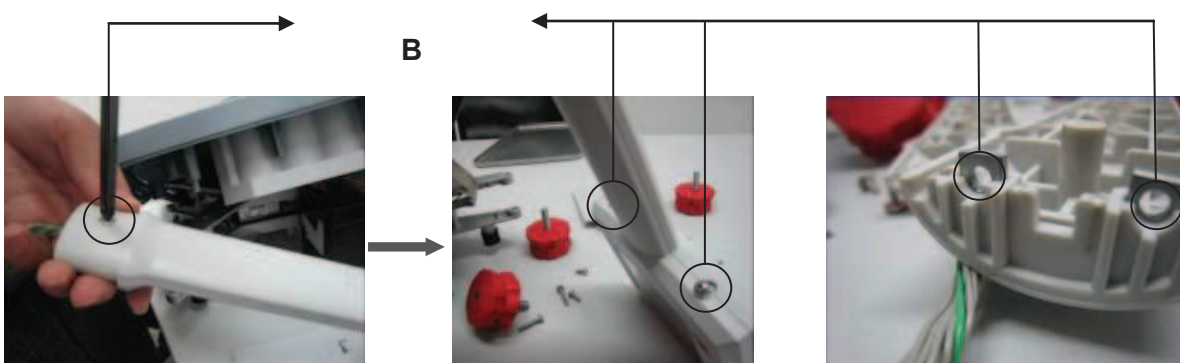
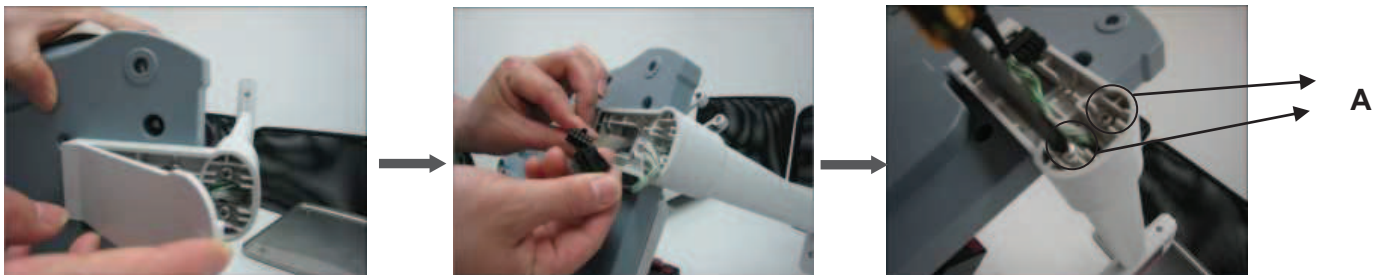

#### *Replacing the tower display.*

1. Reverse housing.
2. Open the tower base cover.
3. Disconnect cables.
4. Unscrew the 2 screws (A).
5. Unscrew the 3 screws (B) Please pay attention to that there are two screws in tower, be care, don't lost it when you open the tower.
6. Install a new display. Follow the same instructions in the reverse order.

## 5.6. Keyboard Exchange

Procedure for replacing the keyboard:

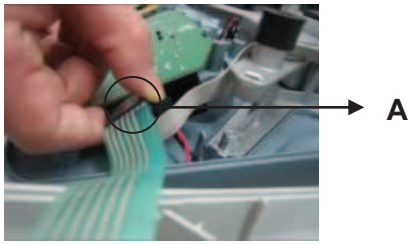

### *Replacing Aviator 5000 keyboard*

1. Open top cover (please refer to open the housing chapter, service preparations section).
2. Disconnect keyboard cable (A).
3. Remove the old keyboard
4. Install new keyboard, following the same instructions in the reverse order.

### *Replacing Aviator 7000 keyboard (PCB layer)*

1. Open top cover (please refer to opening housing chapter, service preparations section).
2. Take off silicon key layer/ function paper layer/ white silicone mat.
3. Disconnect keyboard cable (A).
4. Remove the old keyboard directly.
5. Install a new keyboard, following the same instructions in the reverse order

## **6. Appendix1**

### **6.1 Protocols**

For the Price Computing version, there are 7 different protocols. The numbers correspond to the number that will show up in the Softswitch settings:

0. CAS
1. Berkel
2. Dialog 06
3. L2 Mettler-Toledo
4. Anker
5. Dialog 02/04
6. NCI

#### **6.1.1 CAS**

##### **6.1.1.1 Data Format**

9600 Baud (select 2400, 4800 or 9600)

7 data bits (select 7 or 8)

Even parity (select Even, None or Odd parity)

1 stop bit (select 1 or 2 stop bit)

##### **6.1.1.2 Handshaking**

For PC DB25 serial port connector: Jumper 4 to 5, and 6, 8, & 20 together.

For PC DB9 serial port connector: Jumper 4 to 6 and 7 to 8.

##### **6.1.1.3 Command Descriptions**

Command	COMMENTS
ENQ (05h)	Starts the communication sequence
ACK (06h)	Data Available
NAK (15h)	No acknowledgement
DC1 (11h)	Data Request (Format 1, Weight Only)
DC2 (12h)	Data Request (Format 2, Total Price, Weight, and Unit Price)
STX (02h)	Start of text
STA	Status – “S” when stable, U when unstable
Sign	Space (20h) when zero or positive, “-”(2dh) when negative, “F” (46h) when overflow.
Weight	6 bytes with MSD first and including decimal: W4W3.W2W1W0
Weight Units	2 bytes for weight units (i.e. Kg) following Weight data
Price	8 bytes with MSD first and including decimal: P6P5P4P3P2.P1P0 Spaces are used for leading non-significant digits, i.e. a price of 15.00 would be transmitted as “ 15.00” with four leading spaces.
Unit Price	8 bytes with MSD first and including decimal: U6U5U4U3U2.U1U0 Spaces are used for leading non-significant digits, i.e. a price of 15.00 would be transmitted as “ 15.00” with four leading spaces.
BCC	Block Check Character calculated as the even column parity (Longitudinal Redundancy Check) of all characters except the STX and ETX.
ETX (03h)	End of text
EOT (04h)	End of transmission

### 6.1.1.4 Command Flow

#### Format 1

ECR	Scale	COMMENTS
ENQ (05h)		
	ACK (06h)	Data Available. Errors could be: NAK - no acknowledgement
DC1 (11h)		Data Request Errors could be: NAK – no acknowledgement
	SOH STX STA SIGN W4W3.W2W1W0 kg BCC ETX EOT	Transmitted Data

#### Format 2

ECR	Scale	COMMENTS
ENQ (05h)		
	ACK (06h)	Data Available. Errors could be: NAK - no acknowledgement
DC2 (11h)		Data Request Errors could be: NAK – no acknowledgement
	SOH STX P6P5P4P3P2.P1P0 BCC ETX STX STA SIGN W4W3.W2W1W0 kg BCC ETX STX U6U5U4U3U2.U1U0 BCC ETX EOT	Transmitted Data

**Note:** Spaces depicted in the description above are only used for ease of reading.

## 6.1.2 Berkel

### 6.1.2.1 Data Format

2400 Baud (select 2400, 4800 or 9600)

7 data bits (select 7 or 8)

Even parity (select Even, None or Odd parity)

1 stop bit (select 1 or 2 stop bit)

### 6.1.2.2 Handshaking

For PC DB25 serial port connector: Jumper 4 to 5, and 6, 8, & 20 together.

For PC DB9 serial port connector: Jumper 4 to 6 and 7 to 8.

### 6.1.2.3 Command Descriptions

Command	COMMENTS																			
ENQ (05h)	Starts the communication sequence																			
ACK (06h)	Data Available																			
CAN (18h)	Repeat weighing																			
NAK (15h)	No acknowledgement																			
NUL (00h)	No data available																			
DC1 (11h)	Data Request																			
STX (02h)	Start of text																			
ID	Information byte, broken down into the following bits: <table border="1" style="margin-left: auto; margin-right: auto;"> <thead> <tr> <th colspan="3">Bit</th> <th rowspan="2">Capacity</th> </tr> <tr> <th>2</th> <th>1</th> <th>0</th> </tr> </thead> <tbody> <tr> <td>0</td> <td>0</td> <td>1</td> <td>15kg x 0.005kg</td> </tr> <tr> <td>0</td> <td>1</td> <td>0</td> <td>30lb x 0.01lb</td> </tr> <tr> <td>0</td> <td>1</td> <td>1</td> <td>6kg x 0.002kg</td> </tr> </tbody> </table> <p> <b>Bit 3</b> - Logic 1  <b>Bit 4</b> - Logic 1 means under/over range  <b>Bit 5</b> - Logic 1  <b>Bit 6</b> - Logic 1 indicates non-AVR capacities           </p>	Bit			Capacity	2	1	0	0	0	1	15kg x 0.005kg	0	1	0	30lb x 0.01lb	0	1	1	6kg x 0.002kg
Bit			Capacity																	
2	1	0																		
0	0	1	15kg x 0.005kg																	
0	1	0	30lb x 0.01lb																	
0	1	1	6kg x 0.002kg																	
Weight	5 bytes with MSD first																			
BCC	Block Check Character calculated as the even column parity (Longitudinal Redundancy Check) of all characters except the STX and ETX.																			
ETX (03h)	End of text																			
STX Z NUL NUL NUL NUL NUL ETX BCC	Command String to Zero the scale from the EPOS, note that the BCC in this case will be "Z"																			
STX N NUL NUL NUL NUL NUL ETX BCC	Command String to Tare the scale from the EPOS, note that the BCC in this case will be "N"																			
CR (0dh)	Data received and compared correctly																			

### 6.1.2.4 Command Flow

ECR	Scale	COMMENTS
ENQ (05h)		
	ACK (06h)	Data Available. Errors could be: CAN - repeat weighing NAK - no acknowledgement NUL - no data available
DC1 (11h)		Data Request Errors could be: NAK – no acknowledgement
	STX ID W5W4W3W2W1 BCC ETX	Transmitted Data
STX ID W5W4W3W2W1 BCC ETX		Confirm Data Errors could be: ACK – Data not confirmed
	CR (0dh)	Data confirmed

**Note:** Spaces depicted in the description above are only used for ease of reading. No space characters are used unless the BCC result yields the space character.

### 6.1.3 Dialog 06

With free programmable POS-Systems it is for a third party on principle possible, to manipulate parts of the software, which are obligate to verification.

For this reason certifying agencies expects appropriate protection against such inadmissible manipulations of third parties.

A protection against manipulations presents the Checkout-Dialogue 06 in conjunction with precautions taken at the POS-Software.

#### 6.1.3.1 POS-Software

The parts of the POS-Software, which are obligated to verify, have to be protected with checksums (here called value CS), created by an appropriate method (for instance CRC16). These checksums CS have also to be protected with checksums (here called value KW), created by the CRC16-method in use with a polynomial P, which is known only by the manufacturers of the scale and the POS-system. CS and KW both have a length of 16 bit.

REMARK: KW REPRESENTS THE REST OF THE POLYNOMIAL-DIVISION  $CS / P$ .

#### 6.1.3.2 Checkout-Dialogue 06

The checkout-dialogue 06 presents for the scale the possibility, to request 1-5 pairs of values CS/KW in cyclic intervals from the POS-system and check their validity. In case of invalidity, no weight-results will be given from the scale to the POS-system, i.e. dealing with the scale is not possible. With the request for the checksums, the scale sends a random number, which has to be used from the POS-system for encoding the checksums. This shall prevent a third party from monitoring valid checksums with simple measures. The random number is an 8-bit-number, the higher nibble (here called Z1) is used for encoding the CS-values, and the lower nibble (here called Z2) is used for encoding the KW-values. The encoding of the CS-values has to be made by rotating them to the left for Z1 bits, the encoding of the KW-values by rotating them to the right for Z2 bits.

For checking the conformity of the used protocol version in POS-system and scale, the Checkout-Dialogue 06 presents for the POS-system the possibility to order the scale to display the version number of the protocol. If the POS-system also displays the version number, the conformity can be checked.

### 6.1.3.3 Command Descriptions

#### Records for Communications from a POS system to the Scale

<b>Record 01: Transmitting of unit price</b>
<b>EOT STX 01 ESC D5 D4 D3 D2 D1 D0 ESC ETX</b> \            /            / Record No.                    Unit price 5/6 digits
<b>Record 03: Transmitting of unit price and tare value</b>
<b>EOT STX 03 ESC D5 D4 D3 D2 D1 D0 ESC T3 T2 T1 T0 ETX</b> \            /            /            / Record No.                    Unit price 5/6 digits                    Tare value 4 digits
<b>Record 04: Transmitting of unit price and text (TLU)</b>
<b>EOT STX 04 ESC D5 D4 D3 D2 D1 D0 ESC A.....A ETX</b> \            /            /            / Record No.                    Unit price 5/6 digits                    Text 13 chars
<b>Record 05: Transmitting of unit price, tare value and text (TLU)</b>
<b>EOT STX 05 ESC D5 D4 D3 D2 D1 D0 ESC T3 T2 T1 T0 ESC A.....A ETX</b> \            /            /            /            / Record No.                    Unit price 5/6 digits                    Tare value 4 digits                    Text 13 chars
<b>Record 08: Status request after receiving &lt;NAK&gt;</b>
<b>EOT STX 08 ETX</b> \ Record No.
<b>Record 10: Transmitting of checksums</b>
<b>EOT STX 10 ESC CS1 KW1 CS2 KW2 .. CSn KWn ETX</b> \            /            /            /            / record            pair 1            pair 2            .....            pair n No.                    CS/KW Checksums must be transmitted as hexadecimal ASCII-chars. Max. of "n" is 5. Example: CS1 = 74AEH-> 37H, 34H, 41H, 45H ('7','4','A','E')
<b>Record 20: Version number on / off</b>
<b>EOT STX 20 ESC D0 ETX</b> \            / record                            30H = off No.                                    31H = on
<b>Record 80: Display of piece article (weight display inactive)</b>
<b>EOT STX 80 ESC A.....A ESC P5 P4 P3 P2 P1 P0 ESC B5 B4 B3 B2 B1 B0 V ETX</b> \            /            /            /            /            / record            text            price display            amount display            sign No.                    21 chars            (6 digits or spaces)            (6 digits (Comma will be inserted))            ('-' or '+') displaying of a piece article will be ended with - Another Record 80, or Records 81, 01, 03, 04, or 05.
<b>Record 81: Deletion of piece article (weight display active)</b>
<b>EOT STX 81 ETX</b> \ Record No.
<b>Request for weight</b>
<b>EOT ENQ</b> scale answers with record 02
<b>Resetting of scale interface</b>
<b>EOT</b>

## Records for Communications from the Scale to a POS system

**Record 02:** Result of weighing (answer to records 01, 03, 04, 05)

STX	02	ESC	X	ESC	D4	D3	D2	D1	D0	ESC	D5	D4	D3	D2	D1	D0	ESC	D5	D4	D3	D2	D1	D0	ETX
	∖				∖						∖						∖							
	Record		status		scale-weight						unit price						price to pay							
	No.				5 digits						5/6 digits						6 digits							

Scale status  
 30H = lb. : oz / 1/8 oz  
 31H = lb. / 0,01  
 32H = lb. / 0,005  
 33H = kg

**Record 09:** Status information (answer to Record 08)

STX	09	ESC	S1	S0	ETX
	∖		∖		
	Record				
	No.				

00	no error
01	general error
02	parity error or buffer overflow
10	invalid record no.
11	invalid unit price
12	invalid tare value
13	invalid text
20	scale is still in motion (no standstill)
21	scale wasn't in motion since last operation
22	measurement is not yet finished
30	weight is less than minimum weight
31	scale is less than 0
32	scale is overloaded

**Record 11:** Request of checksums (or answer to Record 10)

STX	11	ESC	D0	Z	ETX
	∖		∖		
	Record				
	No.				

random number (only if D0 = 32H)  
 30H = checksums invalid  
 31H = checksums valid  
 32H = answer with rec. 10, use random number Z

Representation of random number Z like checksums (hexadecimal ASCII-char)

### 6.1.3.4 Description of the Dialog

A dialogue will always be initiated by the POS-system.

#### Description of weighing operation

The POS-system transmits one of the **Records 01, 03, 04 or 05**.

The scale answers (if no errors) with **ACK** and displays the transmitted data. The POS-system now can request the weighing result from the scale by transmitting **EOT ENQ**. If the result is known the scale answers with **Record 02**.

If there is an error, the scale answers with **NAK**. The cause of the error can be explained by the POS-system sending **Record 08** and receiving **Record 09**. If the status is 20 or 22, the weighing results can be requested again by retransmitting **EOT ENQ**. In the case of other errors, the operation has to be started at the beginning (records 01, 03, 04 or 05).

#### Description of weighing operation with request of checksums

At certain times, the scale will request from the POS-system the calculation and transmitting of checksums. This will happen in the course of a weighing operation after receiving of one of the records 01, 03, 04 or 05, and happens if one of the following events occurs:

- the scale was just powered on
- there was an error detected before
- 50 weighing operations have taken place
- the version number was displayed by the scale (record 20)



- Order of events:
  - The POS-system transmits one of the **Records 01, 03, 04 or 05**.
  - The scale answers with **Record 11**.
  - Example: STX 11 ESC 247 ETX (transmit record 10, use random number 47H)
  - The POS-system now calculates the checksums, encodes and transmits them by **record 10** to the scale.
  - The scale responds Record 10 first with **ACK**.
  - The POS-system continues as with a normal weighing operation by transmitting **EOT ENQ**.
- Only now the scale responds the validity of the checksums by **Record 11**.
- If the checksums were valid, the scale transmits STX 11 ESC 1 ETX otherwise STX 11 ESC 0 ETX.
- Regardless whether the response was positive or negative, the POS-system has to repeat the original weighing operation.

### Status information

The POS-system is able to get status information from the scale by record 08.

### Version number on/off

The POS-system can display the version number of the software in the scale. If the scale receives record 20 EOT STX 20 ESC 1 ETX, it will display the version number until it receives EOT STX 20 0 ETX. All other records will be ignored in between!

Please note that all dialogues must be initiated by the POS-system with **EOT**, **AND** also every response of the scale has to be answered by the POS-system with **EOT** !

## 6.1.4 L2 Mettler-Toledo

### 6.1.4.1 Connector and Data Format

Connector: 7-pin. Receptor (round)

Fa. Binder Series 680

Plug pin out RS232:

Pin 1 GND

Pin 2 RXD

Pin 5 TXD

RS232 scale communication parameter:

ASCII,

7 data bits,

1 stop bit,

1 start bit,

Parity - odd,

2400 baud

All data for this protocol is sent Most Significant Digit first.

All data is sent in ASCII format.

Examples:

Spaces have been added here for clarity, do not send spaces.

Set price to 1.23

G00123<CR><LF> = 0x47 0x30 0x30 0x31 0x32 0x33 0x0D 0x0A

Set Price to 1.23 with Tare value of 123g

G00123<CR><LF> = 0x47 0x30 0x30 0x31 0x32 0x33 0x54 0x30 0x31 0x32 0x33 0x0D 0x0A

## 6.1.4.2 Command Descriptions

Operation	P.O.S		Scale
Initialization and cancellation of a weighing procedure. (scale not ready, gross weight = 0 )	<ACK><CR><LF>	->	
		<-	<ACK><CR><LF>
Transmission price/unit	GXXXXX<CR><LF> (price)	-> or	
Together with the price/unit a tare value can be transmitted. Only tare values corresponding to the range of the scale can be transmitted.	GXXXXXTxxxx<CR><LF> (price, tare)	-> or	
Furthermore, an optional article text (TLU) can be transmitted. The article text has to be 14 characters long. Shorter texts have to be filled with blanks (Space) up to 14 characters. To display the letters? use following chars: [ = ? in display ] = ? in display \ = ? in display To display abbreviation letters (ex.: F.) use small letters. Ex.: f = F. in display	GXXXXXAAAAAAAAAAAAAAAA<CR><LF> (price, TLU)	-> or	
	GXXXXXTxxxxAAAAAAAAAAAAAAAA<CR><LF> (price, tare, TLU)	->	
1. Answer for valid weighing result		<-	XXXXX<SP>XXXXXX<CR><LF> (weight amount)
2. Answer, if temporarily not ready (scale in motion, or gross weight = 0) Scale sends this command in a 300 ms cycle, until scale is ready to send the weighing result. Afterwards weight and amount is being sent. During this time, the scale is not ready to receive !		<-	D<CR><LF>
3. Answer for invalid weighing result <ul style="list-style-type: none"> <li>▪ weight &lt; 2d</li> <li>▪ overload/underload</li> <li>▪ weight negative</li> <li>▪ no movement &gt; 5d happened</li> </ul>		<-	<NAK><CR><LF>
Transmission error of scale	E<CR><LF>	->	
		<-	nothing
Transmission error of P.O.S Note: In this case scale shows "Err 10". Please cycle power to the scale.		<-	E<CR><LF>
	nothing	->	

### 6.1.4.3 Flow Chart

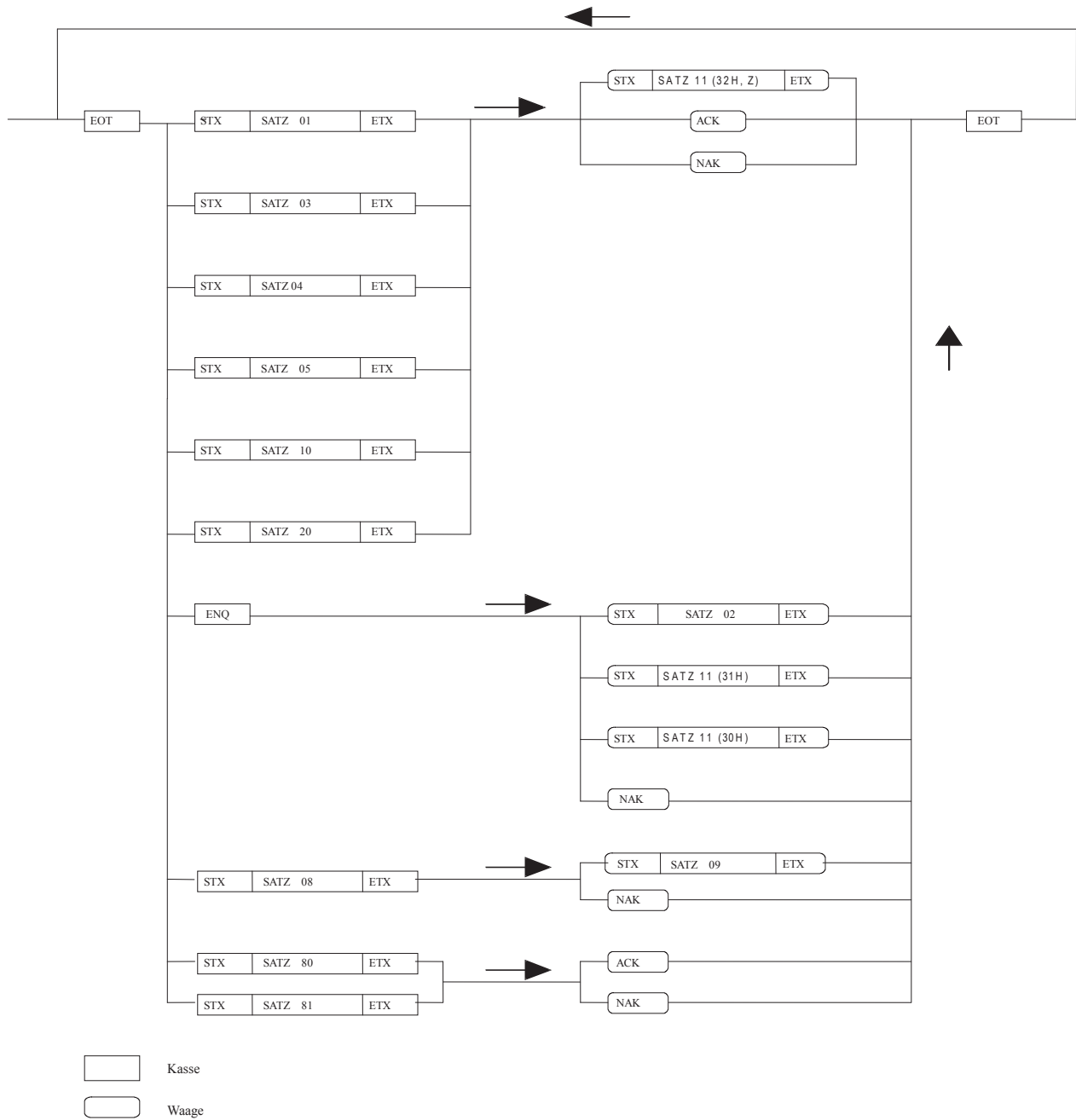

### 6.1.4.4 Data Format

Baud rate: 9600 Baud

Type of transmission: asynchronous

Data format: 7 Bit + Parity

Parity: odd

Stop bit: 1 Bit

### 6.1.5 Anker

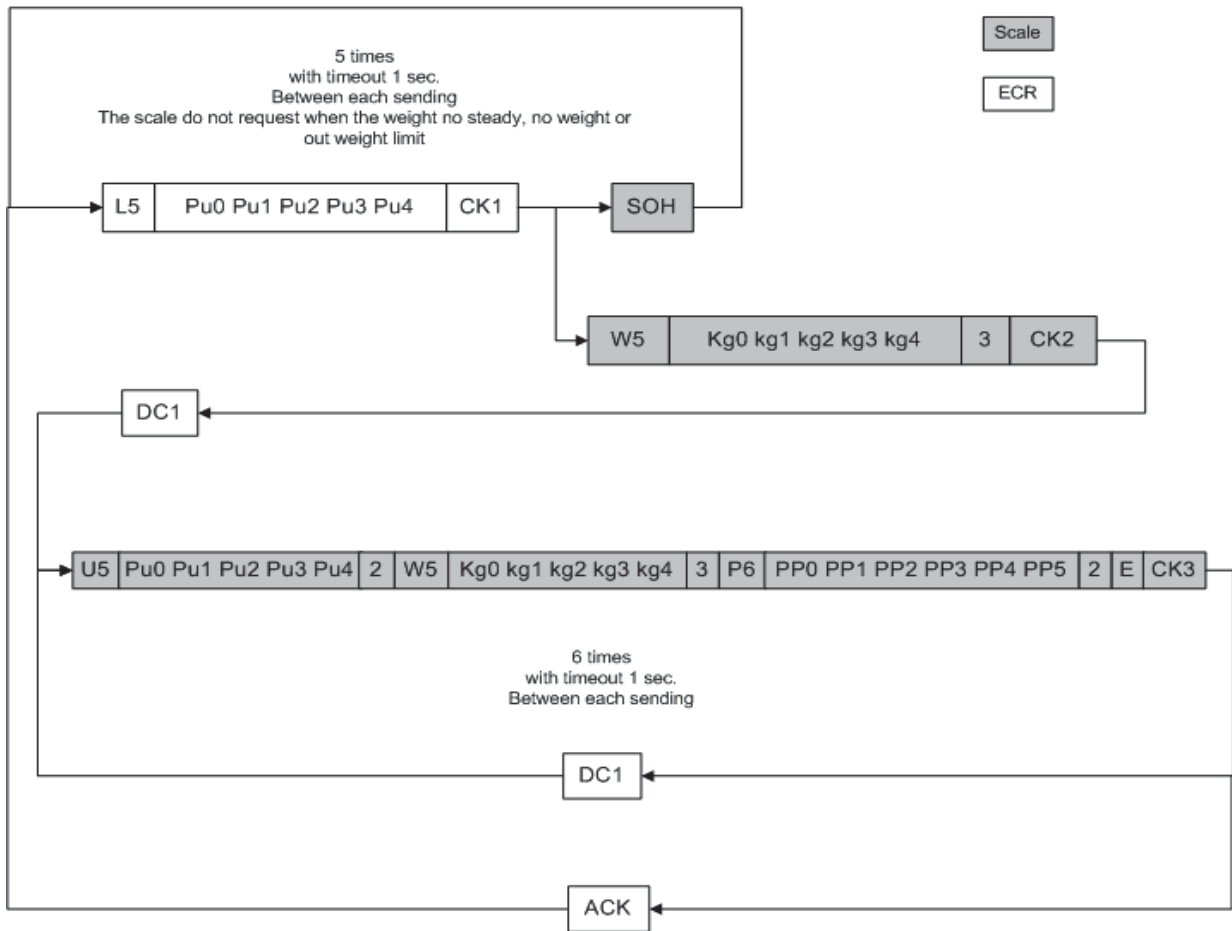

#### Checksum

CK1 = 91- (Pu0+Pu1+Pu2+Pu3+Pu4)

CK2 = 81-(kg0+kg1+kg2+kg3+kg4)

CK3 = 136-( somme Pu + somme kg + somme pp)

#### Codes

SOH = 01Hex.

DC1 = 11Hex.

ACK = 06Hex.

#### Examples :

The Ecr send unit price 4,58€  
L58540074

The scale request 3,250kg  
W505230371

The scale send the full message with unit price 16,43€, Weight = 1,430kg and Price to pay = 23,50€  
U5346102W5034103P60532002E104

**Note: Scale replies to L5 request with SOH if in motion, under zero, over capacity, can not capture zero, or if there is no weight available.**

### 6.1.6 Dialog 02 / 04

**Note:** To use Dialog 04, select this protocol but set the baud rate to 4800

#### 6.1.6.1 Data Format

Baud rate: 2400 Baud  
 Type of transmission: asynchronous  
 Data format: 7 Bit + Parity  
 Parity: odd  
 Stop bits: 1 Bit  
 Connection

<b>Scale</b>	<b>POS</b>
TXD 3	2 RXD
RXD 2	3 TXD
GND 5	5 GND

#### 6.1.6.2 Flow Chart

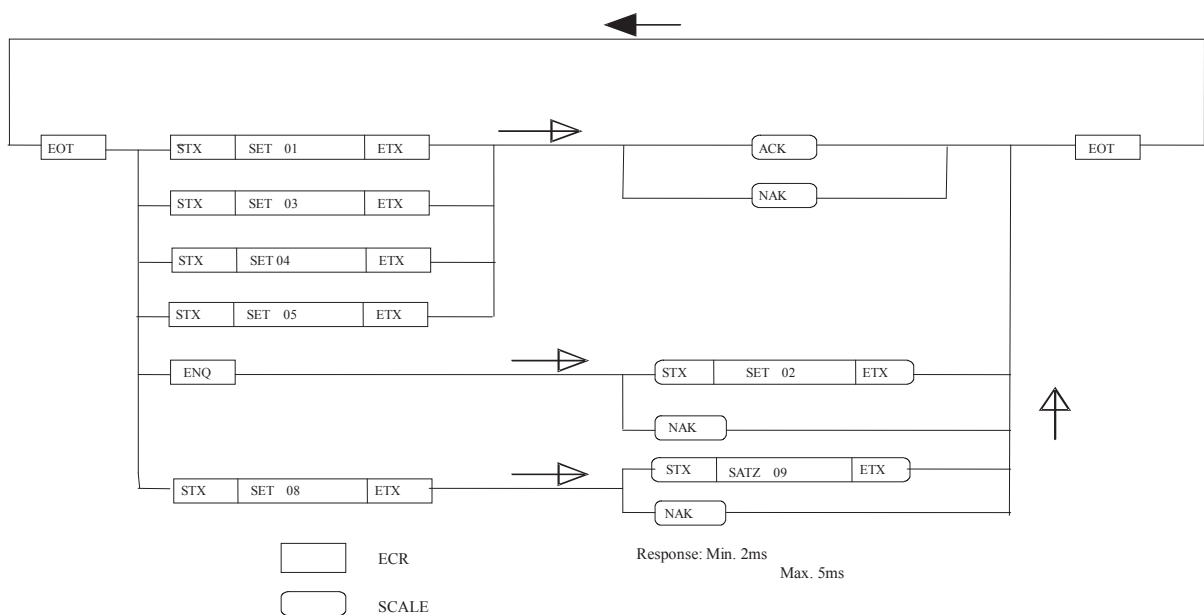

**Note:** The scale replies to ENQ with NAK when there is no load on the platter, the scale is in motion, under zero, or overcapacity. NAK is sent in response to the setting strings if there is invalid data in the setting.

#### 6.1.6.3 Command Descriptions

##### POS System Communications to a Scale

<b>Setting number 01 - Basic Price</b>																
EOT	STX	30h	31h	ESC	D5	D4	D3	D2	D1	D0	ESC	ETX				
		Setting number (01)			Basic Price 6 digits											
<b>Setting number 03: Basic Price, Tare Value</b>																
EOT	STX	03h	33h	ESC	D5	D4	D3	D2	D1	D0	ESC	T3	T2	T1	T0	ETX
		Setting number (03)			basic price 6 digits						tare value 4 digit					
<b>Setting number 04: Basic Price, Text</b>																
EOT	STX	30h	34h	ESC	D5	D4	D3	D2	D1	D0	ESC	A.....A				ETX

\ / Setting number (04)	\ / Basic price 6 digits	\ / text 13 chars	
<b>Setting number 05: Basic Price, Tare value, Text</b>			
EOT STX 30h 35h ESC	D5 D4 D3 D2 D1 D0	ESC T3 T2 T1 T0 ESC	A.....A ETX
\ / setting number (05)	\ / Basic price 6 digits	\ / tare value 4 digits	\ / text 13 chars
<b>Setting number 08: Status information Request</b>			
EOT STX 30h 38h ETX			
\ / Setting number (08)			
<b>Scale data reading</b>			
EOT ENQ			

### Scale Communications to a POS System

<b>Setting number 02: Weight, Price, and Total Price</b>										
STX 30h 32h ESC X ESC	D4 D3 D2 D1 D0	ESC	D5 D4 D3 D2 D1 D0	ESC	D5 D4 D3 D2 D1 D0	ETX				
\ / setting no. (02)	\ / scale - weight 5 digits	 status 30H = lb 31H = lb. / 0,01 32H = lb. / 0,005 33H = kg	\ / Basic price 6 digits	\ / Price to pay 6 digits						
<b>Setting number 09: Status information</b>										
STX 30h 39h ESC	S1 S0	ETX								
\ / setting no. (09)	\ / Status   Status: ASCII code 2 bytes 00 there is no error 01 general errors in the scale 02 parity error or more symbols that are permitted 10 invalid setting no. 11 invalid basic price 12 invalid tare value received 13 invalid text received 20 scale is still in motion (no standstill) 21 scale wasn't in motion since last operation 22 there is still no price calculation 30 weight is less than minimum weight 31 scale is less than 0 32 scale is overloaded									

## 6.1.7 NCI POS

### 6.1.7.1 OVERVIEW

The serial communications protocol is used to interface Weigh-Tronix/NCI POS (Point-of-Sale) scales to ECR (Electronic Cash Registers), or other computing equipment (eg. personal computers).

Baud rate and parity will be configurable. Start and stop bits will each be fixed at one (1). Data bits will be fixed at seven. Baud rates supported will be 1200, 2400, 4800, 9600 and 19200. Responses to serial commands will be immediate, or within one weight meter cycle of the scale. One second should be more than adequate for use as a time-out value by the remote (controlling) device.

There are two types of serial commands: *mandatory* and *optional*. Mandatory commands must be supported by all products.

If weight is negative, in motion, over capacity or under capacity, or if a zero error exists, only the scale's status is returned in response to a weight ('W') command.

Status bytes are prefaced by the letter 'S'.

Units of measure abbreviations are always upper case.

The weight is always positive. Therefore there is no polarity byte

Key to symbols used:

<ETX> End of Text character (03 hexadecimal).

<LF> Line Feed character (0A hex).

<CR> Carriage Return character (0D hex).

<SP> Space (20 hex).

x Weight characters from display including minus sign and out-of range characters.

hh Two status bytes.

UU Units of measure (LB, KG, OZ, G, etc., all upper case).

### Mandatory Commands

Name: Request weight

Command: W<CR>

Response: Returns decimal weight, units and status. (see note 1 and 2)  
<LF>xx.xxxUU<CR><LF>Shh<CR><ETX>

Return lb-oz weight with units PLUs scale status.

<LF>xLB<SP>xx.xOZ<CR><LF>Shh<CR><ETX>

Scale status only if wt < 0, initial zero error, in motion or out of capacity.

<LF>Shh<CR><ETX>

Name: Request status

Command: S<CR>

Response: Returns scale status.  
<LF>Shh<CR><ETX>

Name: Zero the scale

Command: Z<CR>

Response: Scale is zeroed, returns scale status. (See note 4)  
<LF>Shh<CR><ETX>

### Optional Commands

Name: Request high-resolution weight

Command: H<CR>

Response: Returns decimal wt in 10x with units plus scale status. (See notes 2 and 3)  
<LF>xxx.xxxUU<CR><LF>Shh<CR><ETX>

Return lb-oz wt in 10x with units PLUs scale status.

<LF>xLB<SP>xx.xxOZ<CR><LF>Shh<CR><ETX>

Scale status only if wt < 0, initial zero error, in motion or out of capacity.

<LF>Shh<CR><ETX>

Name: Change units of measure

Command: U<CR>

Response: Changes units of measure, returns new units and scale status.  
<LF>uu<CR><LF>Shh<CR><ETX>

Name: Request metrology raw counts

Command: M<CR>

Response: Returns normalized raw counts and scale status.

<LF>xxxxxxMM<CR><LF>Shh<CR><ETX>

Name: unrecognized command  
Command: all others  
Response: Unrecognized command  
<LF>?<CR><ETX>

**NOTES:**

- 1) Weight field is always six characters (5 for weight, 1 for decimal point), regardless of display size.
- 2) Leading zeroes are not suppressed.
- 3) High resolution weight field is seven characters (6 for weight, 1 for decimal point), regardless of display size.
- 4) If scale is outside zero range or in motion the 'Z' command is ignored and scale status is returned without zero status flag set, i.e., scale not at zero.

**Weight Command: W**

This command causes the scale to return the displayed weight string in ECR format. The scale will usually return the displayed weight with leading zeroes (ie no leading zero suppression).

However, if weight is negative, in motion, over capacity or under capacity, or if a zero error exists, the ECR protocol causes only the scale's status to be returned in response to a weight ('W') command.

The returned weight string will include decimal point plus units of measure. The length of the weight field will be equal to the length of the scale's display plus three (one for the decimal point, and two for the units, e.g., "LB"). For pounds-ounce weight, the length of the weight field will be equal to the length of the scale's display plus five (one for the decimal point, two for the "LB" and two for the "OZ"). Units of measure will appear in their ANSI standard abbreviated form ("LB" for pounds, "KG" for kilograms, etc.) in uppercase characters.

**Zero Command: Z**

If zeroing criteria are met, the scale is zeroed. In any case, scale status is returned.

**High-Resolution Command: H**

This is the same as the **W** command except that when weight is returned, it is returned with ten times the scale's display resolution.

**Change Units Command: U**

The effect of this command will be the same as if the *UNITS* key on the scale were pressed, causing the scale to change its units of measure. In response, the scale will return the new units of measure and scale status.

**Metro Command: M**

This command is optional. It will cause the scale to return normalized raw counts used for metrology verification. The count value is the same number displayed in the scale's division test in its diagnostics mode. For example, this number ranges up to 120,000 for the 67xx, 100,000 for the 78xx and 1,000,000 for QDT scales.

**Scale Status Command: S**

There will be at least two status bytes. If bit 6 of the second status byte is set then there will be a third byte. Bit 6 of each successive byte will indicate whether or not another status byte follows. The bit will be clear (0) in the last status byte. At this time only the first three bytes are defined. Others may be added in the future. Bit 0 is the least significant bit in the byte while bit 7 is the most significant bit.



The status bits are defined as follows:

Bit	Status Byte 1	Status Byte 2	Status Byte 3 (optional)	Status Byte 4 (optional)
0	1 = Scale in motion 0 = Stable	1 = Under capacity 0 = Not under capacity	00 = Low range 01 = (undefined) 10 = (undefined) 11 = High range	1 = Weight Change 0 = No Change
1	1 = Scale at zero 0 = Not at zero	1 = Over capacity 0 = Not over capacity		1 = Zero Detected 0 = No Zero Seen
2	1 = RAM error 0 = RAM okay	1 = ROM error 0 = Calibration okay	1 = Net weight 0 = Gross weight	1 = Metric 0 = English
3	1 = EEPROM error 0 = EEPROM okay	1 = Faulty calibration 0 = Calibration okay	Initial zero error	Unused
4	<b>Always 1</b>	<b>Always 1</b>	<b>Always 1</b>	<b>Always 1</b>
5	<b>Always 1</b>	<b>Always 1</b>	<b>Always 1</b>	<b>Always 1</b>
6	<b>Always 0</b>	1 = Byte follows 0 = Last byte	1 = Byte follows 0 = Last byte	1 = Byte follows 0 = Last byte
7	Parity	Parity	Parity	Parity

## 7. Appendix2

### 7.1 Connect between POS and RS232 port

#### 7.1.1 Set OP Setting

S15 = 0

S16 = 0

#### 7.1.2 Choose protocol

Set OP Setting S20 to select correct protocol.

#### 7.1.3 Connect

Connect scale and cash register with correct cable.

### 7.2 Connect between POS and USB port

#### 7.2.1 Set OP Setting

S15 = 1

S16 = 0

#### 7.2.2 Choose protocol

Set OP Setting S20 to select correct protocol.

#### 7.2.3 Install driver and Connect

Install the virtual COM driver. Please go back to your scale manufacturer to get the COM driver and install it.

Connect scale and cash register with correct cable.

**Note: COM driver need to be installed when USB connects with POS. If customers use RS232, no need to install it.**

OHAUS

P/N: 72246394

(10/2010) 1.0

OHAUS® is a Trademark of OHAUS, Inc.

Printed in China

\* 72246394\*