

C315

**1-LOAD-CELL PLATFORM SCALES
4-LOAD-CELL PLATFORM SCALES
PALLET AND BEAM SCALES**

USER MANUAL

ITKU-109-05-09-21-EN













RADWAG® RADWAG BALANCES AND SCALES
ADVANCED WEIGHING TECHNOLOGIES

SEPTEMBER 2021

PRECAUTIONS

Prior to installation, use or maintenance activities, carefully read this user manual and follow the provided guidelines.

	Prior to the first use, carefully read this user manual. Use the weighing device only as intended.
	Place weighed loads in the centre of the weighing pan.
	Load the weighing pan with loads of gross weight which does not exceed the maximum capacity.
	Mind not to leave heavy loads on the weighing pan for longer periods of time.
	Protect the indicator against considerable temperature variation, solar and UV radiation, substances causing chemical reactions.
	The weighing device must not be operated in hazardous areas endangered with explosion of gases, and in dusty environments.
	In case of damage, immediately unplug the device from the mains.
	Scales to be decommissioned must be decommissioned in accordance with valid legal regulations.
	Do not let battery discharge in case of prolonged storage of the device in low temperature.
	Accumulators do not belong to regular household waste. The European legislation requires discharged accumulators to be collected and disposed separately from other communal waste with the aim of being recycled. Symbols on batteries identify harmful compounds: Pb = lead, Cd = cadmium, Hg = mercury. Dear user, you are obliged to dispose of the worn out batteries as regulated.
	If the scale is to be operated in conditions that are difficult due to electrostatics (e.g. printing house, packing centre, etc.), you must connect it to the earth wire. To enable this, the device features functional earthing terminal, marked with \perp symbol.

CONTENTS

1. INTENDED USE	5
2. WARRANTY CONDITIONS	5
3. MAINTENANCE ACTIVITIES	5
3.1. Cleaning ABS Components	6
3.2. Cleaning Stainless Steel Components	6
4. SERVICE AND REPAIR	6
5. RECYCLING	7
6. MECHANICAL DESIGN	7
6.1. 1-Load-Cell Scales	7
6.2. Multiple Load Cell Scales	8
6.3. Scales with Load-Cell Modules	8
6.4. Dimensions	9
6.5. Connectors Arrangement	9
6.6. Pins Arrangement	10
6.7. Operation panel	10
7. SCALE INSTALLATION	11
7.1. Unpacking and Installation	11
7.1.1. C315.xx.K, C315.xx.R, C315.F1.M Series	11
7.1.2. C315.C2.M, C315.C3.M Series	11
7.1.3. C315.4 Series	12
7.2. Levelling	13
7.2.1. Levelling: 1-Load-Cell Platform Scales	13
7.2.2. Levelling: 4-Load-Cell Platform Scales	13
7.3. Start-Up	14
7.4. Battery Status	14
7.5. Battery Charge Status Check	14
8. OPERATING THE MENU	15
8.1. Return to Weighing	15
9. WEIGHING	16
9.1. Good Weighing Practice: 4-Load-Cell Platform Scales	16
10. DIAGRAMS OF CONNECTION CABLES	17
11. TECHNICAL SPECIFICATIONS	18
12. TROUBLESHOOTING	18
13. ERROR MESSAGES	19

1. INTENDED USE

C315 series scales enable fast and accurate mass measurement in laboratory and industry. They feature plastic housing and backlit LCD. The devices are equipped with an internal battery which allows their operation in places where there is no access to the mains. Standard C315 scales feature RS232 interface for communication with external devices (printer, computer, etc.).

2. WARRANTY CONDITIONS

- A. RADWAG feels obliged to repair or exchange all elements that appear to be faulty by production or by construction.
- B. Defining defects of unclear origin and means of their elimination can only be realized with assistance of manufacturer and user representatives.
- C. RADWAG does not bear any responsibility for damage or losses resulting from unauthorized or inadequate performing of production or service processes.
- D. The warranty does not cover:
 - mechanical damage caused by product exploitation other than intended, damage of thermal and chemical origin, damage caused by lightning, overvoltage in the power network or other random event,
 - inappropriate cleaning habits.
- E. Loss of warranty takes place if:
 - a repair is carried out outside RADWAG authorized service point,
 - service claims intrusion into mechanical or electronic construction by unauthorized people,
 - the scale does not bear security stickers.
- F. Warranty conditions outline the warranty period for rechargeable batteries attached to the device for 12 months.
- G. For detailed warranty conditions read the warranty certificate.
- H. Contact with the central authorized service: +48 (48) 386 63 30.

3. MAINTENANCE ACTIVITIES

In order to ensure safety in the course of cleaning, it is necessary to disconnect the device from the mains. With this condition met, uninstall the weighing pan and other detachable components.



Cleaning the weighing pan while still installed may cause damage of the measuring system.

3.1. Cleaning ABS Components

To clean dry surfaces and avoid smudging, use clean non-colouring cloths made of cellulose or cotton. You can use a solution of water and detergent (soap, dishwashing detergent, glass cleaner). Gently rub the cleaned surface and let it dry. Repeat cleaning process if needed.

In the case of hard to remove contamination, e.g. residues of adhesive, rubber, resin, polyurethane foam etc., you can use a special cleaning agents based on a mixture of aliphatic hydrocarbons that do not dissolve plastics. Before using the cleanser for all surfaces we recommend carrying out tests. Do not use cleansers containing abrasive substances.

3.2. Cleaning Stainless Steel Components

Avoid using cleansers containing any corrosive chemicals, e.g. bleach (including chlorine). Do not use cleansers containing abrasive substances. Always remove the dirt using microfiber cloth to avoid damage of protective coating.

In case of a daily maintenance:

1. Remove the dirt using cloth dipped in warm water.
2. For best results, add a little bit of dishwashing detergent.

4. SERVICE AND REPAIR



In case of any sign of damage, it is necessary to disconnect the device from the mains immediately. The damaged component must be replaced or repaired by RADWAG service immediately.

In case of any problems with correct operation of the scale, contact the closest manufacturer's service point.

In case of defects, deliver the faulty product to the manufacturer's service point. If the product cannot be delivered to the manufacturer's service point, call the service and report the defect. Repair scope and method will be set up.



The user is NOT ALLOWED to carry out any kind of repair of the device himself/herself. Any attempt of scale modification, repair etc., by unauthorized persons, will result with loss of validity of manufacturer-issued certificates, declarations and warranty.

5. RECYCLING

C315 scales must be recycled, they are not to be treated as a regular household waste. Scales to be decommissioned must be decommissioned in accordance with valid legal regulations.



6. MECHANICAL DESIGN

6.1. 1-Load-Cell Scales

1-load-cell scale C315 is intended to carry out fast and precise mass measurement of up to 300 kg loads. Its characteristic feature is a platform with one load cell only. The platform is equipped with a stainless steel weighing pan. Depending on a scale model, the cross and base are made of either stainless steel or powder-coated steel.

1-load-cell scale design, the main components:

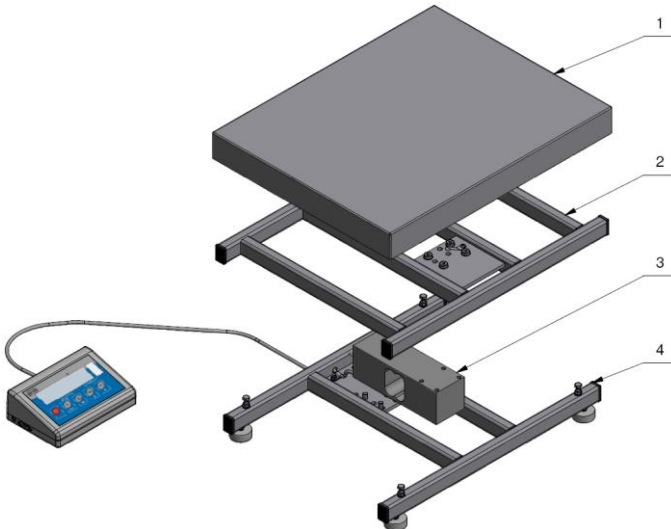

*1-load-cell scale design, the main components:
1 – weighing pan, 2 – cross, 3 - load cell, 4 - base.*

6.2. Multiple Load Cell Scales

Multiple load cell scale C315 is intended to carry out fast and precise mass measurement of large loads. Its characteristic feature is a platform equipped with numerous load cells, usually four. The platform, depending on a scale model, is made of stainless steel or powder-coated steel, it features customized mechanical design suiting particular customer's requirements (pallet, beam, platform scales).

Multiple load cell scale design, the main components:

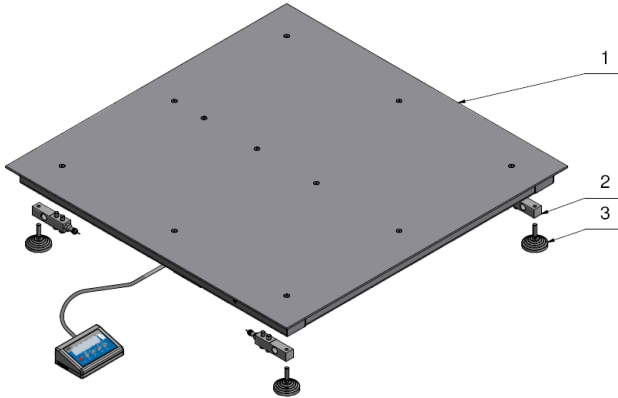

*Multiple load cell scale design, the main components:
1 - weighing pan, 2 - load cells, 3 - feet.*

6.3. Scales with Load-Cell Modules

C315 scale with load cell modules is intended to carry out mass measurement of silos. Modules are built into construction of ground-fixed silo's support. In most cases, the scale includes 3-4 load cell modules. The modules, depending on the model, are made of stainless or galvanized steel.

Scale design, the main components:

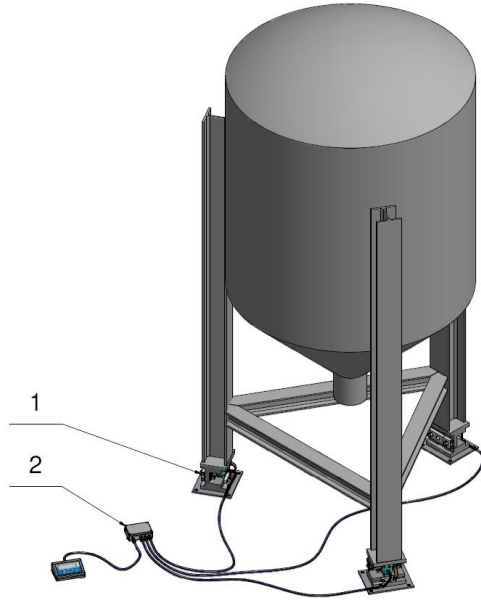

Scale design, the main components: 1 - module, 2 - junction box.

6.4. Dimensions



For overall dimensions, read product card of a respective scale, the product cards are to be found on RADWAG website www.radwag.com.

6.5. Connectors Arrangement

<p>1 – power supply socket 2 – RS232 (1) connector</p>	<p>3 – weighing platform cable inlet 4 – RS232 (2) connector *</p>

*) – option.



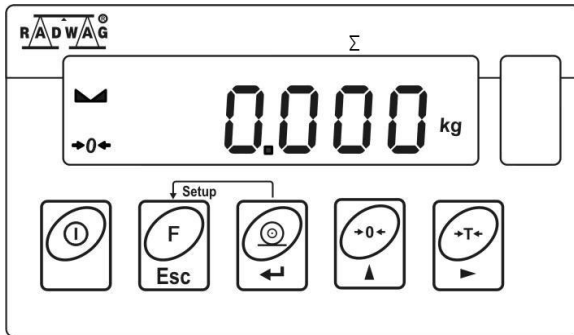

6.6. Pins Arrangement

	<p>Pin2 – RxD Pin3 – TxD Pin4 – 5VDC Pin5 – GND</p>	<p>RS232 (1) connector DB9/M (male)</p>
	<p>Pin2 – RxD Pin3 – TxD Pin4 – 5VDC Pin5 – GND</p>	<p>RS232 (2) connector DB9/M (male)</p>



6.7. Operation panel



Keys:

	<p>Press to switch the weighing device on/off – keep the key pressed for about 1 second.</p>
	<p>Function key, press to change the working mode.</p>
	<p>Press to send the weighing result to a printer or a computer.</p>
	<p>Press to zero the scale.</p>
	<p>Press to tare the scale.</p>



Upon pressing  +  keys combination, functions of given keys change. Detailed information concerning use of the above keys combination is to be found further down this manual.

7. SCALE INSTALLATION

7.1. Unpacking and Installation



Mind not to damage cable connecting the indicator and a weighing platform.

7.1.1. C315.xx.K, C315.xx.R, C315.F1.M Series

- Take the device out of the packaging.
- Place the device on a flat and even surface. Keep it far away from any sources of heat.
- Remove transport locks and install the weighing pan:

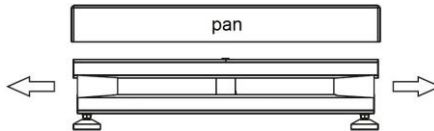

7.1.2. C315.C2.M, C315.C3.M Series

- Take the device out of the packaging.
- Place the device on a flat and even surface. Keep it far away from any sources of heat.
- Remove transport locks and install the weighing pan:

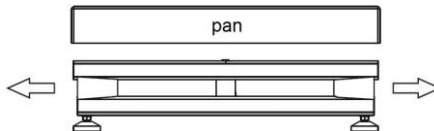

D. Fix the post to the scale, next fix the indicator to the post:

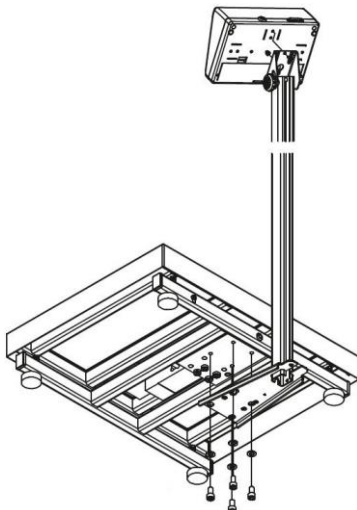

E. Lead the cable (in excess) into the post, next fix the support foot under the post:

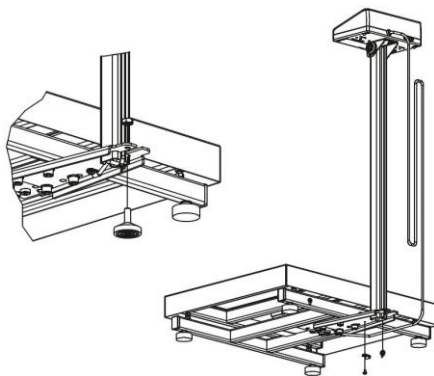

7.1.3. C315.4 Series

- A. Take the device out of the packaging (pallet).
- B. Place the device on a flat and even surface. Keep it far away from any sources of heat.
- C. Remove transport locks (if installed):



D. Fix the feet (if not installed):

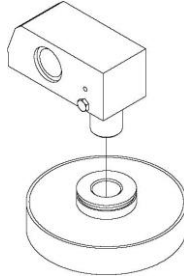

7.2. Levelling

7.2.1. Levelling: 1-Load-Cell Platform Scales

To level the weighing instrument turn its feet. Keep turning the feet until the air bubble takes central position:

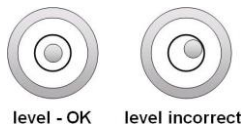

7.2.2. Levelling: 4-Load-Cell Platform Scales

To level the platform use the levelling feet and the level indicator. Each foot can be turned left and right, turning causes tilt. Adjustment span of the scale level is narrow therefore the correct level is obtained using steel washers which are to be put under the feet.

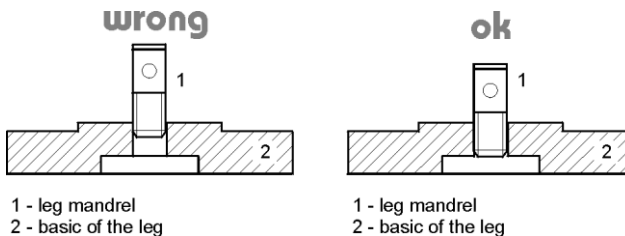

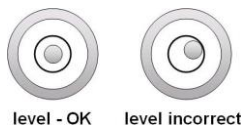

Keep turning the feet until the air bubble takes central position:



7.3. Start-Up

The weighing device can be connected to the mains only with a power supply that comes standard with the particular model. Nominal voltage of the power supply (specified on the power supply data plate) has to be compatible with the mains nominal voltage.

Procedure:



- Connect the power supply to the mains. Plug it to the power supply socket (back side of the scale housing).
- Press  key. The key is also used to switch the scale on/off.
- Display test proceeds (all symbols are backlit for a moment), program name and number is displayed first, ZERO indication with reading unit next (displayed reading unit is conditioned by scale type).
- In case the weighing result is not zero after indication stabilisation, press  button.

7.4. Battery Status

The scale of standard design is equipped with an internal battery. Battery state is signalled by  pictogram, the pictogram is displayed in the top bar of the display.

 pictogram display mode	Meaning
No pictogram	Battery charged. Regular scale operation.
Pictogram displayed continuously	Too low battery charge (the scale is about to shut down). Charge the battery immediately.
Blinking pictogram, blink frequency: ca. 1 s	Battery charge in progress. The device is connected to the power supply charging the battery.
Blinking pictogram, blink frequency: ca. 0.5 s	Battery error. Battery damaged.

7.5. Battery Charge Status Check













- Press  and  keys combination.
- Depending on the battery state, a respective status is displayed on the screen for 2s:

80%	Battery power supply. Battery power given in %.
CHARGE	Battery charge in progress. The device is connected to the power supply charging the battery.
-Err5-	Battery error. Battery is damaged.

- Next, the home screen is displayed automatically.

8. OPERATING THE MENU

In order to navigate the menu use the operation panel.

 + 	Press to enter the main menu.
 + 	Press to enter tare manually. Press to enter tare from tare database. Press to change value by 1 digit up. Press to scroll the menu up.
 + 	Press to check battery/accumulator state.
 + 	Press to view date/time.
	Press to scroll the menu down. Press to change current parameter value.
	Press to enter given submenu. Press to modify given parameter.
	Press to confirm modification.
	Press to exit, function remains unmodified. Press to move one menu level up.

8.1. Return to Weighing

Introduced modifications are automatically recorded upon return to the home screen. To return to the home screen press  key repeatedly.

9. WEIGHING

Load the weighing pan. Read the result when  stability marker is displayed. To assure long-term operation and correct mass measurements, follow the rules presented below:

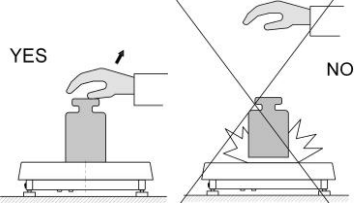
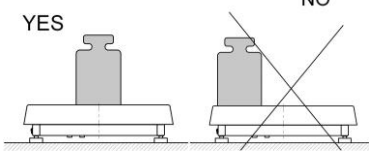
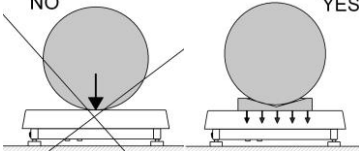
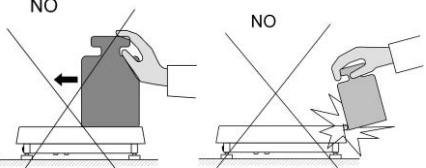
<p>Avoid applying mechanical shocks to the weighing pan.</p>	
<p>Place the loads centrally on the weighing pan (eccentricity errors are specified by PN-EN 45501 standard, point 3.6.2).</p>	
<p>Do not apply concentrated force (total load in one point).</p>	
<p>Avoid side loading, in particular side shocks.</p>	

9.1. Good Weighing Practice: 4-Load-Cell Platform Scales

It is forbidden to apply load other than intended for a particular scale:

- beam scales; self-supporting, rigid load or load placed in rigid load-transferring packaging:

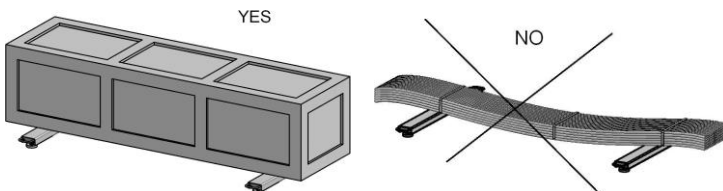

11. TECHNICAL SPECIFICATIONS

For technical specifications of respective scales go to RADWAG website www.radwag.pl.

12. TROUBLESHOOTING

Problem	Cause	Solution
Scale start-up fail.	Power supply disconnected.	Connect the power supply to the scale.
	Battery discharged.	Connect the power supply to the mains, charge the battery.
	No battery (not installed or installed incorrectly).	Check if the battery is installed correctly (polarization).
The scale switches off automatically.	<7.4.t1> parameter set to value enforcing scale shut-down after particular time interval.	Go to <P7.Othr> menu, set <7.4.t1> parameter to 'nonE' value.
During the start-up, message 'LH' is displayed.	Weighing pan loaded during the start-up.	Unload the weighing pan. Zero indication is displayed.
Communication with the computer not established.	Incorrect computer port set in parameter <5.1.1.Prt>.	Enter < P5.ducE / 5.1.PC> submenu and set correct <5.1.1.Prt> parameter value.
	Incorrect transmission parameters for the selected computer port.	Enter <P4.Conn> menu and set correct transmission parameters for the selected computer port.
	Incorrect printout frequency for continuous transmission.	Enter < P5.ducE / 5.1.PC> submenu and set correct <5.1.3.Int> parameter value.
No printout on a scale-connected printer.	Incorrect printer port set in <5.2.1.Prt> parameter.	Enter < P5.ducE / 5.2.Prtr> submenu and set correct <5.2.1.Prt> parameter value.
	Incorrect transmission parameters for the selected printer port.	Enter <P4.Conn> menu and set correct transmission parameters for the selected printer port.
	No variable declared in weighing printout project.	Enter <P6.Prnt / 6.2.GLP> submenu and declare variables that are to be printed.
Communication with the additional display not established..	Incorrect additional display port set in <5.3.1.Prt> parameter.	Enter < P5.ducE / 5.3.AdSP> submenu and set correct <5.3.1.Prt> parameter value.
	Incorrect transmission parameters for the selected computer port.	Enter <P4.Conn> menu and set correct transmission parameters for the selected additional display port.
Displayed mass unit does not comply with the scale data plate.	Changed scale start unit in <9.1.UnSt> parameter.	Enter <P9.Unit / 9.1.UnSt> submenu and set unit complying with the scale data plate.
	Changed custom unit in <9.2.Unin> parameter.	Enter <P9.Unit / 9.2.Unin> submenu and set unit complying with the scale data plate.

13. ERROR MESSAGES

- Err 2 -	Value beyond zero range.
- Err 3 -	Value beyond tare range.
- Err 4 -	Adjustment weight or start mass out of range ($\pm 1\%$ for adjustment weight, ± 10 for start mass).
- Err 5 -	Battery error. Battery is damaged.
- Err 8 -	Time of the following operations exceeded: taring, zeroing, start mass determining, adjustment process.
- null -	Zero value from converter.
- FULL -	Weighing range exceeded.
- LH -	Start mass error, indication out of range ($\pm 10\%$ of start mass).
- Hi -	Display range of total mass on scale display exceeded in 'Totalizing' mode.
- Err Lo -	<ul style="list-style-type: none"> - Determined mass of single part in 'Parts counting' mode too small. - Value of 'Min' threshold is greater than value of 'Max' threshold in '+/- control' mode.
- Err Hi -	<ul style="list-style-type: none"> - Entered value of single part greater than maximum capacity in 'Parts counting' working mode. - Entered value of 'Max' threshold greater than maximum capacity in '+/- control' mode. - Entered reference mass greater than maximum capacity in 'Percent weighing' mode.



RADWAG BALANCES AND SCALES
ADVANCED WEIGHING TECHNOLOGIES

